

SECTION No. 2

Association of American Railroads
OPERATIONS AND
MAINTENANCE DEPARTMENT
MECHANICAL DIVISION

RULES GOVERNING
THE
Loading of Steel Products
Including Pipe
On Open Top Cars

Adopted by the
Former Master Car Builders' Association
as Recommended Practice, 1896
Advanced to Standard 1908

EFFECTIVE FEBRUARY 1, 1960

Published by the Association of American Railroads
59 East Van Buren Street, Chicago 5, Illinois

1960

Printed in U. S. A.



SECTION No. 2

PART 1

RULES GOVERNING

THE

Loading of Steel Products
On Open Top Cars

NOTICE

See General Rules—Section No. 1 for the following:

Preface.

Attention Shippers.

Index.

General Rules.

Instructions—Experimental Loads.

Dictionary of Car and Loading Terms.

Table Nos. 1 to 35, inclusive

Where reference is made in the specifications of any of the figures in these rules to Fig. Nos. 1-B, 2, 3, 4, 5, 5-A or 5-B, see General Rules—Section No. 1.

The construction shown in figure Nos. 26, 27 and 69, Part No. 1, also Fig. No. 147, Part No. 2, are patented.

Sec. 2—Fig. 1

BEAM STEEL FLOORING—FLAT CARS

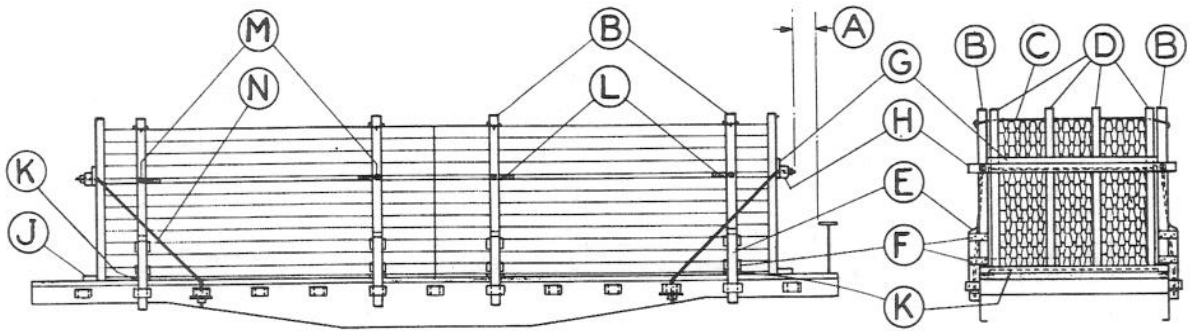

Item	No. of Pcs.	Description
A		Brake wheel clearance. See Fig. 2.
B	Pile 20 ft. long or less, 2 pr. Add 1 additional pr. for each 10 ft., or less, over 20 ft.	Stakes, hardwood, extending above load to permit application of Item "C".
C	1 ea. pr. Items "B"	6 strands, No. 11 ga. wire.
D	4 ea. end of load	4 in. x 4 in., hardwood.
E	4 per pile	4 in. x 5 in., hardwood, extending 24 in. above floor.
F	4 ea. Item "B"	1 in. x 4 in., hardwood, length to suit, nailed to Items "B" and "E" with three 10-D nails in each end.
G	1 ea. end of load	1½ in. x 6 in., hardwood, located about 2/3 height of pile. Nail to each Item "D" with three 20-D nails.
H	1 ea. end of load	4 in. x 4 in., hardwood, place on top of Item "G". Nail to Item "D" with 60-D nails.
J	1 ea. end of load	1½ in. x 6 in., hardwood, length equal to width of car, nailed to floor with 30-D nails.
K	1 ea. pr. Items "B"	1½ in. x 6 in., hardwood, length equal to width of car between stakes, nailed to floor with 10-D nails.
L	1 ea. pr. Items "B"	1½ in. x 4 in., hardwood, length equal to width of load. Located 2/3 height of pile. Not required when load is less than 42 in. high.
M	1 ea. pr. Items "B"	½ in. dia., with washers.
N	2 ea. end of load	½ in. dia., with washer, ½ in. x 4 in. x 10 in. plate under stake pocket.

See General Rules, 4, 5, 7, 9, 10, 14 and 15 for further details.

BEAM STEEL FLOORING WITH HIGH TENSION BANDS—FLAT OR GONDOLA CARS

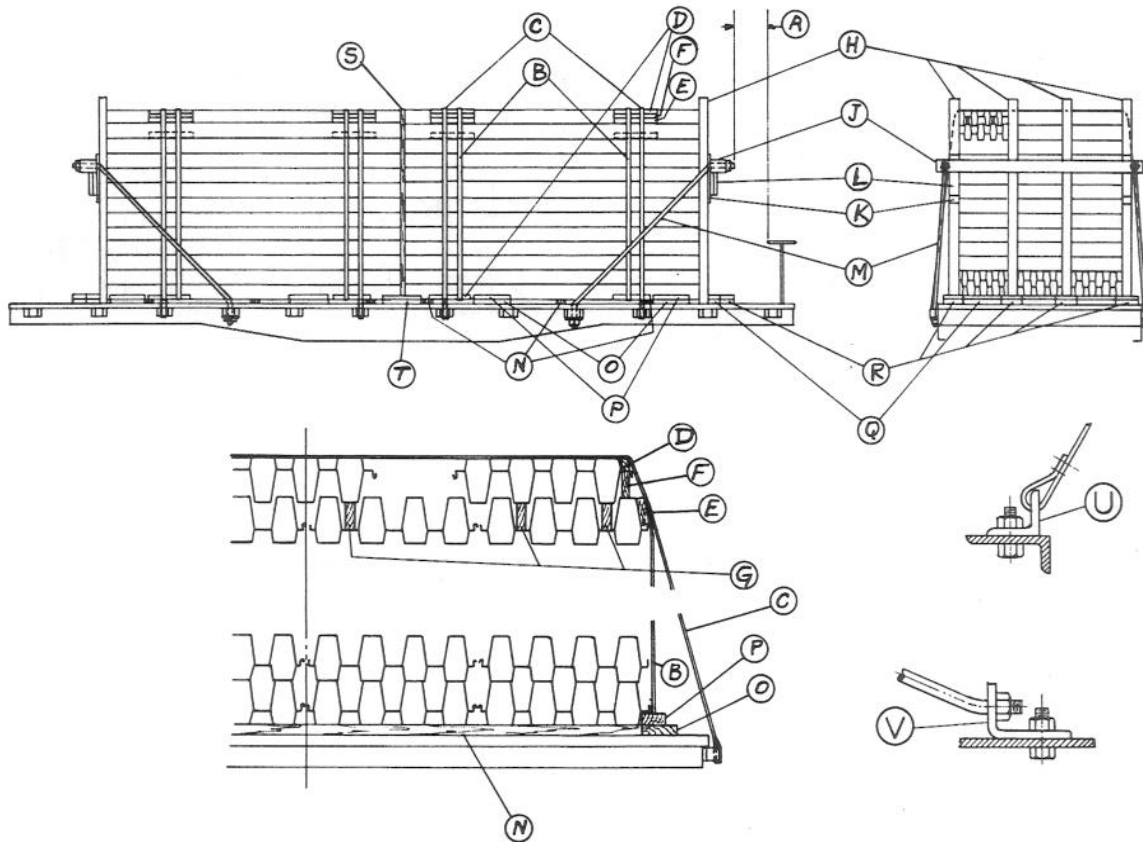

Item	No. of Pcs.	Description
A		Brake wheel clearance. See Fig. 2.
B	Pile 20 ft. long or less, 2. Add 1 additional for each 10 ft. or less, over 20 ft. long.	1 1/4 in. x .035 in. bands.
C	Pile 20 ft. long or less 2. Add 1 additional for each 10 ft., or less, over 20 ft. long	1 1/4 in. x .035 in. bands. Secure to stake pockets of flat cars, or top side chords of gondola cars.
D	4 ea. Item "B"	1 1/2 in. x 1 1/2 in. x 24 in., hardwood, underneath Items "B" and "C".
E	2 ea. item "B"	2 in. x 4 in. x 24 in., hardwood, underneath Items "B" and "C".
F	2 ea. Item "B"	1 1/2 in. x 1 1/2 in. x 24 in., hardwood, underneath Items "B" and "C".
G	As required	2 in. x 3 in. x 24 in., hardwood.
H	4 ea. end of load	4 in. x 5 in., hardwood, length to suit, toe-nailed to floor.
J	1 ea. end of load	5 in. x 8 in., hardwood, length to suit. Use one bolt, 1/2 in. dia., crosswise, with washers, at end to prevent splitting.
K	1 ea. Item "H"	1 in. x 4 in. x 24 in., hardwood. Nail to Items "H".
L	4 ea. end of load	1 1/2 in. x 4 in. x 12 in., hardwood. Nail to Items "H", "K", and each other.
M	2 ea. end of load	1/2 in. dia. with washer at Item "J". Pass through Item "J" and 1/2 in. x 4 in. x 10 in. plate under stake pocket on flat cars or Items "V" in gondola cars.
N	3 per pile	1 1/2 in. x 4 in., hardwood, length equal to width of load.
O	4 per pile	1 1/2 in. x 6 in. x 20 in., hardwood. Nail to floor.
P	4 per pile	1 1/2 in. x 4 in. x 20 in., hardwood. Nail to Items "O."
Q	2 ea. end of load	1 1/2 in. x 6 in., hardwood, length equal to width of load. Nail to floor against Items "H".
R	2 ea. Item "H"	1 1/2 in. x 6 in. x 12 in., hardwood. Nail to Items "Q".
S	5 between piles	1/2 in. x 6 in., hardwood, length equal to height of pile, secured to prevent displacement.
T	As required.	Same as Items "O" and "P". Nail to floor and to each other.
U	2 ea. Item "C"	1/4 in. x 2 in. x 3 in. x 4 in. angle. Secure to top chord angle with one 5/8 in. dia. bolt. Use suitable filler to protect band.
V	1 ea. Item "M"	3/4 in. x 2 in., length to suit. Secure to top chord angle with one 5/8 in. dia. bolt.

See General Rules 4, 5, 9, 10, 14 and 15 for further details.

Sec. 2—Fig. 3

BEAM STEEL FLOORING, WITH HIGH TENSION BANDS—FLAT OR GONDOLA CARS

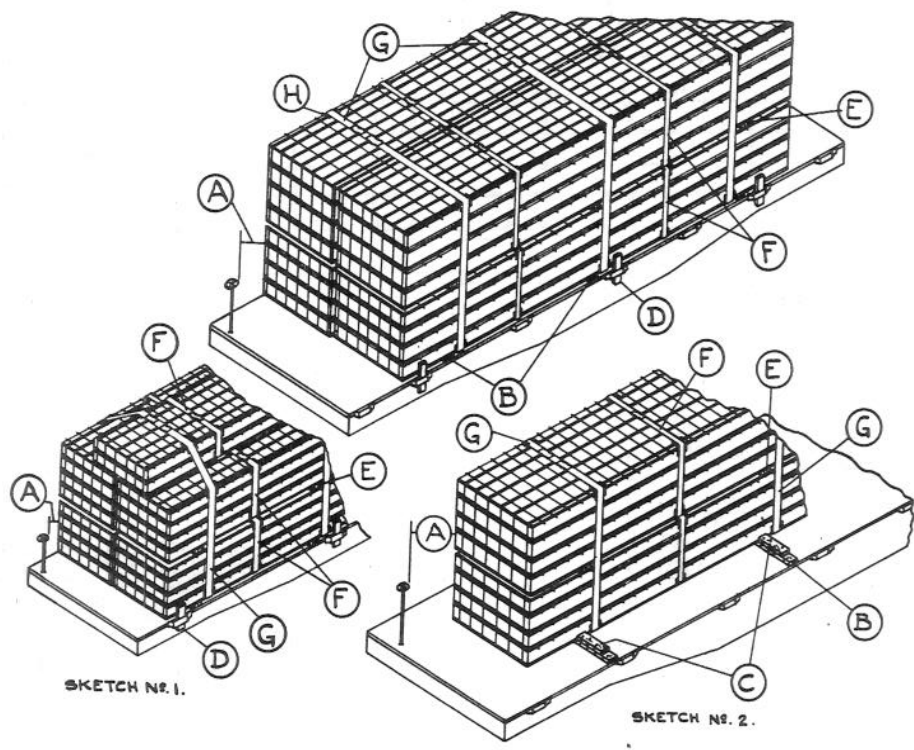

Item	No. of Pcs.	Description
A		Brake wheel clearance. See Fig. 2.
B	As required.	1½ in. x 4 in., hardwood, length equal to width of car. Locate about 3 ft. from each end of pile, with intermediate pieces not more than 12 ft. apart.
C	2 ea. Item "B"	2 in. x 4 in. x 12 in., hardwood. Place on top of Items "B" with one end against load, and secure with 40-D nails. Not required when load equals width of car, nor for gondola cars when total vacant space between pile and car sides does not exceed 18 in.
D	3 pr. per pile	Stakes, high enough to prevent load from shifting beyond car sides, but must not contact cross bars of bottom section. Not required when Items "C" are used.
E	As required	2 in. x 4 in., length equal to width of load. Locate about 2 ft. from each end of pile, with intermediate pieces not more than 12 ft. apart. Use optional.
F	2	1¼ in. x .035 in. bands. Place 2 bands around each bundle consisting of 2 and not more than 4 sections, and locate ⅓ the length of pile from each end.
G	Pile 30 ft. long or less, 3. Add 1 band for ea. additional 10 ft. or less in length.	2 in. x .050 in. bands, around entire load. Place outer bands about 2 ft. from each end of pile, with intermediate bands equally spaced.
H	As required.	Protection angles, 20 gage, 4 in. wide, applied so as to prevent displacement.

When load consists of two piles, loaded side by side, place left over sections on top of load, at center, as shown in Sketch 1.

See General Rules 4, 5, 9, 10, 14 and 15 for further details.

Sec. 2—Fig. 4

BEAM STEEL FLOORING, WITH HIGH TENSION BANDS—GONDOLA CARS

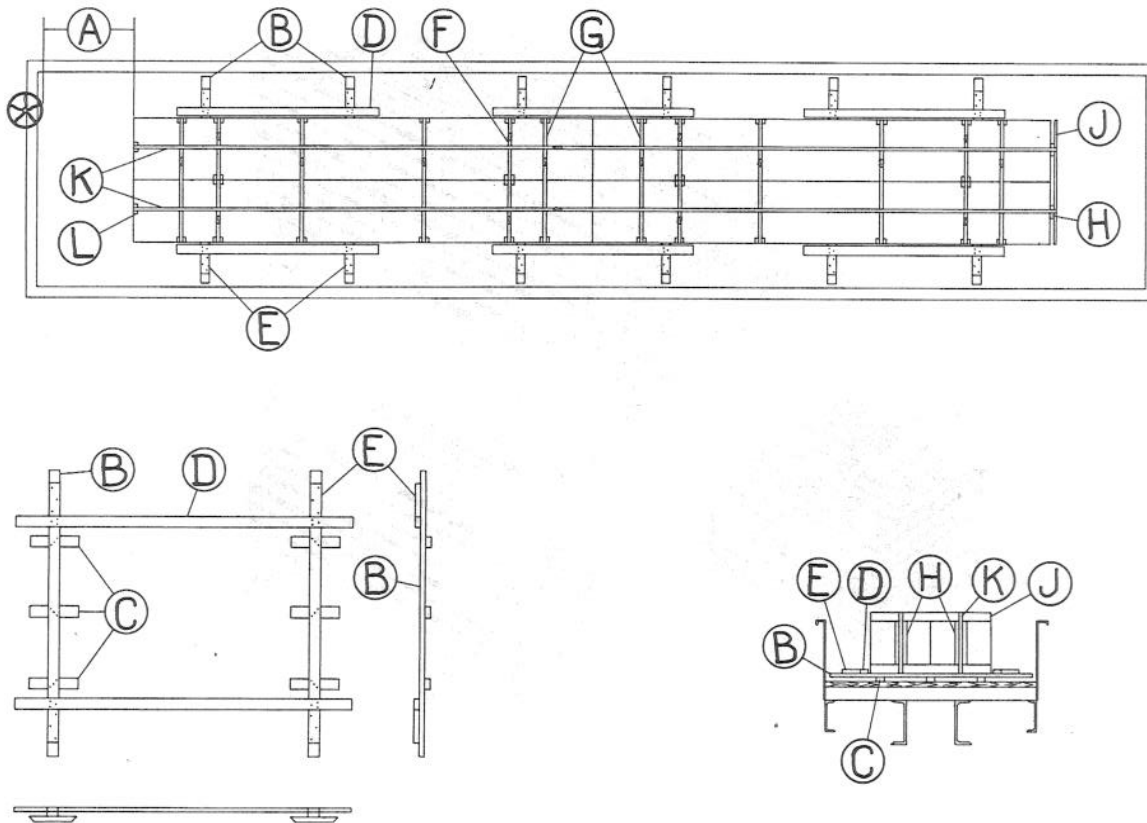

Item	No. of Pcs.	Description
A		Brake wheel clearance. See Fig. 2.
B	As required	2 in. x 4 in., hardwood, length 2 in. less than width of car. Locate about 3 ft. from each end of each pile with intermediate pieces not more than 12 ft. apart.
C	3 ea. Item "B".	2 in. x 4 in. x 18 in., hardwood, bevel at ends. Locate, as shown, suitably spaced under Item "B" and nail each to Item "B" with three 20-D nails.
D	As required.	2 in. x 4 in., hardwood, long enough to extend 4 in. beyond Items "B". Locate about 1 in. from pile and secure to each Item "B" with three 20-D nails.
E	2 ea. Item "B".	2 in. x 4 in. x 12 in., hardwood. Locate on top of Items "B" with one end against Item "D" and nail each with three 20-D nails.
F	2	1¼ in. x .035 in. high tension bands. Place two bands around each lift consisting of two and not more than four sections, and locate about ½ the length of pile from each end.
G	4 ea. pile.	2 in. x .050 in. high tension bands, encircling entire pile. Locate outer bands about 2 ft. from ends of pile and intermediate bands suitably spaced.
H	2	2 in. x 6 in., hardwood, length equal to height of pile. Locate, as shown, about 1 ft. from each side against end of pile at the open end floor section only.
J	2	1 in. x 4 in., hardwood, length about equal to width of pile. Locate at top and bottom of Items—"H" and nail each to Items "H" with four 10-D nails.
K	2	2 in. x .050 in. high tension bands, lengthwise, around entire load and Items "J", as shown.
L	As required.	Protection angles, 20 gage, 4 in. wide, applied to as to prevent displacement.

See General Rules 4, 5, 9, 14 and 15 for further details.

BEAM STEEL FLOORING, 9 FT. HIGH OR LESS ABOVE FLOOR—GONDOLA CARS

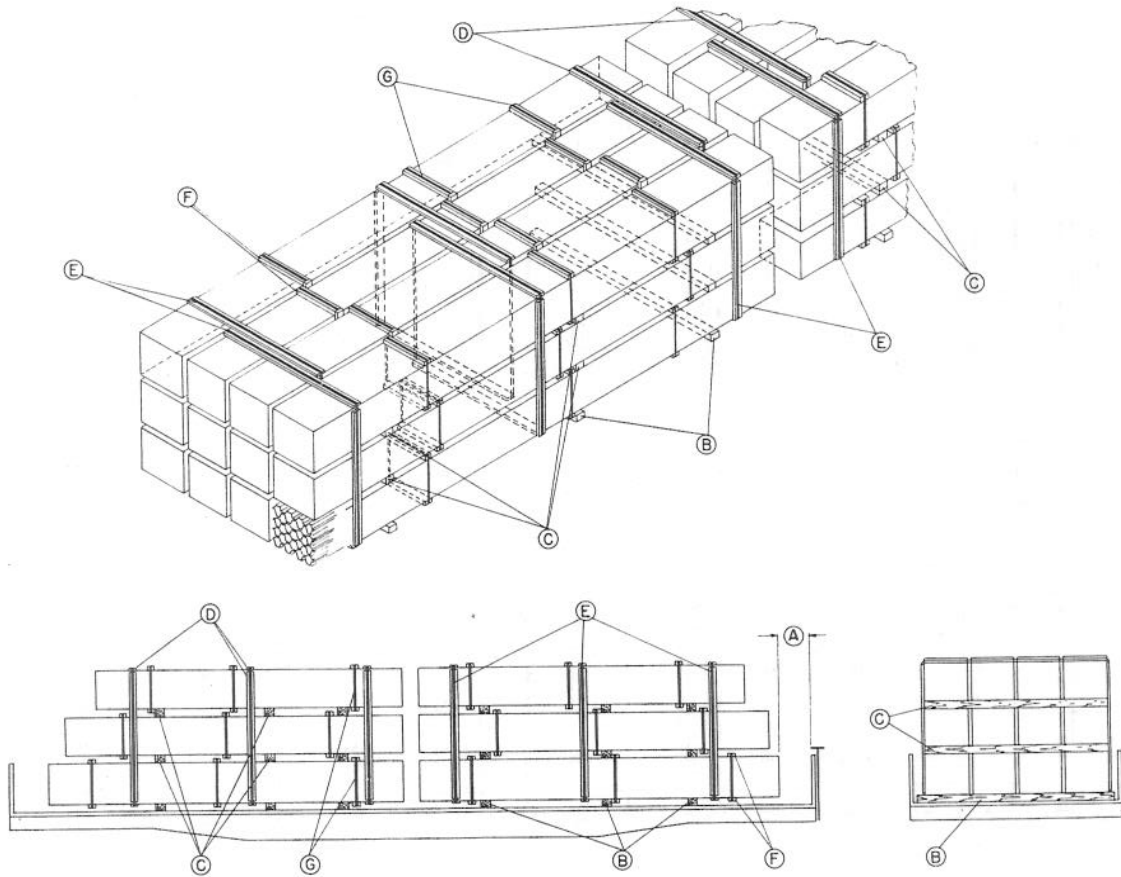

Item	No. of Pcs.	Description
A		Brake wheel clearance. See Fig. 2.
B	3 per pile.	Bearing pieces, 3 in. x 4 in., length 2 in. less than width of car. Locate about 3 ft. from each end of pile with intermediate bearing piece at about center.
C	3 per layer.	Separators, 3 in. x 4 in., length width of pile. Locate directly above Items "B".
D	As required.	1 in. x 6 in., length to suit, between Items "E" and lading, on sides, bottom and top.
E	6 per pile.	2 in. x .050 in. high tension bands as chain ties, 3 on each side of pile encircling 2 or 3 rows. Locate not less than 1 ft. from Items "B" and staple to Items "D".
F	As required.	2 in. x 4 in., length width of package. Locate between Items "G" and lading.
G	2 per package 15 ft. or less. Add 1 additional over 15 ft. long.	1 1/4 in. x .035 in. high tension package bands. Locate 1 band about 2 ft. from each end and intermediate band about center of package. Staple to Items "F".

Vacant space between piles must not be less than 12 in. Vacant space between piles and ends of car must not be less than 30 in.

Filler blocks to level layers in piles must be secured to Items "C" as required.

See General Rules 4, 5, 9 and 15 for further details.

Sec. 2—Fig. 6

METAL PANELS IN BUNDLES WITH HIGH TENSION BANDS—GONDOLA CARS

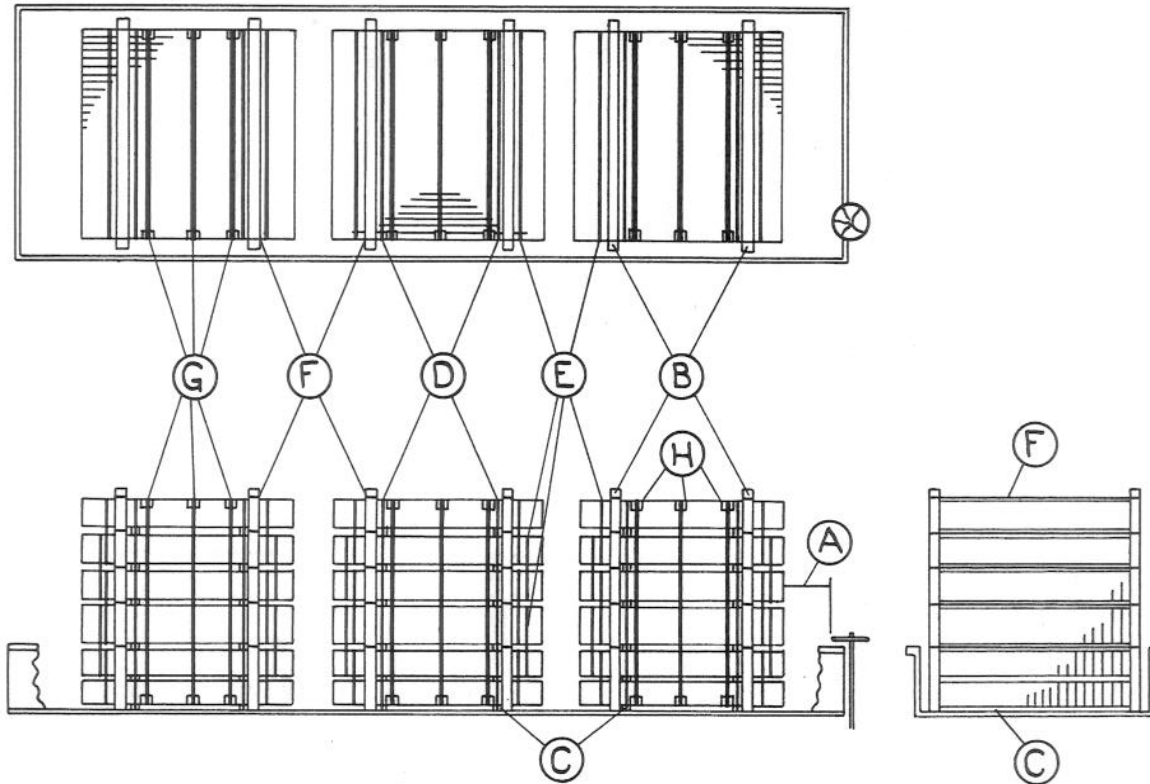

Item	No. of Pcs.	Description
A		Brake wheel clearance. See Fig. 2.
B	2 pr. per pile.	Stakes, per General Rule 10. Locate 18 in. from ends of pile.
C	2 per bundle.	2 in. x 4 in., length equal to width of pile.
D	2 per bundle.	$\frac{3}{4}$ in. x .035 in. bands. To encircle Items "C" and bundle.
E	As required	$\frac{3}{4}$ in. x .035 in. bands. Locate and apply as shown, about 12 in. from each end of pile.
F	As required.	$1\frac{1}{4}$ in. x .035 in. bands, encircling opposite Items "B", between all layers above top of car sides, and over top of pile.
G	3 per pile.	2 in. x .050 in. bands, suitably spaced, encircling entire pile.
H	As required.	Protection angles, 20 gage, 4 in. wide, applied so as to prevent displacement. Use optional.

See General Rules, 4, 5, 9, 10 and 15 for further details.

BOX CAR DOORS, VERTICALLY—GONDOLA CARS

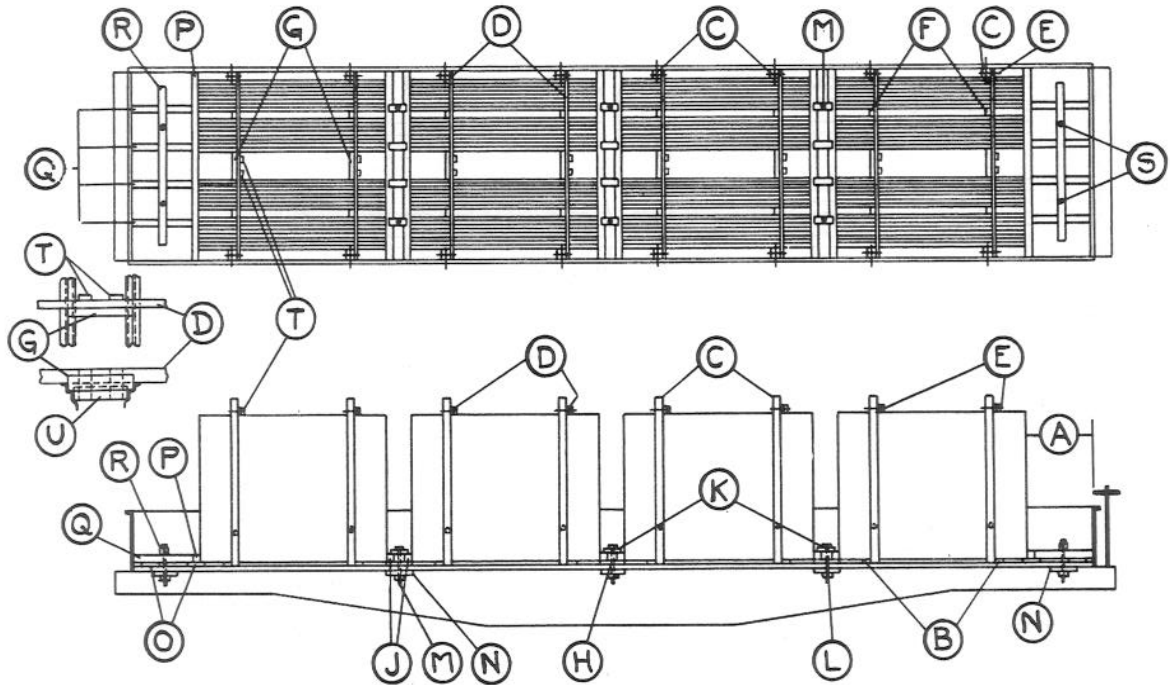

Item	No. of Pcs.	Description
A		Brake wheel clearance. See Fig. 2.
B	8	2 in. x 4 in., hardwood, length about 2 in. less than width of car.
C	16	4 in. x 4 in., hardwood, length about 8 in. higher than load. Secure to car sides with one 5/8 in. dia. bolt, with washers, in each.
D	8	2 in. x 4 in., hardwood, length to suit, ends to extend 2 in. over Items "C".
E	16	1/2 in. dia. bolts, 7 in. long, with washers. Substitute, if desired, two 30-D nails at each location.
F	16	2 in. x 2 in., hardwood, length to suit. Locate between door sets as shown. Secure each to Item "D" with two 20-D nails.
G	16	2 in. x 4 in., hardwood, length to suit. Secure bottom spacers to Items "B" and top spacers to Items "D" with four 20-D nails in each.
H	12	2 in. x 4 in. x 14 in., hardwood, equally spaced, as shown. Secure to underside of Items "J" and "L" with two 20-D nails in each.
J	6	4 in. x 4 in., hardwood, length about 2 in. less than width of car.
K	12	2 in. x 4 in. x 14 in., hardwood. Secure to top of Items "J" and "L" with two 20-D nails in each.
L	12	4 in. x 4 in. x 6 in., hardwood. Locate between Items "J" and secure by Items "H" and "K".
M	6	3/4 in. dia. bolts, length to suit, with washers. Pass through outside Items "H", "K", "L", car floor and Items "N", as shown.
N	1 ea. Item "M" 1 ea. Item "S"	4 in. x 4 in. x 18 in., hardwood, or 1/2 in. x 4 in. x 18 in. plate.
O	8	2 in. x 4 in. x 10 in., hardwood. Locate under and secure to Items "P" and each end of Items "Q" as shown with two 20-D nails in each.
P	2	4 in. x 4 in., hardwood, length about 2 in. less than width of car.
Q	8	4 in. x 4 in., hardwood, length to suit. Locate about as shown and toenail to Items "P" with two 20-D nails in each.
R	2	4 in. x 4 in., hardwood, long enough to extend about 4 in. beyond outside Items "Q". Locate about as shown.
S	4	3/4 in. dia. bolts, length to suit, with washers. Locate as shown, and pass through Items "R", car floor and Items "N".
T	16	2 in. x 4 in., hardwood, length to suit, nailed to Items "D" and Items "U" with two 20-D nails in each end.
U	8	2 in. x 4 in., hardwood, length to suit, secured as shown under Item "T".

Separator units consisting of 2 pieces Items "J" and 4 pieces each of Items "H", "K" and "L" to be assembled before being placed in car. Each unit to be secured to car floor as shown by two 3/4 in. dia. bolts, Item "M".

Doors to be assembled in sets of 8 doors each. Doors to rest on front and rear edges and back to back, with hanger castings alternating every two doors left to right.

See General Rules 4, 5, 9, 14 and 15 for further details.

Sec. 2—Fig. 8

BAR IRON, CHANNELS, ANGLES, BILLETS, ETC.—FLAT OR GONDOLA CARS

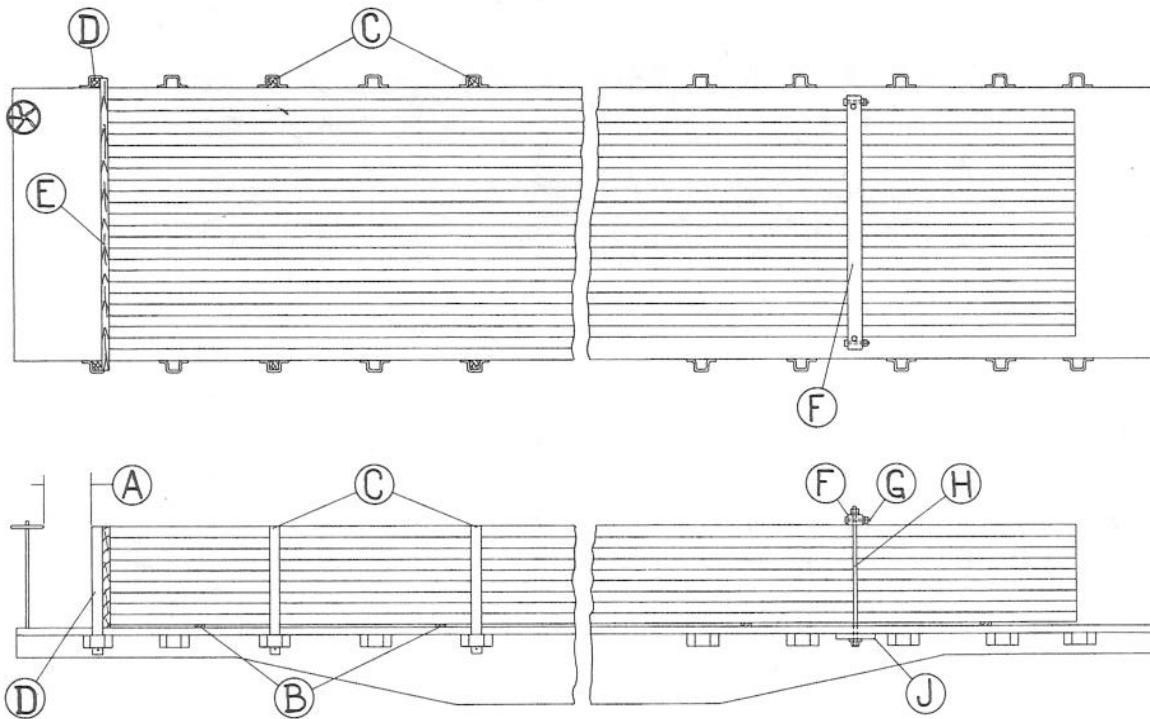

Item	No. of Pcs.	Description
A		Brake wheel clearance. See Fig. 2.
B	4	1 in. x 3 in., length about equal to width of car. Locate end pieces about 3 ft. from each end of load and the others equally spaced.
C	Pile 12 ft. to 30 ft. long, inclusive, 4 pr. Add 1 pr. for each 6 ft. or less, in length.	Stakes, hardwood, or saplings.
D	4	4 in. x 5 in., hardwood, length to suit.
E	2	3 in. thick, hardwood, height of load.
F	Pile 12 ft. to 20 ft. long, inclusive, 2. Pile over 20 ft. long, 3.	4 in. x 6 in., hardwood, length to suit.
G	2 ea. Item "F".	$\frac{1}{2}$ in. dia., with washers.
H	2 ea. Item "F".	1 in. dia., with washers.
J	1 ea. Item "H".	4 in. x 4 in. x 18 in., hardwood, or $\frac{1}{2}$ in. x 4 in. x 18 in. plate.

Items "F", "G", "H" and "J" are not required when Items "C", "D" and "E" are used, or vice versa.

Material need not be secured when loaded below top of gondola car sides with end gates raised and fastened and the total vacant space across car between piles and between the load and car sides does not exceed 18 inches.

Material too long to permit the closing of end gates must be blocked up to clear end gates and secured by Items "F", "G", "H" and "J".

Material less than 12 ft. long loaded on flat cars must have end protection consisting of boards 3 in. thick nailed to inside of Items "D", and side protection consisting of boards 2 in. thick nailed to inside of Items "C" and to 2 in. x 4 in. cleat nailed to inside ends of Item "E".

Each Item "F", "G", "H" and "J" may be substituted with two 2 in. x .050 in. high tension bands, suitably located, provided Items "C", and 2 in. x 4 in. side cleats nailed to Items "B", are used.

See General Rules 4, 5, 9, 10, 14 and 15 for further details.

Sec. 2—Fig. 9

RAILS—FLAT OR GONDOLA CARS

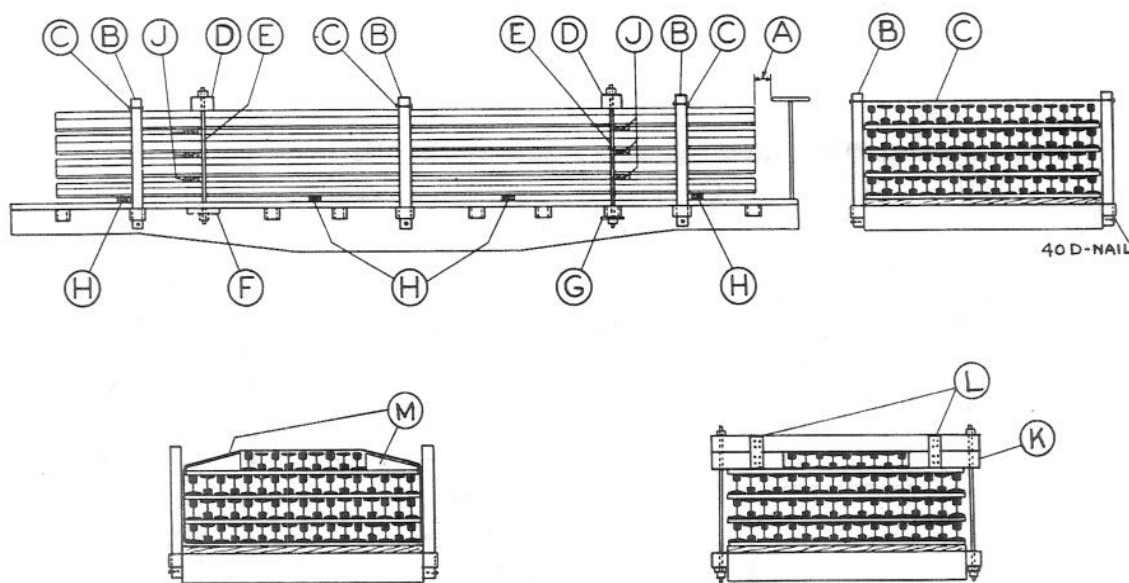

Item	No. of Pcs.	Description
A		Brake wheel clearance. See Fig. 2.
B	3 pr. per pile	Stakes, hardwood, extending not less than 3 in. above top of pile, and high enough to apply Items "C", when used
C	1 ea. pr. Items "B"	4 strands, No. 11 ga. wire. Not required for loads less than 3 ft. high.
D	2 per pile.	6 in. x 8 in., hardwood, length to suit. Use one bolt, $\frac{1}{2}$ in. dia., crosswise, with washers, at each end to prevent splitting. Locate about 7 ft. from each end of load.
E	2 ea. Item "D"	1 in. dia. with washer, as close as possible to each side of load. Secure through Items "D", floor and Items "F", or to stake pockets through Items "G", also through Items "K", when used.
F	1 ea. Item "E"	4 in. x 4 in. x 18 in., hardwood, or $\frac{1}{2}$ in. x 4 in. x 18 in. plate. Metal washers underneath this item should be as large as practicable.
G	1 ea. Item "E"	$\frac{1}{2}$ in. x 4 in. x 10 in. plate.
H	4	1 in. x 3 in., length equal to width of car. Locate end pieces about 3 ft. from each end of load and the others as far away from bands, if used, as practicable.
J	As required at 2 locations, as shown.	1 in. x 3 in., length equal to width of load. Locate about 7 ft. from each end of load.
K	2	8 in. wide, length to suit, height equal to distance between top Item "J" and Item "D". Use one bolt, $\frac{1}{2}$ in. dia., crosswise, with washers, at outer end to prevent splitting. Not required when top layer completely fills distance between Items "B" or when Items "M" are used.
L	2 ea. Item "K"	1 in. x 6 in. x 14 in. cleats. Secure each to Items "D" and "K" with eight 8-D nails. Not required when top layer completely fills distance between Items "B" or when Items "M" are used.
M	2	6 in. wide, length to suit, tapered from height of rail to 1 in. at outer end. Wires must be secured to Items "M" with three 2 in. staples or nails with head bent over. Not required when top layer completely fills distance between Items "B" or when Items "K" and "L" are used.

Items "D", "E", "F" and "G" may be substituted with three 2 in. x .050 in. high tension bands, encircling load. Locate one band about 7 ft. from each end of load and third one midway between the two.

Rails less than 12 ft. long on flat cars or above sides of gondola cars must have end and side protection consisting of boards 2 in. thick nailed to inside of stakes with side stakes spaced not more than 6 ft. apart. The height of such protection must be equal to height of load. When so protected, Items "C" to "M" inclusive, or their substitutes, may be omitted.

Material need not be secured when loaded below top of sides of gondola cars, with end gates raised and fastened, except as provided for in Rule 5.

See General Rules 4, 5, 9, 10, 12, 14 and 15 for further details.

Sec. 2—Fig. 10

PLATES—DIAGONALLY—SINGLE OR LAPPED PILES—GONDOLA CARS

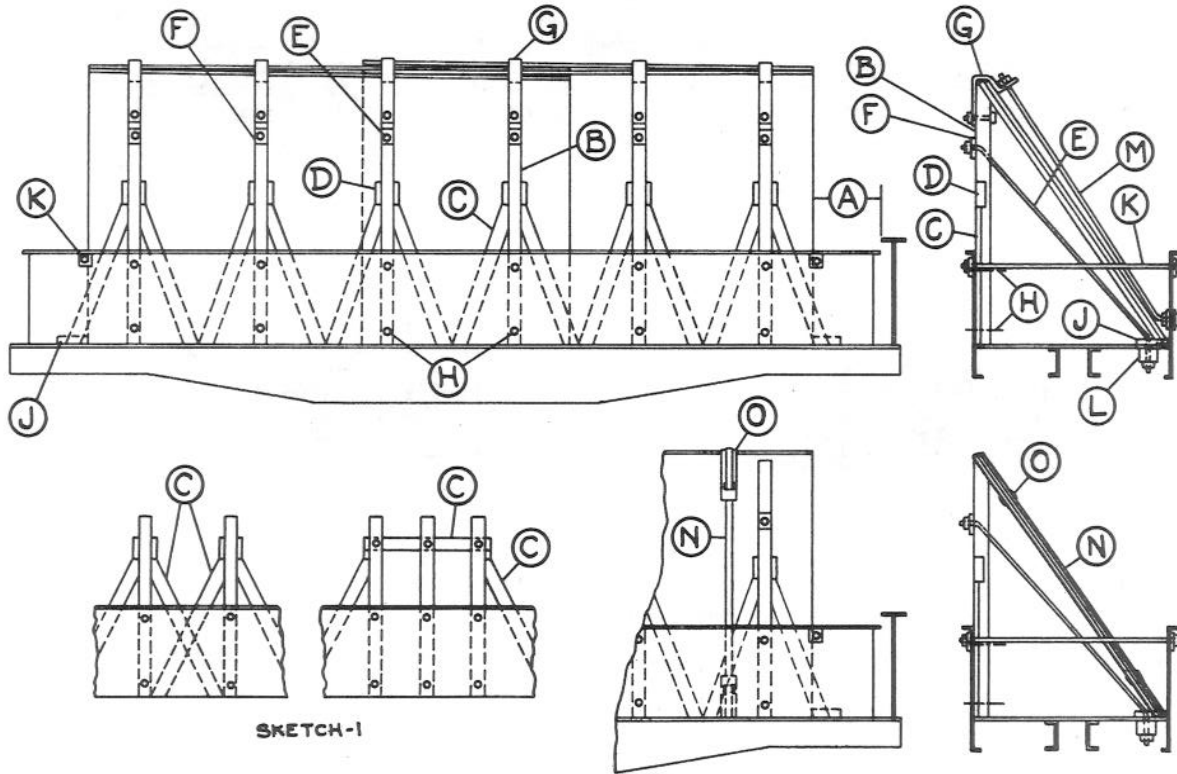

Item	No. of Pcs.	Description
A		Brake wheel clearance. See Fig. 2.
B	As required.	6 in. x 6 in., 6 in. x 8 in., 8 in. x 8 in., or 8 in. x 10 in., hardwood. See table, minimum 2 per pile. Bevel at top to provide full bearing for plates.
C	2 ea. Item "B".	2 in. x 6 in., long enough to contact Items "B", 60 percent of their length from car floor. Secure to car side and floor with four 40-D nails or one $\frac{3}{4}$ in. dia. bolt. Not required for Items "B", 4 ft. 6 in. long or less. Where Items "C" cannot be applied as shown in Figure, use method shown in Sketch 1.
D	2 ea. Item "B"	2 in. x 4 in., nailed to each Item "B" with four 30-D nails. Not required when Items "C" are not used.
E	As required.	$\frac{3}{4}$ in. x $\frac{7}{8}$ in. dia. rods (see table), through Item "B" about 8 in. from inside top edge, through Item "F", floor, close to load, Item "L", also through bearing piece, when used, unless nailed or bolted to floor.
F	1 ea. Item "B"	$\frac{1}{4}$ in. x 4 in. x 4 in. plate.
G	Single pile on two Items "B"—2. Single pile on three or more Items "B"—3. Lapped piles, 1 ea. Item "B".	$\frac{1}{2}$ in. x 3 in. plate, formed to suit, secured to Item "B" with one $\frac{3}{4}$ in. dia. bolt, with washer. May be secured to car side when Item "B" does not extend more than 12 in. above top of car side. Not required when Items "N" and "O" are used.

Sec. 2—Fig. 10

PLATES—DIAGONALLY—SINGLE OR LAPPED PILES—GONDOLA CARS

Item	No. of Pcs.	Description
H	2 ea. Item "B".	$\frac{3}{4}$ in. or $\frac{7}{8}$ in. dia. bolts. See table.
J	2 per pile.	6 in. x 8 in., hardwood, length to suit, against edge of plates, each secured with two $\frac{3}{4}$ in. dia. bolts, through floor and Item "L". Substitute, if desired, for each Item "J", one additional Item "K", located about six inches above floor, or bearing piece, if used.
K	2 per pile.	$\frac{7}{8}$ in. dia. rod, against edge of plates, with nuts and washers.
L	1 ea. Items "E" and "J"	4 in. x 4 in. x 18 in., hardwood, or $\frac{1}{2}$ in. x 4 in. x 18 in. plate.
M	1 ea. Item "G"	$\frac{3}{4}$ in. dia. rod. Pass through and secure to Item "G", with nut, and close to bottom of opposite car side. Secure with two nuts, one inside and one outside, with washers. Not required when Items "N" and "O" are used.
N	Single pile on two Items "B"—2. Single pile on three or more Items "B"—3. Lapped piles, 1 between ea. Item "B".	2 in. x .050 in. high tension bands encircling all plates and passed through each slot of top and bottom Item "O". Permitted only when all plates in pile equal or exceed $2\frac{1}{2}$ in. in thickness Not required when Items "G" and "M" are used.
O	2 ea. Item "N"	Protection plates formed to suit. $\frac{3}{16}$ in. x 6 in. x 48 in., with 2 in. x 3 in. slot at each end. Not required when Items "G" and "M" are used.

Determine number of Items "B" required, by dividing total weight of load by load allowed per Item "B", in following table:

Maximum Load Allowed per Item "B"	Size of Item "B"	Length of Item "B"	Diagonal Tie Rods		Bolts Securing Each Item "B" to Side of Car	
			Number	Dia.	Number	Dia.
9,000 lbs.	6 in. x 6 in.	Over 5 ft.	1 ea. Item "B"	$\frac{3}{4}$ in.	2	$\frac{3}{4}$ in.
12,000 lbs.	6 in. x 6 in.	5 ft. or less	1 ea. Item "B"	$\frac{3}{4}$ in.	2	$\frac{3}{4}$ in.
13,000 lbs.	6 in. x 8 in.	Over 5 ft.	1 ea. Item "B"	$\frac{7}{8}$ in.	2	$\frac{7}{8}$ in.
17,000 lbs.	6 in. x 8 in.	5 ft. or less	1 ea. Item "B"	$\frac{7}{8}$ in.	2	$\frac{7}{8}$ in.
20,000 lbs.	8 in. x 8 in.	Over 5 ft.	2 ea. Item "B"	$\frac{7}{8}$ in.	2	$\frac{7}{8}$ in.
25,000 lbs.	8 in. x 10 in.	Over 5 ft.	2 ea. Item "B"	$\frac{7}{8}$ in.	2	$\frac{7}{8}$ in.

Items "G" and "M" or Items "N" and "O" not required for single plate $2\frac{1}{2}$ in. or over, in thickness.

Place center line of plates above longitudinal center line of car, using filler pieces between Items "B" and car sides, if necessary. Top plate must contact side of car and rest on floor, or on bearing pieces, if used. Diagonal plates must not exceed 75 per cent of load weight limit. Bearing pieces used for loading or unloading, must be opposite each Item "B" securely nailed or bolted to floor or sides.

Load must not extend beyond car sides.

See General Rules 4, 5, 7, 9, 10, 14 and 15 for further details.

ROUND FLAT PLATES—DIAGONALLY—GONDOLA CARS

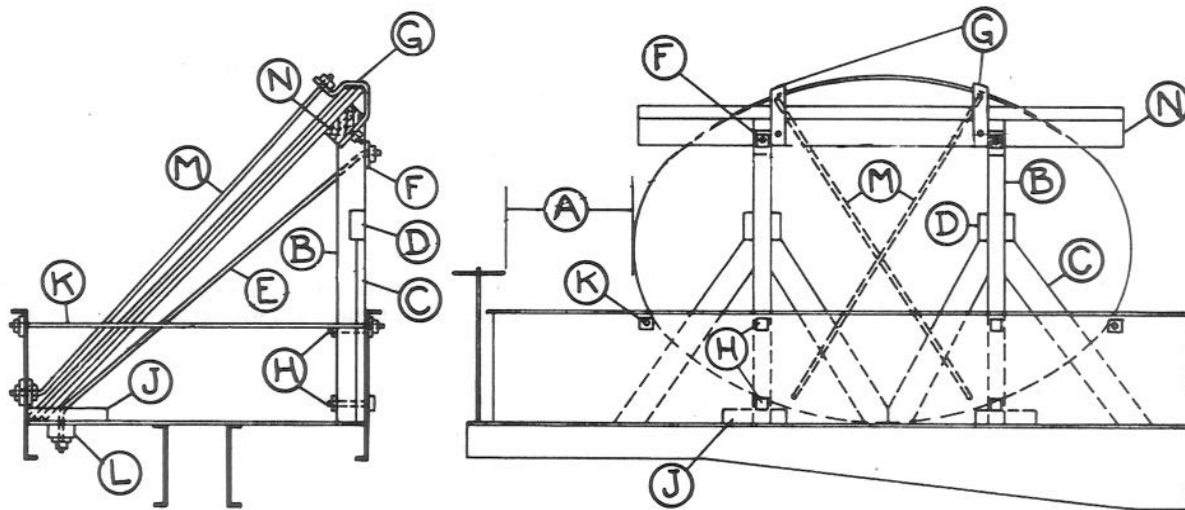

Item	No. of Pcs.	Description
A		Brake wheel clearance. See Fig. 2.
B	2 per pile.	6 in. x 6 in. x 8 in., 8 in. x 8 in., or 8 in. x 10 in., hardwood. See table. Bevel at top to provide full bearing for plates.
C	2 ea. Item "B"	2 in. x 6 in., long enough to contact Items "B", sixty percent of their length from car floor. Secure to car side and floor with four 40-D nails or one 3/4 in. dia. bolt. Not required for Items "B", 4 ft. 6 in. long or less.
D	2 ea. Item "B"	2 in. x 4 in., nailed to each Item "B" with four 30-D nails. Not required when Items "C" are not used.
E	1 ea. Item "B"	3/4 in. or 7/8 in. dia. rod (see table), through Item "B" about 8 in. from inside top edge, through Item "F", floor, close to load, Item "L", also through bearing piece, when used, unless nailed or bolted to floor.
F	1 ea. Item "B"	1/4 in. x 4 in. x 4 in. plate.
G	1 ea. Item "B"	1/2 in. x 3 in. plate, formed to suit, secured to Item "N" with one 3/4 in. dia. bolt with washer.
H	2 ea. Item "B"	3/4 in. or 7/8 in. dia. bolts. See table.
J	2 per pile.	6 in. x 8 in., hardwood, length to suit, against edge of plates, each secured with two 3/4 in. dia. bolts, through floor and Item "L".
K	2 per pile	7/8 in. dia. rod, against edge of plates, with nuts and washers.
L	1 ea. Items "E" and "J"	4 in. x 4 in. x 18 in., hardwood, or 1/2 in. x 4 in. x 18 in. plate.
M	1 ea. Item "G"	3/4 in. dia. rod. Pass through and secure to Item "G" with nut, and close to bottom of opposite car side, as shown. Secure with two nuts, one inside and one outside, with washer.
N	1 per pile	4 in. x 8 in., hardwood, length to suit, secured to each Item "B" with one 3/4 in. dia. bolt, countersunk.

Determine number of Items "B" required, by dividing total weight of load by load allowed per Item "B", in following table:

Maximum Load Allowed per Item "B"	Size of Item "B"	Length of Item "B"	Diagonal Tie Rods		Bolts Securing Each Item "B" to Side of Car.	
			Number	Dia.	Number	Dia.
9,000 lbs.	6 in. x 6 in.	Over 5 ft.	1 ea. Item "B"	3/4 in.	2	3/4 in.
12,000 lbs.	6 in. x 6 in.	5 ft. or less	1 ea. Item "B"	3/4 in.	2	3/4 in.
13,000 lbs.	6 in. x 8 in.	Over 5 ft.	1 ea. Item "B"	7/8 in.	2	7/8 in.
17,000 lbs.	6 in. x 8 in.	5 ft. or less	1 ea. Item "B"	7/8 in.	2	7/8 in.
20,000 lbs.	8 in. x 8 in.	Over 5 ft.	2 ea. Item "B"	7/8 in.	2	7/8 in.
25,000 lbs.	8 in. x 10 in.	Over 5 ft.	2 ea. Item "B"	7/8 in.	2	7/8 in.

Place center line of plates above longitudinal center line of car, using filler pieces between Items "B", and car sides if necessary. Top plate must contact side of car and rest on floor, or on bearing pieces, if used. Diagonal plates must not exceed 75 percent of load weight limit. Bearing pieces used for loading or unloading must be opposite each Item "B", securely nailed or bolted to floor or sides.

Load must not extend beyond car sides.

See General Rules 4, 5, 7, 9, 10, 14 and 15 for further details.

Sec. 2—Fig. 12

ROUND DISHED OR FLANGED PLATES—DIAGONALLY—GONDOLA CARS

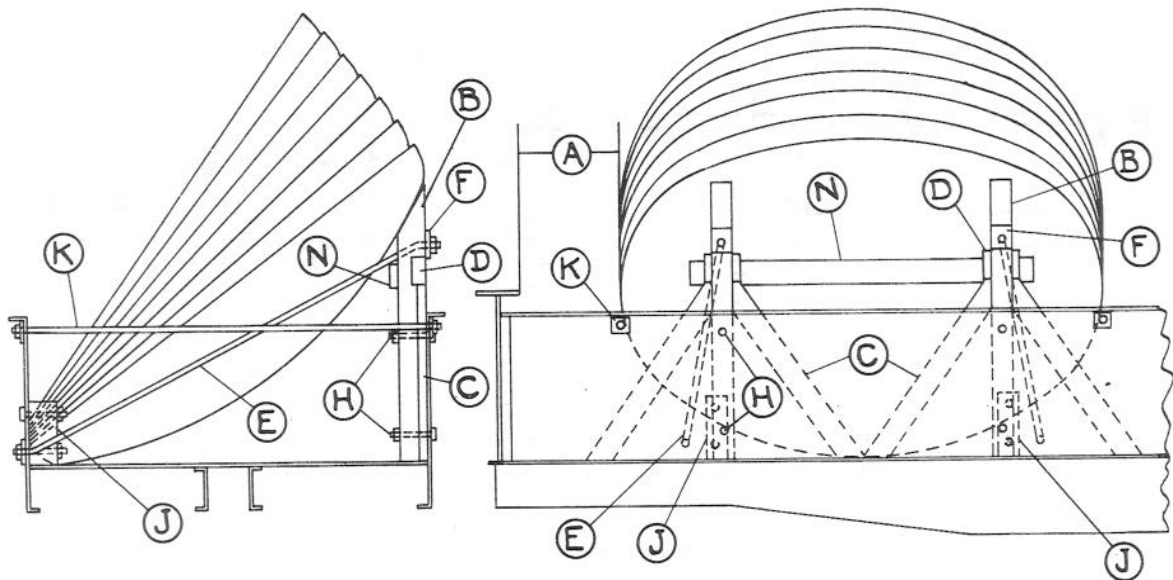

Item	No. of Pcs.	Description
A		Brake wheel clearance. See Fig. 2.
B	2 per pile	6 in. x 6 in., 6 in. x 8 in., 8 in. x 8 in., or 8 in. x 10 in., hardwood. See table. Bevel at top.
C	2 ea. Item "B"	2 in. x 6 in., long enough to contact Items "B", sixty percent of their length from car floor. Secure to car side and floor with four 40-D nails or one 3/4 in. dia. bolt. Not required for Items "B", 4 ft. 6 in. long or less.
D	2 ea. Item "B"	2 in. x 4 in., nailed to each Item "B" with four 30-D nails. Not required when Items "C" are not used.
E	1 ea. Item "B"	3/4 in. or 7/8 in. dia. rod (see table), through Item "B" about 8 in. from inside top edge, and through opposite car side near bottom, as shown, forming a cradle for dished portion of plates.
F	1 ea. Item "B"	1/4 in. x 4 in. x 4 in. plate.
G		VACANT.
H	2 ea. Item "B"	3/4 in. or 7/8 in. dia. bolts. See table.
J	2 per pile	6 in. x 8 in., hardwood, length to suit, against edge of plates, each secured to car side with two 3/4 in. dia. bolts.
K	2 per pile	7/8 in. dia. rod, against edge of plates, with nuts and washers.
L		VACANT.
M		VACANT.
N	1 per pile	2 in. x 6 in., hardwood, length to suit. Locate against Item "E" or dished portion of plate and secure to each Item "B" with one 3/4 in. dia. bolt.

Determine number of Items "B" required, by dividing total weight of load by load allowed per Item "B", in following table:

Maximum Load Allowed per Item "B"	Size of Item "B"	Length of Item "B"	Diagonal Tie Rods		Bolts Securing Each Item "B" to Side of Car	
			Number	Dia.	Number	Dia.
9,000 lbs.	6 in. x 6 in.	Over 5 ft.	1 ea. Item "B"	3/4 in.	2	3/4 in.
12,000 lbs.	6 in. x 6 in.	5 ft. or less	1 ea. Item "B"	3/4 in.	2	3/4 in.
13,000 lbs.	6 in. x 8 in.	Over 5 ft.	1 ea. Item "B"	7/8 in.	2	7/8 in.
17,000 lbs.	6 in. x 8 in.	5 ft. or less	1 ea. Item "B"	7/8 in.	2	7/8 in.
20,000 lbs.	8 in. x 8 in.	Over 5 ft.	2 ea. Item "B"	7/8 in.	2	7/8 in.
25,000 lbs.	8 in. x 10 in.	Over 5 ft.	2 ea. Item "B"	7/8 in.	2	7/8 in.

Place center line of plates above longitudinal center line of car, using filler pieces between posts and car sides, if necessary. Top plate must contact side of car and rest on floor, or on bearing pieces, if used. Diagonal plates must not exceed 75 percent of load weight limit. Bearing pieces used for loading or unloading must be opposite each post, securely nailed or bolted to floor or sides.

Load must not extend beyond car sides.

See General Rules 4, 5, 7, 9, 10, 14 and 15 for further details.

Sec. 2—Fig. 13

PLATES—DIAGONALLY—UNLAPPED PILES—GONDOLA CARS

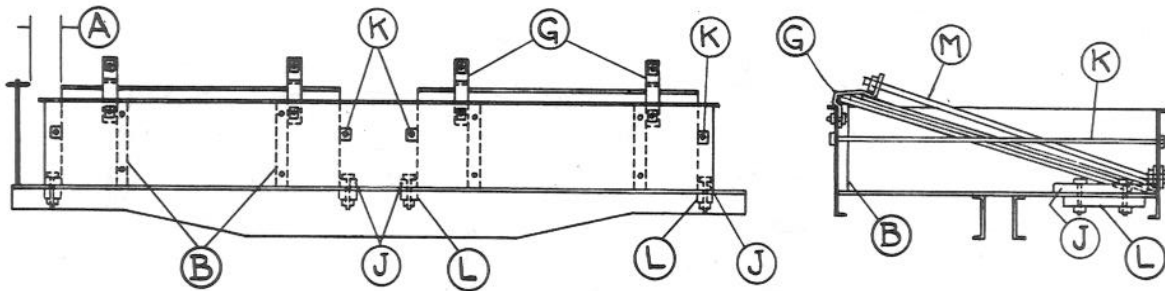

Item	No. of Pcs.	Description
A		Brake wheel clearance. See Fig. 2.
B	2 per pile	4 in. x 4 in., hardwood, long enough to extend slightly above top of car side, for each 9,000 lbs. of load; placed in stake pockets or bolted to car side with two $\frac{3}{4}$ in. dia. bolts. Not required when weight of pile (1 per car side) does not exceed 9,000 lbs.
C		VACANT.
D		VACANT.
E		VACANT.
F		VACANT.
G	2 per pile	$\frac{1}{2}$ in. x 3 in. plate, formed to suit, secured to car side with one $\frac{3}{4}$ in. dia. bolt, with washer. May be secured with top bolt of Item "B".
H		VACANT.
J	2 per pile	6 in. x 8 in., hardwood, length to suit, against edge of plates, each secured with two $\frac{3}{4}$ in. dia. bolts, with washers, through floor and Item "L".
K	2 per pile	$\frac{7}{8}$ in. dia. rod, against edge of plates, with nuts and washers.
L	1 ea. Item "J".	4 in. x 4 in. x 18 in., hardwood, or $\frac{1}{2}$ in. x 4 in. x 18 in. plate.
M	1 ea. Item "G".	$\frac{3}{4}$ in. dia. rod. Pass through and secure to Item "G", with nut, and close to bottom of opposite car side. Secure with two nuts, one inside and one outside, with washers.

Plates loaded in this manner, on cars with fish-belly type side sills, must not exceed 50 percent of the load weight limit. Other cars of steel or steel underframe construction must not exceed 25 percent of the load weight limit.

Items "J" and "K" not required between piles contacting each other when loaded diagonally on opposite sides of car.

Load must not extend beyond car sides.

See General Rules 4, 5, 7, 9, 10, 14 and 15 for further details.

THIS PAGE WAS LEFT BLANK INTENTIONALLY

Sec. 2—Fig. 14

WIDE PLATES—FLAT CARS

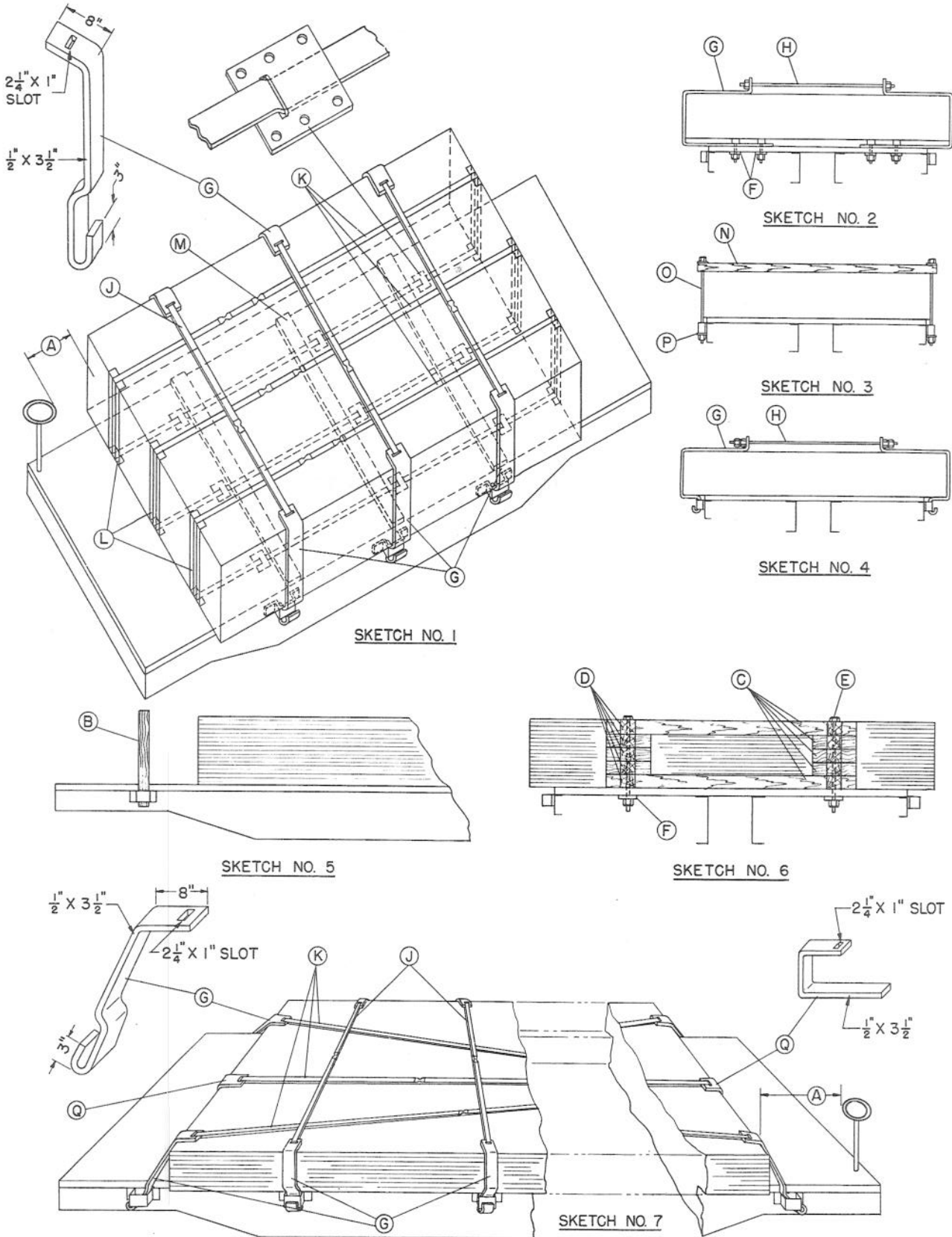

Sec. 2—Fig. 14

WIDE PLATES—FLAT CARS

Item	No. of Pcs.	Description
A		Brake wheel clearance. See Fig. 2.
B	4	4 in. x 5 in., hardwood, length to suit. Locate not more than 3 ft. from end of load. Not required when loaded per Sketches 1 or 7 or when end blocking, Sketch 6, is used.
C	2	6 in. x 8 in. x 6 ft., hardwood, 8 in. side down. Top of blocking must be flush with top of load. Spacing pieces, 8 in. wide x 18 in. long may be used at each end of Item "C" to obtain proper height. Not required when loaded per Sketches 1, 3 or 7 or when end blocking, Sketch 5, is used.
D	As required.	6 in. x 8 in. x 30 in., hardwood, 8 in. side down. Top of blocking must be flush with top of load. Not required when loaded per Sketches 1, 3 or 7 or when end blocking, Sketch 5, is used.
E	12	$\frac{3}{4}$ in. dia. bolts, length to suit, passed through Items "C", "D", floor and Item "F". Not required when loaded per Sketches 1, 3 or 7 or when end blocking, Sketch 5, is used.
F	As required.	4 in. x 4 in. x 18 in., hardwood, or $\frac{1}{2}$ in. x 4 in. x 18 in. plate. Not required when loaded per Sketches 1, 3 or 7 or when end blocking, Sketch 5, is used.
G	3 per pile 28 ft. long or less, except, 4 additional when Sketch 7 is used; more as required.	$\frac{1}{2}$ in. x $3\frac{1}{2}$ in., length to suit, per Sketches 1, 2, 4 and 7. Locate not more than 7 ft. from end of pile, nor spaced more than 7 ft. apart. Secure to floor and Item "F" with two $\frac{3}{4}$ in. dia. bolts in each as shown in Sketch 2, or form end and secure to stake pockets as shown in Sketches 1, 4 and 7. For plate narrower than car, substitute, if desired, at each location, one pair of 4 in. x 5 in. hardwood stakes. Not required when loaded per Sketch 3.
H	As required.	$\frac{3}{4}$ in. dia., length to suit, passed through Items "G". Not required when loaded per Sketches 1, 3 or 7.
J	3 per pile 28 ft. long or less, except, 2 additional when Sketch 7 is used; more as required.	2 in. x .050 in. high tension bands passed through Items "G" or "Q" and sealed in center, except for loads secured per Sketch 7. When Items "G" consist of stakes, bands to encircle pile and be sealed in center. Not required for loads per Sketches 2, 3 or 4.
K	3	2 in. x .050 in. high tension bands, located as shown in Sketches 1 or 7. Use three mechanical brakemen on each band, except, not required for loads per Sketch 7. Secure brakemen to floor with six $\frac{1}{2}$ in. x $1\frac{3}{4}$ in. drive screws in each. Not required for loads per Sketches 2, 3 or 4.
L	2 ea. Item "K".	Protection angles, 20 ga., 4 in. wide, applied so as to prevent displacement. Not required for loads per Sketch 7.
M	3 per pile.	$\frac{1}{2}$ in. x 3 in. wood, length equal to width of car. Locate as shown in Sketch 1 and nail to floor with four 6-D nails in each. Not required for loads per Sketches 2, 3, 4 or 7.
N	3 per pile 28 ft. long or less; more as required.	4 in. x 6 in., hardwood, length equal to width over stake pockets. Use one $\frac{1}{2}$ in. dia. bolt, crosswise, with washers, at each end or one $\frac{1}{4}$ in. x 4 in. metal strip, length equal to width over stake pocket, on top of clamping piece, to prevent splitting. Locate not more than 7 ft. from ends of pile, nor spaced more than 7 ft. apart. Not required for loads per Sketches 1, 2, 4 or 7.
O	2 ea. Item "N".	$\frac{3}{4}$ in. dia., length to suit, with washers at top. Pass through Item "N", stake pocket and Item "P". Not required for loads per Sketches 1, 2, 4 or 7.
P	1 ea. Item "O".	$\frac{1}{2}$ in. x 4 in. x 10 in. plate. Not required for loads per Sketches 1, 2, 4 or 7.
Q	2 per pile, Sketch 7 only.	$\frac{1}{2}$ in. x $3\frac{1}{2}$ in. bracket, length and height to suit per Sketch 7. Required only when plates are of different widths.

When loads per Sketches 1 or 7 consist of uneven lengths, the two longest plates must be loaded, one on the bottom and the other on the top, with intermediate plates flush with ends of pile. The shortest plates must be protected by three crosswise ties.

When loads per Sketches 1 or 7 consist of uneven widths, the individual plates must alternate to provide even edges of pile and equal distribution of weight.

Items "O" may pass through floor and 4 in. x 4 in. x 18 in. hardwood cleat, or $\frac{1}{2}$ in. x 4 in. x 18 in. plate underneath floor. Locate as close to each side of pile as possible.

Sketch 3 may be used for plates not extending beyond stake pockets.

The length of bearing strips, if used, must be equal to width of car.

See General Rules 4, 5, 7, 9, 10, 14 and 15 for further details.

Sec. 2—Fig. 15

WIDE PLATES—ON TOP OF CAR SIDES—GONDOLA CARS WITH STEEL SIDES NOT OVER 48 IN. HIGH

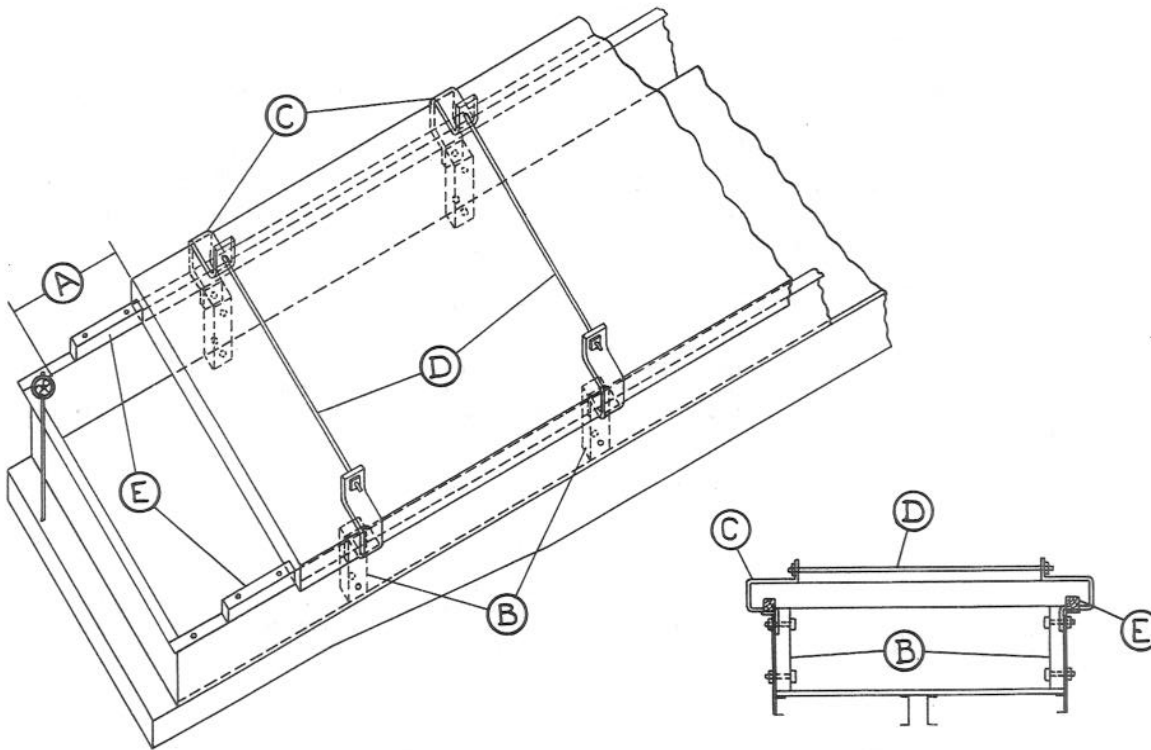

Item	No. of Pcs.	Description
A		Brake wheel clearance. See Fig. 2.
B	3 per pile 15 ft. long or less; more as required.	4 in. x 6 in., hardwood. Locate not more than 18 in. from ends of pile nor spaced more than 6 ft. apart. Secure with two $\frac{3}{4}$ in. dia. bolts, with washers.
C	1 ea. Item "B"	$\frac{1}{2}$ in. x $3\frac{1}{2}$ in., length to suit. Locate between Item "B" and side of car and secure with one $\frac{3}{4}$ in. dia. bolt.
D	1 ea. pair Items "C"	$\frac{3}{4}$ in. dia. rod, length to suit, passed through Items "C".
E	4 per pile	4 in. x 4 in. x 30 in., hardwood. Locate on top side angle against ends of pile. Secure each with two $\frac{3}{4}$ in. dia. bolts, with washers.

Weight of plates on top of car sides must not exceed thirty percent of load weight limit.

Material secured in accordance with other rules and figures may be loaded on floor of car.

See General Rules 4, 5, 7, 9 and 15 for further details.

THIS PAGE WAS LEFT BLANK INTENTIONALLY

Sec. 2—Fig. 16

STEEL PLATES OR SHEETS, NOT OVER 1 IN. THICK, NOT EXCEEDING 20 IN. ABOVE FLOOR, SECURED WITH HIGH TENSION WIRES OR HIGH TENSION BANDS. ENDS OF LOAD MUST NOT BE LESS THAN 6 FT. FROM ENDS OF CAR—FLAT CARS

Item No. of Pcs. Description

OILED OR HIGHLY FINISHED

Weight of Pile	No. 8 ga. wires		1¼ in. x .035 in. bands		2 in. x .050 in. bands	
	C-wise of car	L-wise of car	C-wise of car	L-wise of car	C-wise of car	L-wise of car
10,000 lbs. or less.....	6	3	3	2	2	2
Over 10,000 lbs. to 20,000 lbs.....	8	4	4	2	2	2
Over 20,000 lbs. to 50,000 lbs.....	14	10	7	5	3	2
Over 50,000 lbs.....	16	12	8	6	4	3

C Overall ties. As required. Wires or bands, encircling entire load, lengthwise of car, suitably spaced. Draw taut but not too tight. Not required for a single pile.

Weight of Load	No. 8 ga. wires	1¼ in. x .035 in. bands	2 in. x .050 in. bands
50,000 lbs. or less.....	10	5	3
Over 50,000 lbs.....	14	7	4

D Pile 60 in. wide or less, 2. 2 in. x 3 in., hardwood, same length as pile, beveled ends, tied to pile with Items "B", lengthwise of car. When two sections are used per skid, account length of pile, place one piece of 20 ga. sheet, 3 in. x 8 in., on top of skid and one on bottom, at joint, and nail each to skid with eight 4-D nails.
 Pile over 60 in. wide, 3.

E 1 ea. side of load Guide strips, 3 in wide, slightly thinner than Item "D", continuous full length of car. Locate both inside or outside of, and not more than 1 in. from Items "D". Nail to floor with 20-D nails spaced about 18 in. apart.

F As required. Protection angles, 20 ga., 4 in. wide, applied so as to prevent displacement.

If units vary in width, apply wood fillers so that they will not become displaced, and so as to make pile uniform at points where Items "B" or "C" are applied.

Single piles having units longer than the rest of pile, must have the longer units loaded on top and secured by all Items "B", crosswise of car only. The total height of these units must not exceed 2 in. and must not extend more than 2 ft. beyond either end of pile.

Load consisting of more than two piles must have end piles placed so as to brace intermediate piles.

Two or more side by side piles must be tied together with 4 additional wires, or 2 additional bands, Items "B", crosswise of car.

Vertical separators used between piles must be secured to prevent displacement. Horizontal separators are prohibited.

See General Rules 4, 5, 9, 14 and 15 for further details.

Sec. 2—Fig. 17

PACKAGED STEEL PLATES OR SHEETS, NOT OVER 1 IN. THICK, NOT EXCEEDING 20 IN. ABOVE FLOOR, SECURED WITH HIGH TENSION BANDS. ENDS OF LOAD MUST NOT BE LESS THAN 6 FT. FROM ENDS OF CAR—RETARDED FLOATING LOAD—FLAT CARS

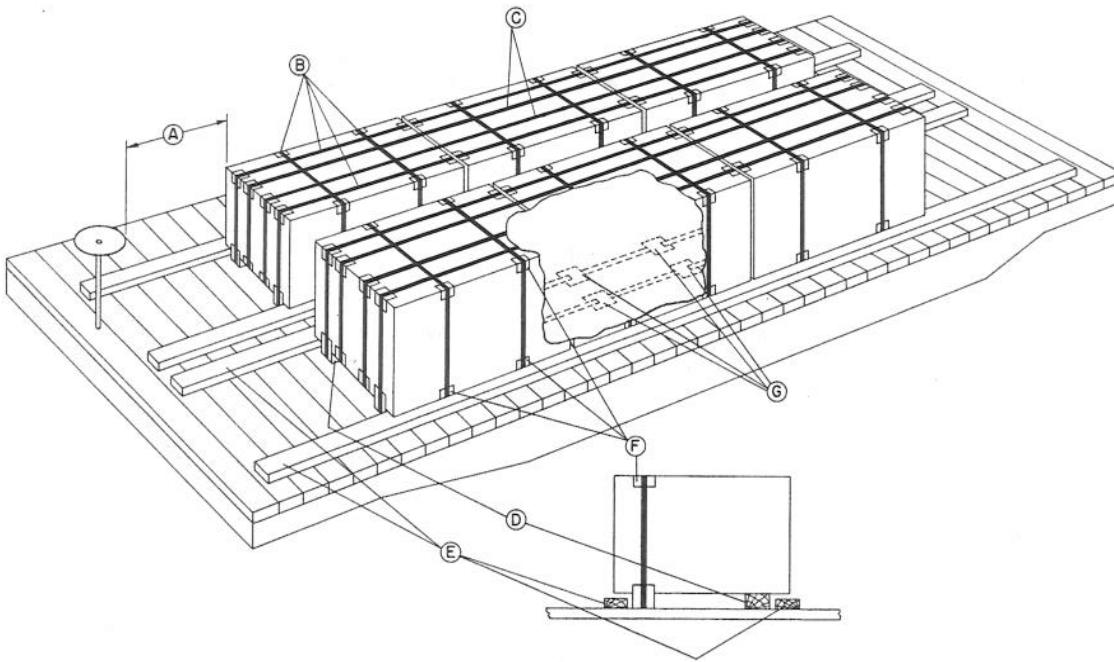

- Item No. of Pcs. Description
- A Brake wheel clearance. See Fig. 2.
- B Individual ties. Wires or bands, suitably spaced. Draw taut but not too tight. As required.

UNOILED STEEL PLATES OR SHEETS

Weight of Pile	No. 8 ga. wires		1 1/4 in. x .035 in. bands		2 in. x .050 in. bands	
	C-wise of car	L-wise of car	C-wise of car	L-wise of car	C-wise of car	L-wise of car
10,000 lbs. or less	4	2	2	2	2	2
Over 10,000 lbs. to 20,000 lbs.	6	4	3	2	2	2
Over 20,000 lbs. to 50,000 lbs.	12	8	6	4	3	2
Over 50,000 lbs.	16	12	8	6	4	3

Sec. 2—Fig. 17

PACKAGED STEEL PLATES OR SHEETS, NOT OVER 1 IN. THICK, NOT EXCEEDING 20 IN. ABOVE FLOOR, SECURED WITH HIGH TENSION BANDS. ENDS OF LOAD MUST NOT BE LESS THAN 6 FT. FROM ENDS OF CAR—RETARDED FLOATING LOAD—FLAT CARS

Item No. of Pcs. Description

OILED OR HIGHLY FINISHED

Weight of Pile	No. 8 ga. wires		1 1/4 in. x .035 in. bands		2 in. x .050 in. bands	
	C-wise of car	L-wise of car	C-wise of car	L-wise of car	C-wise of car	L-wise of car
10,000 lbs. or less	6	3	3	2	2	2
Over 10,000 lbs. to 20,000 lbs.	8	4	4	2	2	2
Over 20,000 lbs. to 50,000 lbs.	14	10	7	5	3	2
Over 50,000 lbs.	16	12	8	6	4	3

C Overall ties. As required. Bands, encircling entire row, lengthwise of car, suitably spaced.

Weight of Row	2 in. x .050 in. bands
30,000 lbs. or less	2
Over 30,000 lbs. to 50,000 lbs.	3
Over 50,000 lbs.	4

D Pile 60 in. wide or less, 2. 2 in. x 3 in., hardwood, same length as pile, beveled ends, tied to pile with Items "B", lengthwise of car. When two sections are used per skid, account length of pile, place one piece of 20 ga. sheet, 3 in. x 8 in., on top of skid and one on bottom, at joint, and nail each to skid with eight 4-D nails.
 Pile over 60 in. wide, 3.

E 1 ea. side of row. Guide strips, 3 in. wide, slightly thinner than Item "D", continuous full length of car. Locate both inside or outside of, and not more than 1 in. from Items "D". Nail to floor with 20-D nails spaced about 18 in. apart.

F As required. Protection angles, 20 ga., 4 in. wide, applied so as to prevent displacement.

G 2 ea. Item "C" Snubber plates. Locate about midway of each row and space about 24 in. apart.

Vertical separators if used between piles must be secured to prevent displacement. Horizontal separators are prohibited.

See General Rules 4, 5, 9, 14 and 15 for further details.

Sec. 2—Fig. 18

UNOILED STEEL PLATES OR SHEETS, OVER $\frac{1}{8}$ IN. THICK, LENGTHWISE, SECURED WITH CLAMPS AND RODS. HEIGHT MUST NOT EXCEED 24 IN. ABOVE FLOOR—GONDOLA CARS

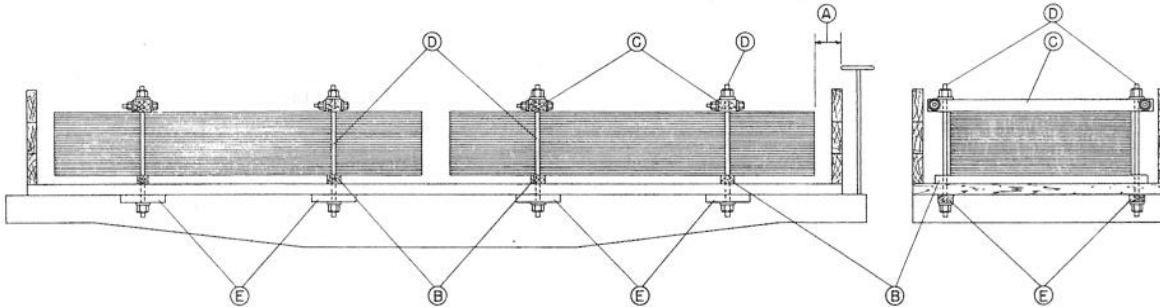

Item	No. of Pcs.	Description
A		Brake wheel clearance. See Fig. 2.
B	Pile 30 ft. long or less, 2; pile over 30 ft. long, 3	3 in. x 3 in., hardwood, long enough to extend 6 in. beyond each side of pile. Use optional on cars with wood floors.
C	Pile 30 ft. long or less, 2; pile over 30 ft. long, 3	4 in. x 6 in., hardwood, length approximately the inside width of car. Use one bolt, $\frac{1}{2}$ in. dia., crosswise, with washers at each end, to prevent splitting.
D	2 ea. Item "C"	$\frac{3}{4}$ in. diameter rod, with washer, through Items "C", "B", floor of car and Item "E".
E	1 ea. Item "D"	4 in. x 4 in. x 18 in., hardwood, or $\frac{1}{2}$ in. x 4 in. x 18 in. plate.

Items "B" to "E", inclusive, not required when total vacant space between piles and between piles and car sides, across car, does not exceed 8 in.

If plates vary in width, wooden fillers, secured to rods, must be used to make pile uniform.

1 in. x 3 in. strips must be securely nailed to vertical separators, when used, to prevent displacement.

Where width of piles permit, they should be loaded side by side, in order to keep height of load as low as possible.

The use of horizontal separators is prohibited.

When load extends about entire length of car and is lapped at center or staggered, maximum weight must not exceed marked capacity of car.

Plates may overlap each other between truck centers, provided the end of each end pile is not more than one ft. from end of car and that the specified weight limitations in Rule 4 are not exceeded at overlapped portion of load. Extreme height of load, measured at any point, must not exceed 30 inches from floor. Add one (1) clamp, Items "B", "C", "D" and "E" located near center of overlapped portion of load.

See General Rules 4, 5, 9, 10, 12, 14 and 15 for further details.

THIS PAGE WAS LEFT BLANK INTENTIONALLY

Sec. 2—Fig. 19

UNOILED STEEL PLATES OR SHEETS, LENGTHWISE, SECURED WITH HIGH TENSION WIRES OR HIGH TENSION BANDS. HEIGHT OF PILES, MEASURED AT OUTER ENDS, MUST NOT EXCEED 24 IN. ABOVE FLOORS, NOR WIDTH OF INDIVIDUAL UNITS—GONDOLA CARS

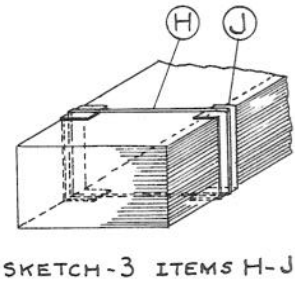
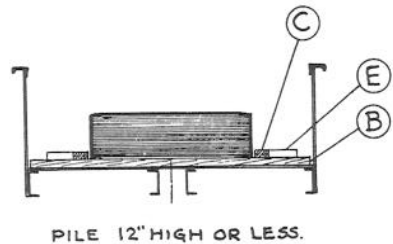
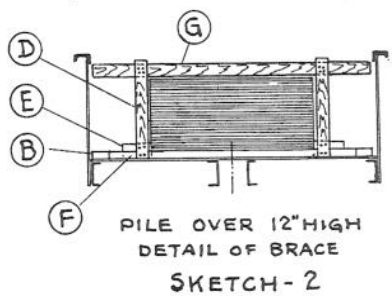
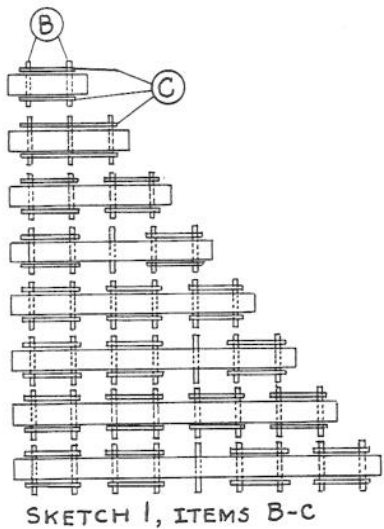
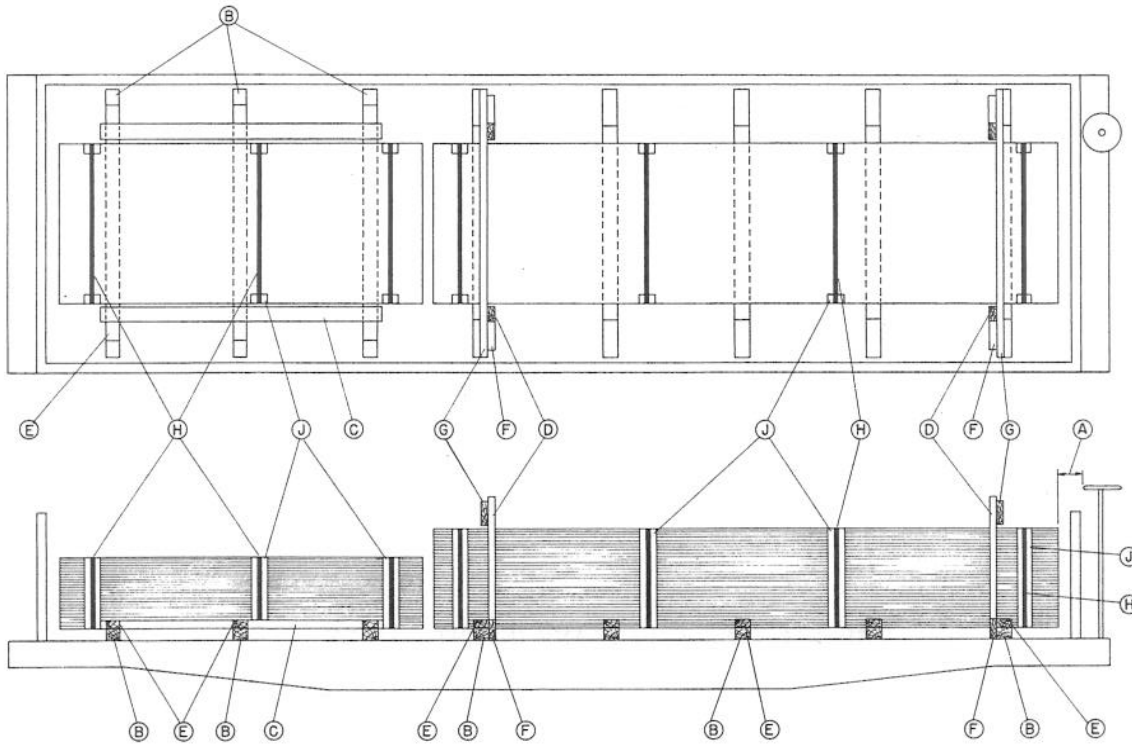

Sec. 2—Fig. 19

UNOILED STEEL PLATES OR SHEETS, LENGTHWISE, SECURED WITH HIGH TENSION WIRES OR HIGH TENSION BANDS. HEIGHT OF PILES, MEASURED AT OUTER ENDS, MUST NOT EXCEED 24 IN. ABOVE FLOOR, NOR WIDTH OF INDIVIDUAL UNITS—GONDOLA CARS

Item	No. of Pcs.	Description
A		Brake wheel clearance. See Fig. 2.
B	As required. Sketch 1.	2 in. x 3 in., hardwood, length about equal to width of car. Locate one about 2 ft. from each end of pile and the others so that spaces between them does not exceed 10 ft. When ends of piles overlap each other, the bearing pieces must be placed so as to fully support the overlapped portion, even though additional bearing pieces may be necessary. Substitute, if desired, 1 in. x 3 in., hardwood, where Items "C" or "D" are not required.
C	As required. Sketch 1.	2 in. x 4 in., hardwood, long enough to extend about 4 in. beyond Items "B". Locate about 1 in. from side of pile and secure to each Item "B" with three 20-D nails. Not required when Items "D" are used.
D	2 each side of pile	2 in. x 4 in., hardwood, long enough to extend from floor to 5 in. above top of pile, per Sketch 2. Secure each to Items "B" and "E", at outer ends of pile, with three 20-D nails, two in Item "B" and one in Item "C." Place one additional Item "D" about at center of overlapping portion of 2 piles.
E	2 each Item "B"	2 in. x 4 in., hardwood, length about 10 in. Locate about 1 in. from pile or against Item "C" and secure to Items "B" with three 20-D nails.
F	1 each Item "D"	2 in. x 4 in., hardwood, length about 10 in. Locate edgewise and against Item "D" and secure to side of Items "B" and "E" with three 20-D nails.
G	1 each pair Items "D"	2 in. x 4 in., hardwood, length about equal to inside width of car. Locate about 1 in. above top of pile and secure to each Item "D" with three 20-D nails.
H	Individual ties. As required.	Wires or bands. A minimum of two ties per pile must be used. Draw taut but not too tight. Locate as far away from Items "B" as practicable. (See following table.)

Width of Pile	Height of Pile	No. 8 ga. wires	1 1/4 in. x .035 in. bands	2 in. x .050 in. bands
24 in. wide or less	12 in. high or less	1 each 4 ft. length of pile, or fraction thereof	1 each 8 ft. length of pile, or fraction thereof	1 each 16 ft. length of pile, or fraction thereof
	Over 12 in. high	1 each 2 ft. length of pile, or fraction thereof	1 each 4 ft. length of pile, or fraction thereof	1 each 8 ft length of pile, or fraction thereof
Over 24 in. to 48 in.	12 in. high or less	1 each 2 1/2 ft. length of pile, or fraction thereof	1 each 5 ft. length of pile, or fraction thereof	1 each 10 ft. length of pile, or fraction thereof
	Over 12 in. high	1 each 2 ft. length of pile, or fraction thereof	1 each 4 ft. length of pile, or fraction thereof	1 each 8 ft. length of pile, or fraction thereof
Over 48 in. wide	12 in. high or less	1 each 2 ft. length of pile, or fraction thereof	1 each 4 ft. length of pile, or fraction thereof	1 each 8 ft. length of pile, or fraction thereof
	Over 12 in. high	1 each 1 1/2 ft. length of pile, or fraction thereof	1 each 3 ft. length of pile, or fraction thereof	1 each 6 ft. length of pile, or fraction thereof

J As required. Protection angles, 20 gage, 4 in. wide, applied so as to prevent displacement. Items "D", "F" and "G" not required for piles 12 in. or less in height. Item "D", "F" and "G" not required for piles over 12 in. to 18 in. in height provided additional tie equal to strength of one 2 in. band (Item H) is used.

Items "B" to Items "J", inclusive, not required when total vacant space between piles and between piles and car sides, across car, does not exceed 8 in. The inside width of car may be reduced a maximum of 8 in. by the application of suitable wooden fillers, (minimum 2, maximum 6) located between each Item "B" and attached to each side of car, as follows:

For wood side cars—each shall consist of 2 pieces of 2 in. x 4 in., hardwood, length 2 in. greater than height of pile. Nail first piece to car side with four 20-D nails and second piece to first piece in a like manner.

For steel side cars—use one 4 in. x 4 in. or two 2 in. x 4 in., hardwood, and secure to car side with two 3/8 in. bolts, with washers, at each location.

If units vary in width, apply wood fillers secured so that they will not become displaced and so as to make size of piles uniform at the points where Items "H" and "J" are applied.

Narrow units may be placed side by side and tied together provided vertical separators, applied so as to prevent displacement, or top clamping pieces 1 in. thick, are used.

Where width of piles permit, they should be loaded side by side, in order to keep height of load as low as possible. 1 in. x 3 in. strips must be securely nailed to vertical separators, when used, to prevent displacement. Horizontal separators are prohibited.

When load extends about entire length of car and is lapped at center or staggered, maximum weight must not exceed marked capacity of car.

Units may overlap each other between truck centers, provided the end of each end pile is not more than one foot from end of car, and that the specified weight limitations in Rule 4 are not exceeded at overlapped portion of load. Extreme height of load, measured at any point must not exceed 30 inches from floor.

See General Rules 4, 5, 9, 14 and 15 for further details.

Sec. 2—Fig. 20

UNOILED STEEL PLATES AND SHEETS, CROSSWISE, SECURED WITH HIGH TENSION WIRES OR HIGH TENSION BANDS. HEIGHT OF PILES MUST NOT EXCEED 28 IN. ABOVE FLOOR, NOR WIDTH OF INDIVIDUAL UNITS—
GONDOLA CARS

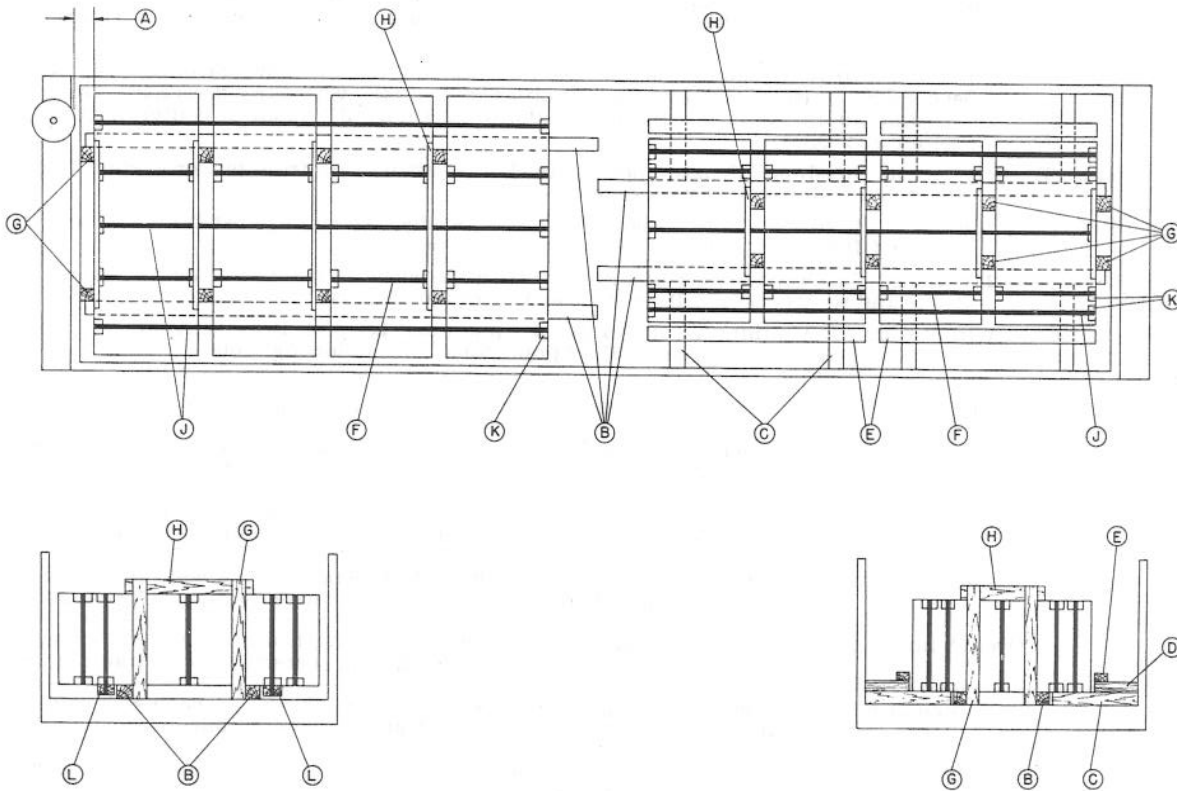

Item	No. of Pcs.	Description
A		Brake wheel clearance. See Fig. 2.
B	2 per pile or series of piles	2 in. x 4 in., hardwood. Must be long enough to extend 3 ft. beyond sides of single pile or series of piles, except when loaded full length of car. Substitute, if desired, 1 in. x 3 in., hardwood, when use of Items "C" or "L" is not required. Nail to floor with 20-D nails spaced about 18 in. apart when Items "C", "D", "E" or "L" are used.
O	To suit	2 in. x 4 in., hardwood, long enough to extend from side of car to Items "B". Not required when Items "L" are used, nor when total vacant space between piles and between piles and car sides, across car, does not exceed 8 in.
D	2 ea. Item "C"	2 in. x 4 in., hardwood, long enough to extend from about 1 in. from pile to car side, nailed to Item "C" with three 20-D nails.
E	As required.	2 in. x 4 in., hardwood, long enough to extend 2 in. beyond Items "D". Locate about 1 in. from load and nail to each Item "D" with three 20-D nails. If the vacant space across car exceeds 8 in. and the space between piles and sides of car does not permit application, other suitable fillers may be substituted for Items "E".

UNOILED STEEL PLATES AND SHEETS, CROSSWISE, SECURED WITH HIGH TENSION WIRES OR HIGH TENSION BANDS. HEIGHT OF PILES MUST NOT EXCEED 28 IN. ABOVE FLOOR, NOR WIDTH OF INDIVIDUAL UNITS—GONDOLA CARS

Item	No. of Pcs.	Description
F	Individual ties as required.	Wires or bands. Lengthwise of car, suitably spaced. Draw taut but not too tight.

Width of Pile	No. 8 ga. wire	1¼ in. x .035 in. bands	2 in. x .050 in. bands
24 in. or less.....	4	2	2
Over 24 in. wide.....	6	3	2

G	As required.	Suitable hardwood vertical separators, placed inside of, and adjacent to Items "B".
H	1 ea. pr. Items "G"	1 in. x 3 in., nailed to Items "G".
J	Overall Ties, As required.	Wires or bands. Lengthwise of car, suitably spaced. Draw taut but not too tight. Not required when load completely fills length of car.

Weight of pile	No. 8 ga. wire	1¼ in. x .035 in. bands	2 in. x .050 in. bands
25,000 lbs. or less.....	3	2	2
25,001 lbs. to 40,000 lbs.....	4	2	2
40,001 lbs. to 55,000 lbs.....	6	3	2
55,001 lbs. to 85,000 lbs.....	8	4	2

K	As required.	Protection angles, 20 gage, 4 in. wide, applied so as to prevent displacement.
L	2 ea. pile	1 in. x 3 in., or slightly thinner than Items "B", with ends about even with sides of piles. Locate both either inside or outside of and not more than 1 in. from Items "B". Secure to single pile by Items "F", or to series of piles by Items "J". Not required when Items "C" are used, nor when total vacant space between piles and between piles and car sides, across car, does not exceed 8 in.

If units vary in width, apply wood fillers secured so that they will not become displaced and so as to make size of pile uniform at the points where Items "F" and "J" are applied.

Narrow units may be placed side by side and tied together provided vertical separators applied so as to prevent displacement or top clamping pieces 1 in. thick are used.

See General Rules 4, 5, 9, 14 and 15 for further details.

Sec. 2—Fig. 21

UNOILED STEEL PLATES AND SHEETS, CROSSWISE (STAGGERED), SECURED WITH HIGH TENSION WIRES OR HIGH TENSION BANDS. HEIGHT OF PILES MUST NOT EXCEED 28 IN. ABOVE FLOOR AT CAR SIDES, NOR WIDTH OF INDIVIDUAL UNIT—GONDOLA CARS

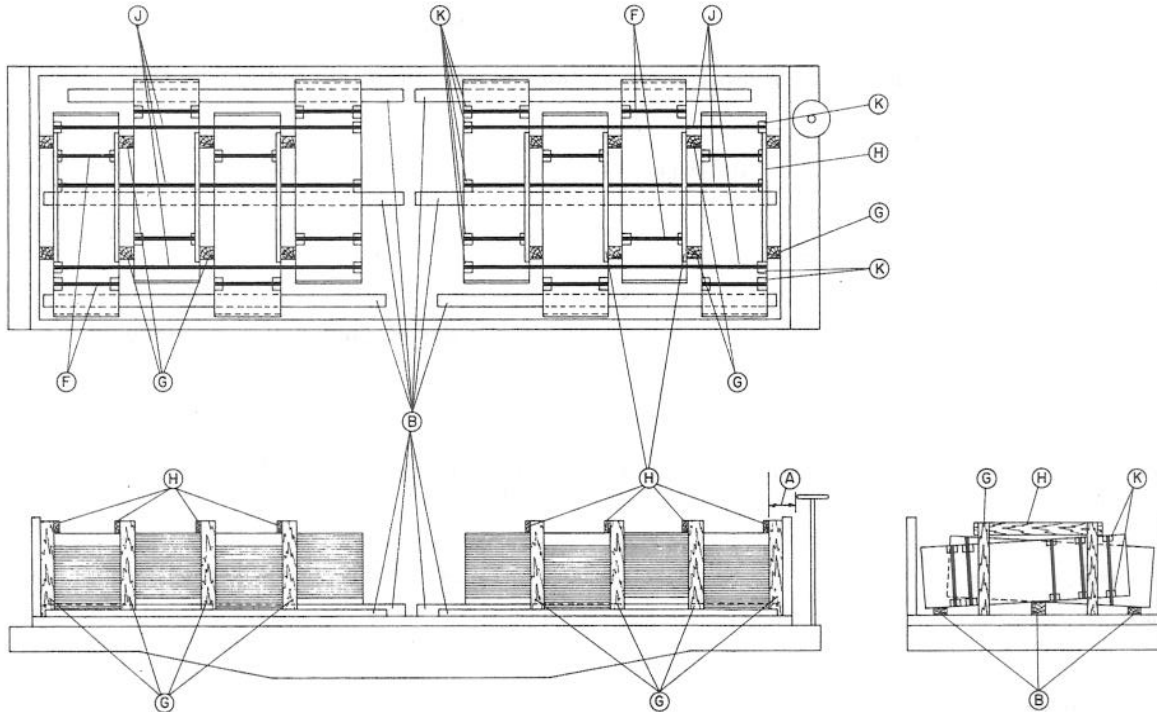

Item	No. of Pcs.	Description
A		Brake wheel clearance. See Fig. 2.
B	As required.	One 2 in. x 3 in., hardwood, located in center of car, and two 1 in. x 3 in., hardwood, one located approximately 6 in. from each side of car. Must be long enough to extend 3 ft. beyond sides of end piles, except when loaded full length of car. Center Item "B" must be 1 in. higher than side Items "B".
C		VACANT.
D		VACANT.
E		VACANT.
F	Individual ties. As required.	Wires or bands. Lengthwise of car, suitably spaced. Draw taut but not too tight.

Width of pile	No. 8 ga. wire	1 1/4 in. x .035 in. bands	2 in. x .050 in. bands
24 in. or less	4	2	2
Over 24 in. wide	6	3	2

G	As required.	Suitable hardwood vertical separators, placed between center and outside Items "B", as close to the ends of pile as practicable.
H	1 each pair Items "G"	1 in. x 3 in., nailed to Items "G".
J	Overall ties As required.	Wires or bands. Lengthwise of car, suitably spaced. Draw taut but not too tight. Not required when load completely fills length of car.

Weight of pile	No. 8 ga. wires	1 1/4 in. x .035 in. bands	2 in. x .050 in. bands
25,000 lbs. or less	3	2	2
25,001 lbs. to 40,000 lbs.	4	2	2
40,001 lbs. to 55,000 lbs.	6	3	2
55,001 lbs. to 85,000 lbs.	8	4	2

K As required. Protection angles, 20 gage, 4 in. wide, applied so as to prevent displacement.

If units vary in width, apply wood fillers secured so that they will not become displaced and so as to make size of pile uniform at the points where Items "F" and "J" are applied.

Narrow units may be placed side by side and tied together provided vertical separators applied so as to prevent displacement, or top clamping pieces 1 in. thick, are used.

Horizontal separators are prohibited.

See General Rules 4, 5, 9, 14 and 15 for further details.

UNOILED STEEL PLATES OR SHEETS OVER 1/8 IN. THICK, LENGTHWISE—GONDOLA CARS

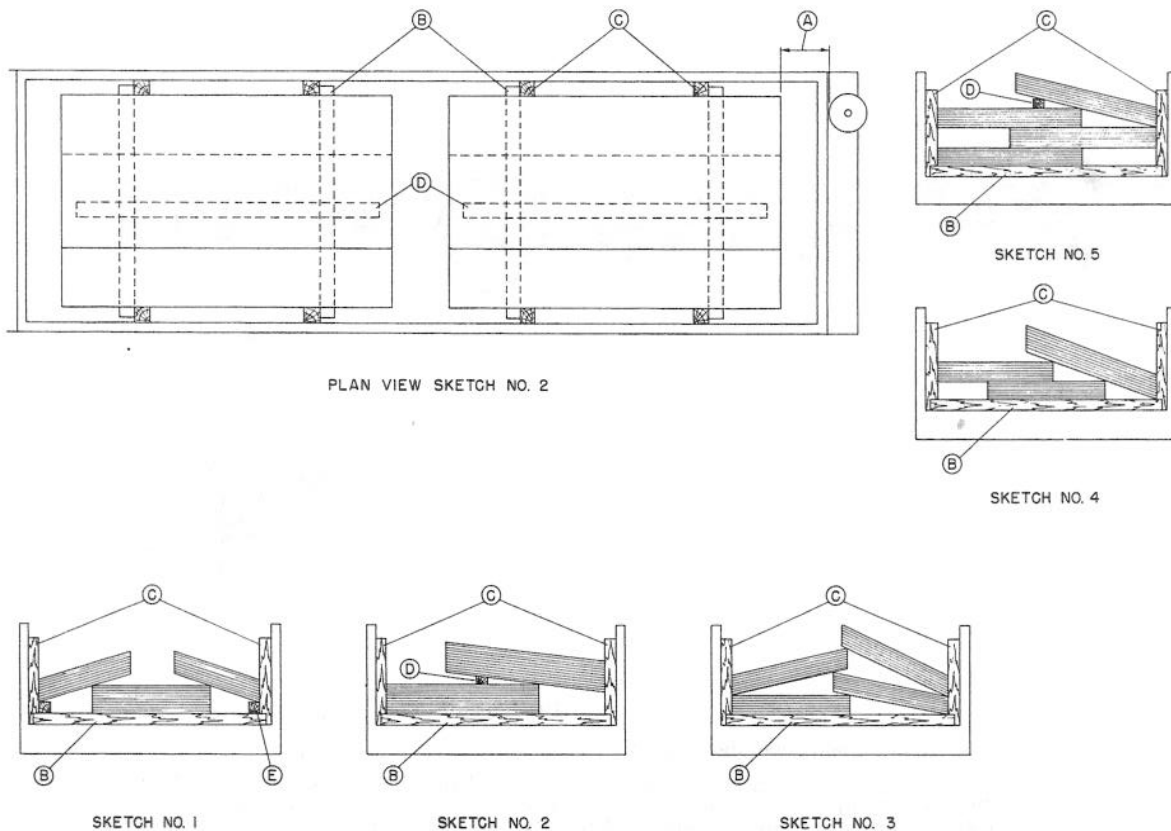

Item	No. of Pcs.	Description
A		Brake wheel clearance. See Fig. 2.
B	As required.	2 in. x 4 in., length about 2 in. less than width of car. Use optional.
C	2 per pile each side of car	Wood, dimensions to suit. Use optional.
D	As required. Sketches 2 and 5	2 in. x 4 in., length to suit. Locate so as to incline top lift towards side of car.
E	2 per pile. Sketch 1	Wood, dimensions to suit. Use optional.

When loaded as per Sketch 1, the height of center portion above Items "B" must not be more than 10 in. and of a width that will place over 50% of weight of side lift below overlapping contact point. One side of each side portion must contact Items "C" or side of car. The height of complete pile measured at point where top portion rests on center portion must not exceed 23 in. above Items "B". 4 in. x 4 in. pieces, length to suit, may be substituted for center pile of steel. Locate one about 2 ft. from each end of side portions, space intermediate pieces not more than 8 ft. apart. Secure to Items "B" or wood floor with four 30-D nails in each and to steel floors with two 5/8 in. dia. bolts in each.

When loaded as per Sketch 2, the weight of plates in each portion must be equal and wide enough to permit the top portion to overlap the bottom portion about 2/3 of its width, with one side of each portion contacting Item "C" or side of car. The height of complete pile, measured at point where top portion rests on bottom portion, must not exceed 23 in. above Items "B".

When loaded as per Sketch 3, the weight of plates in each portion must be equal and wide enough to permit the top portion to overlap the bottom portion not less than 2 in. with one side of each portion contacting Items "C", or side of car. The height of complete pile, measured at Items "C" or sides of car, must not exceed 12 in. above Items "B".

When loaded as per Sketch 4, the height of pile, measured at a point where top portion rests on bottom portion, nearest side of car, must not exceed 23 in. above Items "B".

When loaded per Sketch 5, the height of pile, measured at a point where top portion rests on the one immediately below, nearest to side of car, must not exceed 23 in.

See General Rules 4, 5, 9, 14 and 15 for further details.

LARGE GIRDERS, STRUCTURAL METAL SHAPES, PLATES, ETC., OVERHANGING ONE END OF CAR—FLAT OR GONDOLA CARS

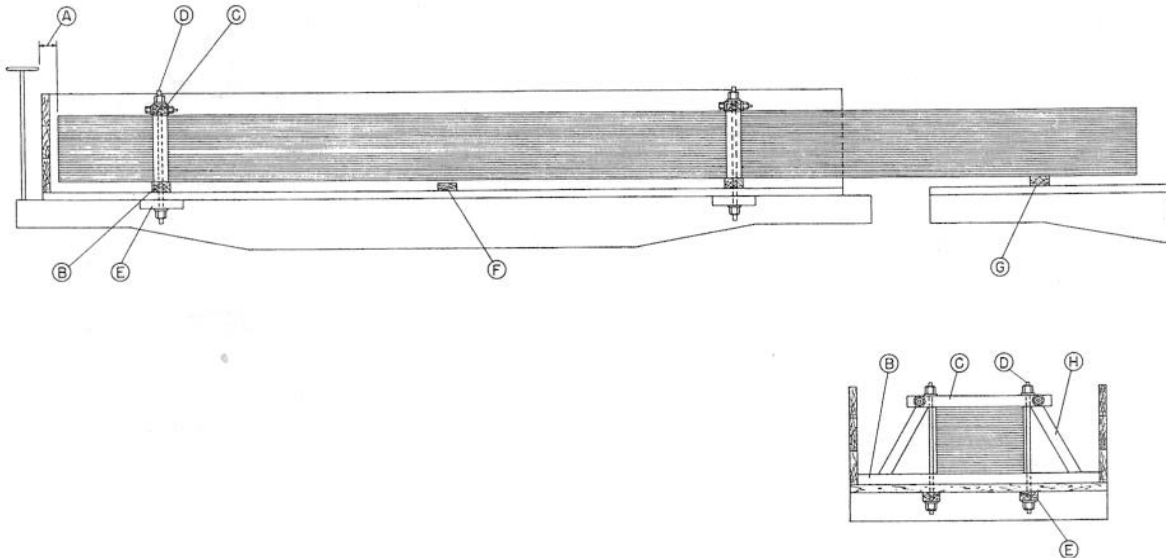

Item	No. of Pcs.	Description
A		Brake Wheel Clearance. See Fig. 2.
B	2	8 in. wide, hardwood, high enough to keep load 4 in. above floor and/or end gate of idler car. The length must not be less than the width of car except that it may extend 12 in. beyond each side of load not exceeding 25,000 lb. For rigid material not exceeding one-half load weight limit, and flexible material, it may be placed 12 in. from center line of bolster toward end of car. To prevent flanges, less than 1 in. thick, on structural material weighing over 20,000 lbs. per bearing piece, from cutting into bearing pieces, blocks, thicker than the depth of flanges, must be placed underneath the bottom pieces of material. When only one is used at each end of material, its width must be equal to the width of Item "B", and long enough to fill about 75 percent of space between flanges. It must be secured to prevent displacement, except when 4 ft. long and placed lengthwise of car. When two are used, the width of each must not be less than its height. Each must be 4 ft. long and located close to flange and lengthwise of car. When material is 12 in. wide, or more, place the block, or blocks, under each outside piece only, and when material is less than 12 in. wide, they must be placed under the two outside pieces each side of load.
C	2	4 in. x 6 in., hardwood. Place one bolt, $\frac{1}{2}$ in. dia., crosswise, with washers, at each end to prevent splitting.
D	4	1 in. dia., with washers.
E	4	4 in. x 4 in. x 18 in., hardwood, or $\frac{1}{2}$ in. x 4 in. x 18 in. plate.
F	1	8 in. wide, height 2 in. less than Items "B", hardwood. Required only when material is liable to damage by permanent deflection.
G	1	8 in. wide, hardwood, length equal to width of car, protected by $\frac{1}{4}$ in. x 6 in. steel plate, and bolted through Item "G", and floor with two $\frac{3}{4}$ in. dia. countersunk head bolts. When sliding-piece is located between end of car and body bolster, the weight on same must not exceed ten percent of load weight limit. Not required when material is rigid enough to maintain clearance as per Item "B".
H	4	4 in. x 6 in., hardwood, on loads 2 ft. high or over, toe-nailed to Items "B" and "C" with three 40-D nails at each location. Not required for structural material 24 in. wide or more, unless the height exceeds the width of the individual pile in the load.

When large girders, etc., are loaded one on top of the other, same must be separated by 2 in. x 8 in. hardwood, long enough to extend beyond sides of load, located near Items "B", and over Item "F", if latter is used.

For flat cars add one binder to overhang, above couplers, consisting of 2 pcs. 4 in. x 6 in., hardwood, with $\frac{1}{2}$ in. split bolts, secured with two 1 in. dia. rods. If desired, two 2 in. x .050 high tension bands, located as close together as possible may be substituted for this binder.

Items "C", "D", "E" and "H" not required at closed end of gondola car when substituted with two 2 in. x .050 in. high tension bands, located as close together as possible, with sharp corners protected, and side blocking used when the side clearance exceeds 8 in.

See General Rules 4, 5, 6, 8, 9, 10, 12, 13, 14, 15, 16 and 18 for further details.

THIS PAGE WAS LEFT BLANK INTENTIONALLY

FLAT ROLLED STEEL LESS THAN 1/4 IN. THICK, WITH HIGH TENSION BANDS OR HIGH TENSION WIRES, STRENGTH 2,000 POUNDS EACH, CROSSWISE—GONDOLA CARS

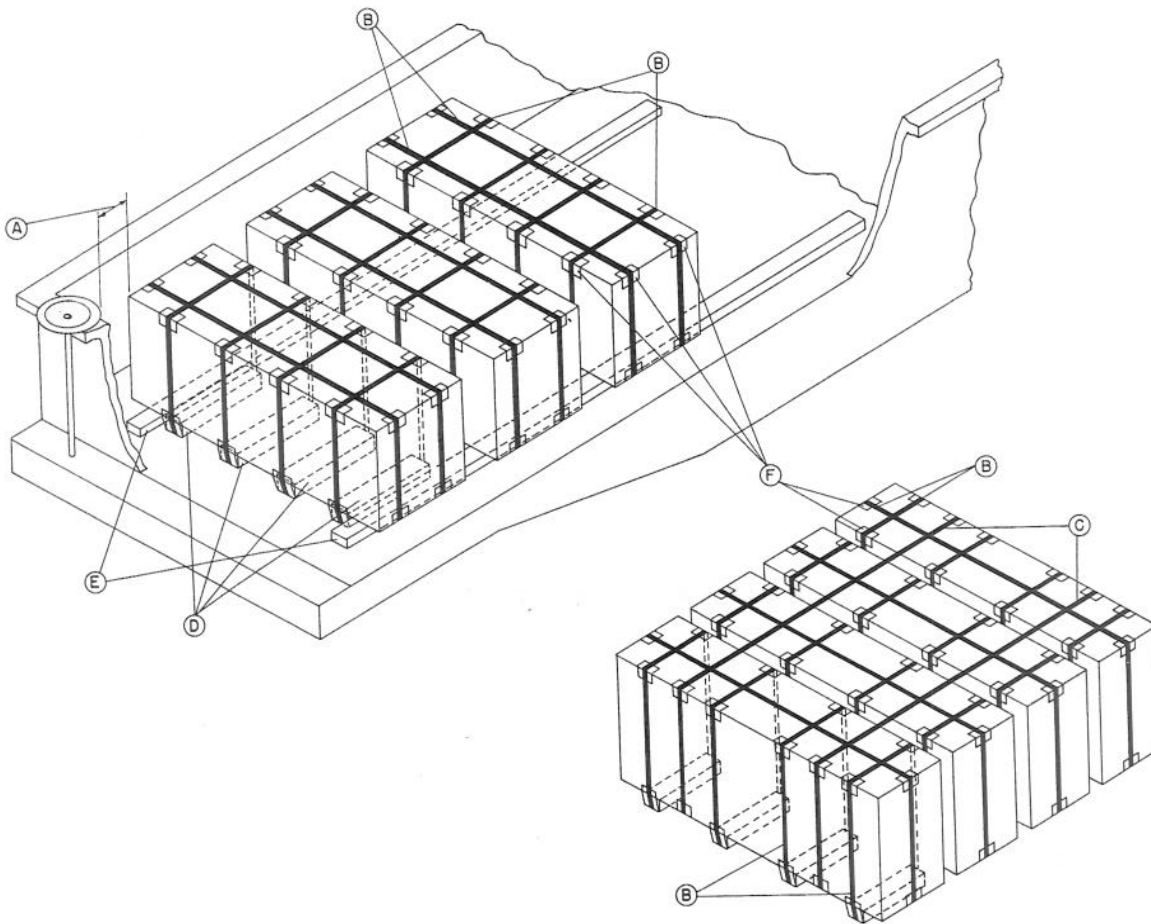

Item	No. of Pcs.	Description
A		Brake wheel clearance. See Fig. 2.
B	Individual Ties. As required.	Bands or Wires. Draw taut but not too tight.

OTHER THAN OILED OR HIGHLY FINISHED

	Wt. of Pile	3,000 lbs. or less		Over 3,000 lbs. to 15,000 lbs.		Over 15,000 lbs. to 20,000 lbs.		Over 20,000 lbs. to 30,000 lbs.	
		14 in. or less	Over 14 in.	14 in. or less	Over 14 in.	14 in. or less	Over 14 in.	14 in. or less	Over 14 in.
Lengthwise of Car, together with Crosswise Ties.	Total Ld. Strength of Ties (lbs.)	4000	4000	6000	8000	8000	10000	10000	12000
Crosswise of Car, together with Lengthwise Ties.		0	2000	0	2000	2000	4000	4000	6000
Lengthwise of Car, without Other Ties.		4000	6000	6000	10000	10000	14000	14000	18000

**FLAT ROLLED STEEL LESS THAN ¼ IN. THICK, WITH HIGH TENSION BANDS OR HIGH TENSION WIRES,
STRENGTH 2,000 POUNDS EACH, CROSSWISE—GONDOLA CARS**

OILED OR HIGHLY FINISHED

	Wt. of Pile	3,000 lbs. or less		Over 3,000 lbs. to 15,000 lbs.		Over 15,000 lbs. to 20,000 lbs.		Over 20,000 lbs. to 30,000 lbs.	
		Width of Pile	14 in. or less	Over 14 in.	14 in. or less	Over 14 in.	14 in. or less	Over 14 in.	14 in. or less
Lengthwise of Car.	Total Ld. Strength of Ties (lbs.)	4000	4000	6000	10000	10000	12000	12000	14000
Crosswise of Car.		2000	2000	2000	2000	4000	4000	6000	6000

Item	No. of Pcs.	Description
C	Overall Ties 4 per unit	Bands or wires, lengthwise of car. Draw taut but not too tight. Required only when a series of piles are tied into a unit.
D	2 per pile	2 in. x 3 in., hardwood, beveled ends, not more than 2 in. shorter than width of pile, secured by Items "B", lengthwise of car.
E	As required. Minimum 2 per pile or series of piles	Guide strips, 1 in. x 3 in., or thinner than Items "D". Place on floor, both to be inside or outside of, and not more than 1 in. from Items "D". Must be continuous and extend not less than 4 ft. beyond side of pile. Secure to wood floors with 20-D nails spaced about 18 in. apart and to steel floors with ¾ in. x 2½ in. bolts, with washers, or ¼ in. x 2½ in. self-threading metal drive screws located not more than 6 in. from each end of each guide strip and not more than 4 ft. apart. Not required when the total vacant space across car between piles and between the load and car sides does not exceed 8 in.
F	As required.	Protection angles, 20 gage, 4 in. wide, applied so as to prevent displacement.

When single pile weighs over 30,000 lbs., add one additional lengthwise and one additional crosswise tie for each additional 5,000 lbs. or less.

Items "B" and "C" of greater strength than 2,000 lbs. may be used, provided a minimum of two lengthwise of car are used and one crosswise of car is used, where specified.

Height of piles must not exceed ¾ their base, nor 2 in. below top of car side.

Separators may be used, but they must be secured to prevent displacement.

If sheets, vary in width or length, apply wood fillers secured so that they will not become displaced, and so as to make size of pile uniform at the points where lengthwise and crosswise Items "B" and "C" are applied.

See General Rules, 4, 5, 9, 14 and 15 for further details.

FLAT ROLLED STEEL LESS THAN ¼ IN. THICK, IN BUNDLES, WITHOUT GUIDE STRIPS, WITH HIGH TENSION BANDS OR HIGH TENSION WIRES, LENGTHWISE—GONDOLA CARS WITH STEEL FLOORS.

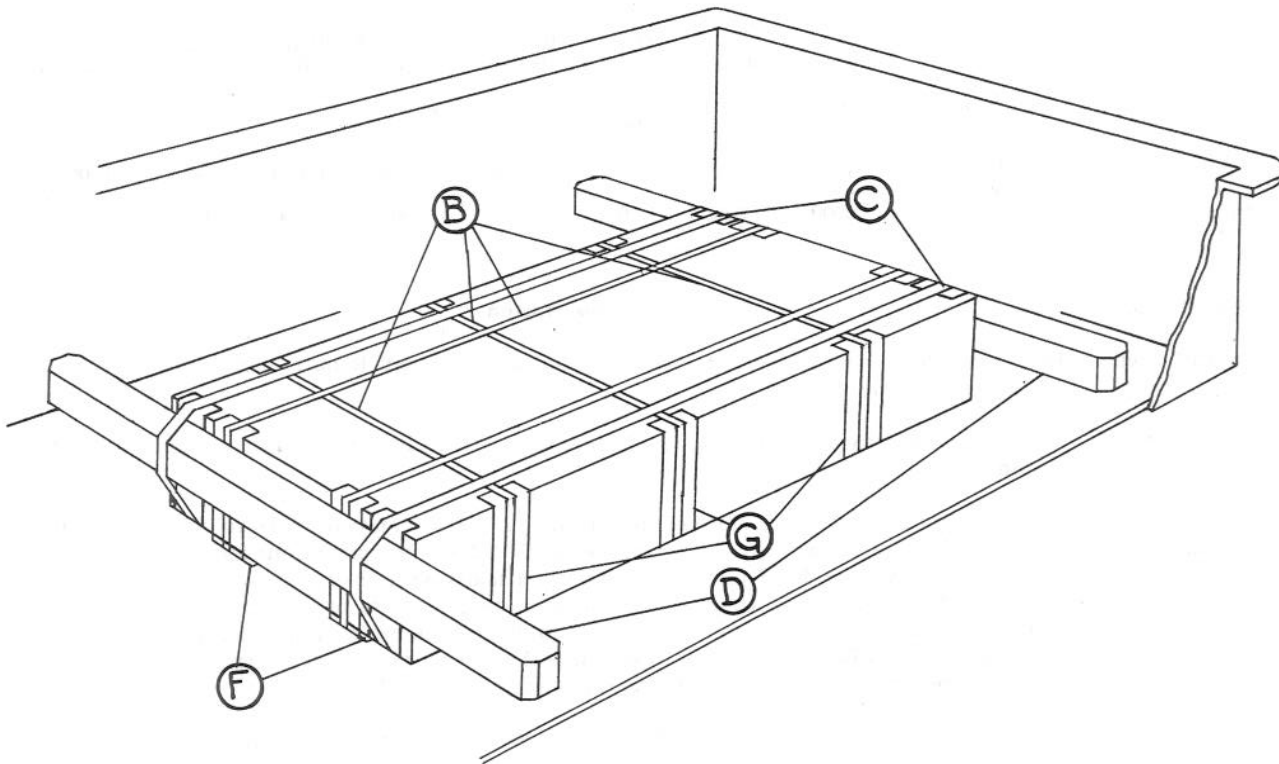

Item	No. of Pcs.	Description
A		Brake wheel clearance. See Fig. 2.
B	As required.	Individual Ties, Bands or Wires.

OTHER THAN OILED OR HIGHLY FINISHED

	Wt. of Pile	3,000 lbs. or less	Over 3,000 lbs. to 15,000 lbs.	Over 15,000 lbs. to 20,000 lbs.	Over 20,000 lbs. to 30,000 lbs.
Lengthwise of Car, Together with Crosswise Ties.	Total Load Strength of Ties (lbs.)	4,000	4,000	6,000	8,000
Crosswise of Car Together with Lengthwise Ties.		4,000	6,000	8,000	12,000
Crosswise of Car, and Bundle Only.		8,000	10,000	16,000	24,000

OILED OR HIGHLY FINISHED

	Wt. of Pile	10,000 lbs. or less	Over 10,000 lbs. to 20,000 lbs.	Over 20,000 lbs. to 30,000 lbs.
Lengthwise of Car	Total Ld. Strength of Ties (lbs.)	4,000	6,000	8,000
Crosswise of Car		6,000	12,000	16,000

- C 3 per pile or series of piles 2 in. x .050 in. bands or ties of equivalent strength. Pass over Items "D".
- D 2 per pile 4 in. x 4 in., hardwood, length 2 in. less than width of car. Bevel front and back corners on each end about 1 in., as shown. Locate about 2 in. from top of pile and secure with Items "C".
- E VACANT.
- F 2 per pile 2 in. x 3 in., hardwood, beveled ends, not more than 2 in. shorter than pile. Secure by lengthwise Items "B".
- G As required. Protection angles, 20 ga., 4 in. wide, applied so as to prevent displacement.

Height of pile must not exceed ¼ its base or 2 in. below top of car sides.

Separators may be used, but they must be secured to prevent displacement.

If sheets vary in width or length, apply wood fillers secured so that they will not become displaced and so as to make size of pile uniform at the points where lengthwise and crosswise Items "B" are applied.

See General Rules, 4, 5, 9, 14 and 15 for further details.

THIS PAGE WAS LEFT BLANK INTENTIONALLY

FLAT ROLLED STEEL, LESS THAN 1/4 IN. THICK, IN ONE OR MORE LAYERS, WITH HIGH TENSION BANDS OR HIGH TENSION WIRES, STRENGTH 2,000 LBS. EACH—GONDOLA CARS WITH WOOD FLOORS

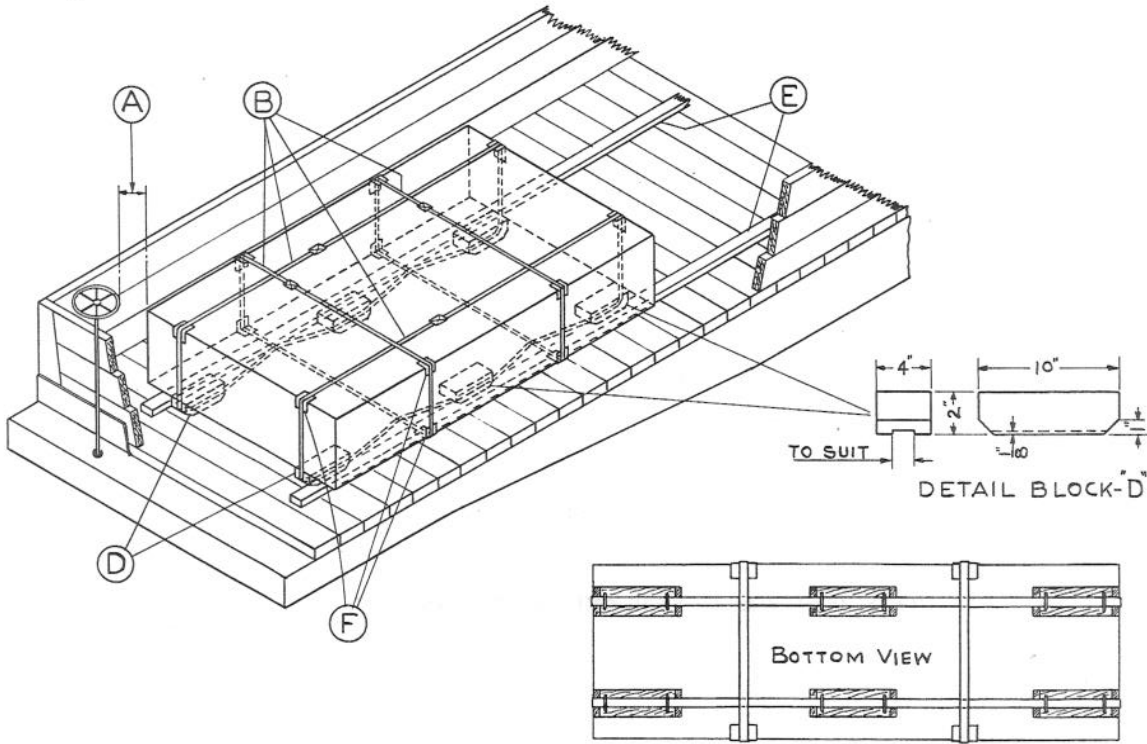

Item	No. of Pcs.	Description
A		Brake wheel clearance. See Fig. 2.
B	As required.	Individual ties, bands or wires, minimum two lengthwise and two crosswise.

OTHER THAN OILED OR HIGHLY FINISHED

	Wt. of Pile	3,000 lbs. or less	Over 3,000 lbs. to 15,000 lbs.	Over 15,000 lbs. to 20,000 lbs.	Over 20,000 lbs. to 30,000 lbs.
Lengthwise of car.....	Total Ld. Strength of Ties (lbs.)	4,000	4,000	6,000	8,000
Crosswise of car.....		4,000	6,000	8,000	12,000

OILED OR HIGHLY FINISHED

	Wt. of Pile	10,000 lbs. or less	Over 10,000 lbs. to 20,000 lbs.	Over 20,000 lbs. to 30,000 lbs.
Lengthwise of car.....	Total Ld. Strength of Ties (lbs.)	4,000	6,000	8,000
Crosswise of car.....		6,000	12,000	16,000

Lengthwise Items "B" nearest sides of pile to be stapled to each Item "D" with two staples.

O	Overall Ties. As required.	Bands or Wires. Two or more packages per pile. Draw taut but not too tight.
---	----------------------------	---

FLAT ROLLED STEEL, LESS THAN 1/4 IN. THICK, IN ONE OR MORE LAYERS, WITH HIGH TENSION BANDS OR HIGH TENSION WIRES, STRENGTH 2,000 LBS. EACH—GONDOLA CARS WITH WOOD FLOORS

PLAIN, OILED OR HIGHLY FINISHED

	Wt. of Pile	10,000 lbs. or less	Over 10,000 lbs. to 20,000 lbs.	Over 20,000 lbs. to 30,000 lbs.
Lengthwise of car	Total Ld. Strength of Ties (lbs.)	8,000	12,000	16,000

Item	No. of Pcs.	Description
D	Pile 7 ft. long or less, 4. Pile over 7 ft. to 10 ft., 6. Pile over 10 ft. to 15 ft., 8. Pile over 15 ft., 10.	2 in. x 4 in. x 10 in., hardwood. Bevel each about 1 in. at both ends, gain out 1/8 in. deep on bottom of each for bands or wires, per Sketch 1, and locate about 4 in. from each side of pile. End blocks must be flush with each end of pile, with intermediate blocks equally spaced. Locate crosswise ties under bottom of and over top of lengthwise ties.
E	2 per pile	Guide strips, 1 in. x 3 in. Place on floor, both to be inside or outside of, and not more than 1 in. from Items "D". Must be continuous and extend not less than 4 ft. beyond ends of pile. Nail to floor with 20-D nails spaced about 18 in. apart. Not required when the total vacant space across car between piles and between the load and car sides does not exceed 8 in.
F	As required.	Protection angles, 20 gage, 4 in. wide, applied so as to prevent displacement.

When single pile weighs over 30,000 lbs., add one additional lengthwise and one additional crosswise tie for each additional 5,000 lbs. or less.

At least one crosswise Item "B" must encircle lengthwise Items "B" between Items "D" as shown.

If sheets vary in width or length, apply wood fillers secured so that they will not become displaced, and so as to make size of pile uniform at the points where lengthwise and crosswise Items "B" are applied.

See General Rules 4, 5, 9, 14 and 15 for further details.

Sec. 2—Fig. 27

FLAT ROLLED STEEL LESS THAN 1/4 IN. IN THICKNESS, IN BUNDLES, WITH HIGH TENSION BANDS OR HIGH TENSION WIRES, STRENGTH 2,000 LBS. EACH, LENGTHWISE—GONDOLA CARS

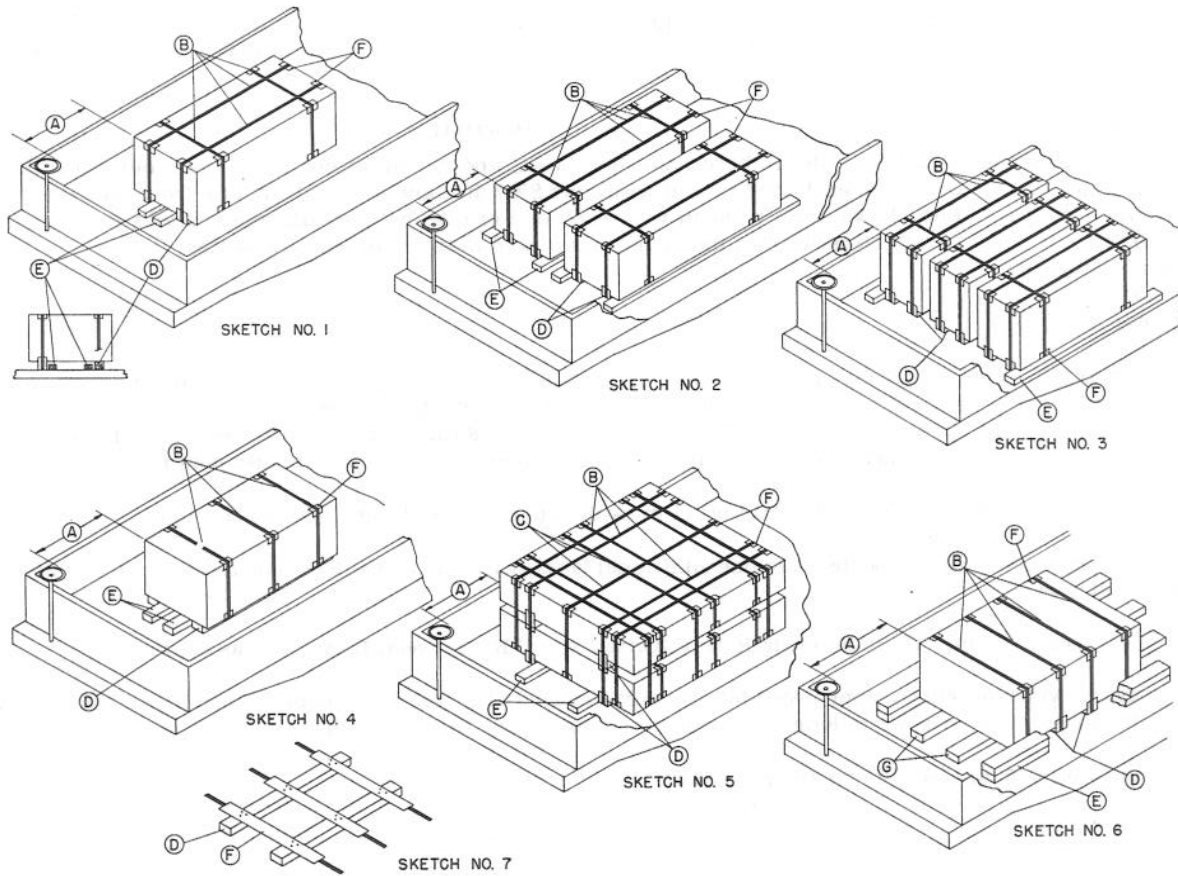

Item	No. of Pcs.	Description
A		Brake wheel clearance. See Fig. 2.
B	As required.	Individual Ties, Bands or Wires.

OTHER THAN OILED OR HIGHLY FINISHED

	Wt. of Pile	3,000 lbs. or less	Over 3,000 lbs. to 15,000 lbs.	Over 15,000 lbs. to 20,000 lbs.	Over 20,000 lbs. to 30,000 lbs.
Lengthwise of Car, Together With Crosswise Ties.	Total Ld. Strength of Ties (lbs.)	4,000	4,000	6,000	8,000
Crosswise of Car, Together With Lengthwise Ties.		4,000	6,000	8,000	12,000
Crosswise of Car and Bundle Only.		8,000	10,000	16,000	24,000

FLAT ROLLED STEEL LESS THAN ¼ IN. IN THICKNESS, IN BUNDLES, WITH HIGH TENSION BANDS OR HIGH TENSION WIRES, STRENGTH 2,000 LBS. EACH, LENGTHWISE—GONDOLA CARS

Item	No. of Pcs.	Description	OILED OR HIGHLY FINISHED		
			Wt. of Pile	10,000 lbs. or less	Over 10,000 lbs. to 20,000 lbs.
Lengthwise of Car.		Total Ld. Strength of Ties (lbs.)	4,000	6,000	8,000
Crosswise of car.			6,000	12,000	16,000

C As required. Overall Ties. Bands or Wires. Two or more packages per pile. Draw taut but not too tight. A minimum of two lengthwise and two crosswise ties must be used.

PLAIN, OILED OR HIGHLY FINISHED

	Wt. of Pile	10,000 lbs. or less	Over 10,000 lbs. to 20,000 lbs.	Over 20,000 lbs. to 30,000 lbs.
Crosswise of Car.		4,000	6,000	8,000
Lengthwise of Car.		8,000	12,000	16,000

D Sketches 1, 2, 3, 4, 5 and 7, 2 per pile. 2 in. x 3 in., hardwood, beveled ends, not more than 2 in. shorter than pile. Secure by lengthwise Items "B". Apply as per Sketch 7 when only crosswise Items "B" are used. Crosswise pieces, if used underneath pile, must rest on lengthwise skids, and be tied into pile.

Sketch 6, as required. 2 in. x 3 in., hardwood, full width of pile. Secure by crosswise Items "B".

E Sketches 1, 2, 3, 4 and 5, 1 ea. bottom Item "D". Guide strips, 1 in. x 3 in., or thinner than Items "D". Locate both either inside or outside of, and not more than 1 in. from Items "D". Must be continuous and extend not less than 4 ft. beyond ends of pile. Secure to wood floors with 20-D nails spaced about 18 in. apart and to steel floors with ⅜ in. dia. bolts, with washers, or ¼ in. dia. self-threading metal drive screws, or ⅝ in. dia. hardened steel nails located not more than 6 in. from each end of each guide strip and not more than 4 ft. apart.

Sketch 6, 2. Each to consist of two pieces 2 in. x 4 in., hardwood. Locate not more than 1 in. from pile. Must be continuous and extend not less than 4 ft. beyond ends of pile. Secure lower piece with 20-D nails spaced about 18 in. apart and top piece to one below in like manner.

Not required when the total vacant space across car between piles and between the load and car sides does not exceed 8 in.

F As required. Protection angles, 20 gage, 4 in. wide, applied so as to prevent displacement.

G Sketch 6, 2 per pile. 1 in. x 3 in., hardwood. Must be continuous and extend not less than 4 ft. beyond ends of pile. Locate about one-fourth width of pile from each side and secure with 10-D nails spaced about 18 in. apart.

When single pile weighs over 30,000 lbs., add one additional lengthwise and one additional crosswise tie for each additional 5,000 lbs. or less.

When loaded as per Sketches 1, 2, 3 and 5, use not less than 2 crosswise and 2 lengthwise ties. When loaded as per Sketches 4 and 6, use not less than two ties, crosswise of car and bundle.

Height of piles must not exceed ¾ their base or 2 in. below top of car side.

Separators may be used, but they must be secured to prevent displacement.

If sheets vary in width or length, apply wood fillers secured so that they will not become displaced, and so as to make size of pile uniform at the points where lengthwise and crosswise Items "B" are applied.

See General Rules 4, 5, 9, 14 and 15 for further details.

Sec. 2—Fig. 28

FLAT ROLLED STEEL LESS THAN $\frac{1}{4}$ IN. IN THICKNESS, IN BUNDLES, WITH HIGH TENSION BANDS OR HIGH TENSION WIRES, STRENGTH 2,000 LBS. EACH, LENGTHWISE—GONDOLA CARS WITH STEEL FLOORS

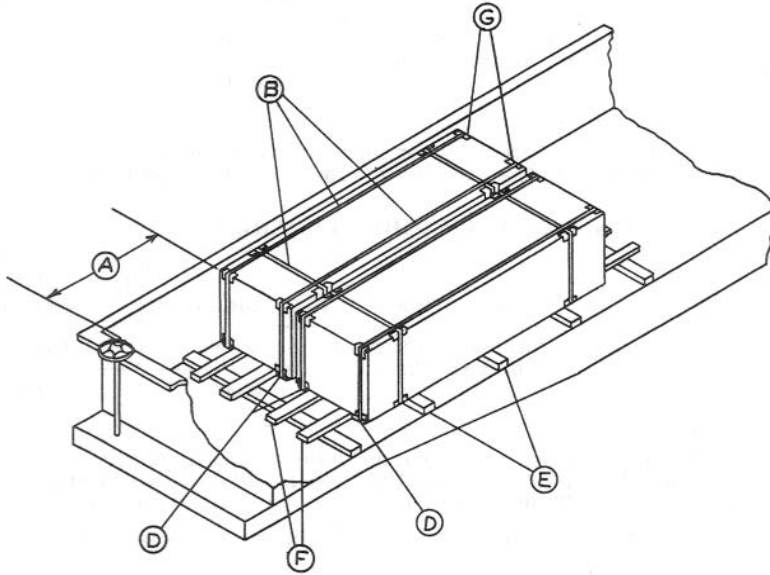

SKETCH NO. -1

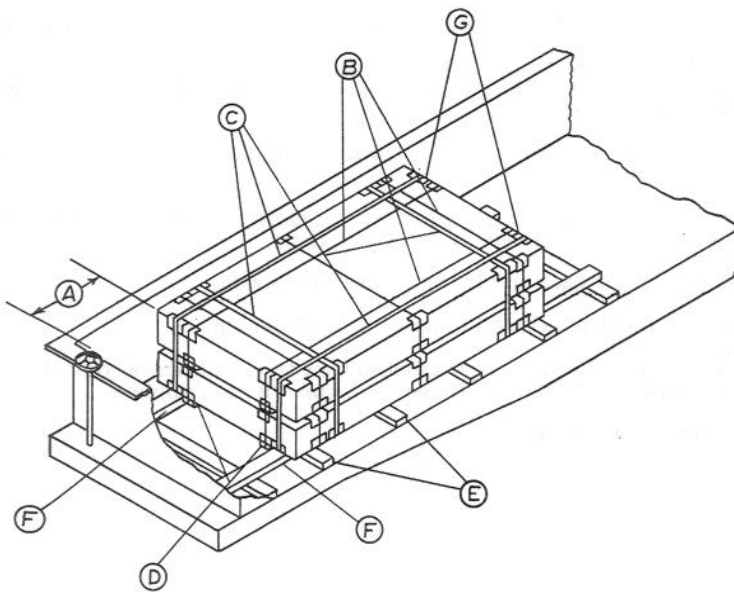

SKETCH NO. -2

Sec. 2—Fig. 28

FLAT ROLLED STEEL LESS THAN ¼ IN. IN THICKNESS, IN BUNDLES, WITH HIGH TENSION BANDS OR HIGH TENSION WIRES, STRENGTH 2,000 LBS. EACH, LENGTHWISE—GONDOLA CARS WITH STEEL FLOORS

Item	No. of Pcs.	Description
A		Brake wheel clearance. See Fig. 2.
B	As required.	Individual Ties, Bands or Wires. A minimum of two lengthwise and two crosswise ties must be used.

OTHER THAN OILED OR HIGHLY FINISHED

	Wt. of Pile	3,000 lbs. or less	Over 3,000 lbs. to 15,000 lbs.	Over 15,000 lbs. to 20,000 lbs.	Over 20,000 lbs. to 30,000 lbs.
Lengthwise of Car, Together With Crosswise Ties.	Total Ld. Strength of Ties (lbs.)	4,000	4,000	6,000	8,000
Crosswise of Car, Together With Lengthwise Ties.		4,000	6,000	8,000	12,000
Crosswise of Car and Bundle Only		8,000	10,000	16,000	24,000

OILED OR HIGHLY FINISHED

	Wt. of Pile	10,000 lbs. or less	Over 10,000 lbs. to 20,000 lbs.	Over 20,000 lbs. to 30,000 lbs.
Lengthwise of Car.	Total Ld. Strength of Ties (lbs.)	4,000	6,000	8,000
Crosswise of Car.		6,000	12,000	16,000

- C As required. Overall Ties, Bands or Wires. Two or more packages per pile. Draw taut but not too tight. A minimum of two lengthwise and two crosswise ties must be used.

PLAIN, OILED OR HIGHLY FINISHED

	Wt. of Pile	10,000 lbs. or less	Over 10,000 lbs. to 20,000 lbs.	Over 20,000 lbs. to 30,000 lbs.
Crosswise of Car.	Total Ld. Strength of Ties (Lbs.)	4,000	6,000	8,000
Lengthwise of Car.		8,000	12,000	16,000

- D 2 per pile. 2 in. x 3 in., hardwood, beveled ends, not more than 2 in. shorter than pile. Secure by lengthwise Items "B"
- E 1 to every 3 ft. Hardwood, 2 in. x 4 in., length equal to width of car.
- F 2 ea. bundle. Guide strips, 1 in. x 3 in. or thinner than Items "D". Locate both either inside or outside of, and not more than 1 in. from Items "D". Must be continuous and extend not less than 4 ft. beyond ends of pile. Secure to Items "E" at each location with three 20-d nails.
- G As required. Protection angles, 20 gage, 4 in. wide, applied so as to prevent displacement.

When single pile weighs over 30,000 lbs., add one additional lengthwise and one additional crosswise tie for each additional 5,000 lbs. or less.

Height of piles must not exceed ¾ their base or 2 in. below top of car side.

Separators may be used, but they must be secured to prevent displacement.

If sheets vary in width or length, apply wood fillers secured so that they will not become displaced, and so as to make size of pile uniform at the points where lengthwise and crosswise Items "B" are applied.

See General Rules 4, 5, 9, 14 and 15 for further details.

Sec. 2—Fig. 29

HEAVY COILS OF FLAT STEEL OVER 30 IN. WIDE, OVER 7500 LBS. PER COIL ON SKIDS, SECURED WITH 1¼ IN. X .035 IN. HIGH TENSION BANDS—GONDOLA CARS

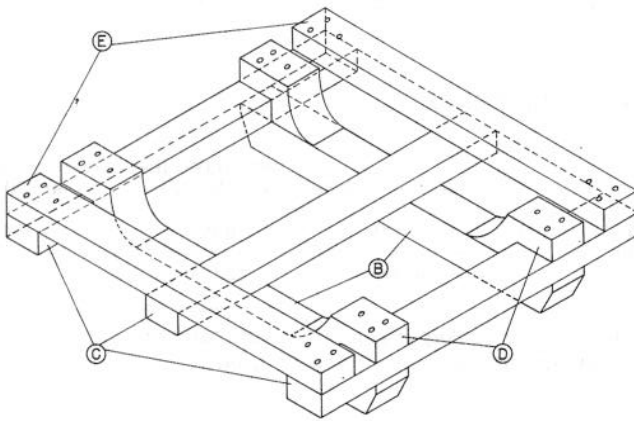
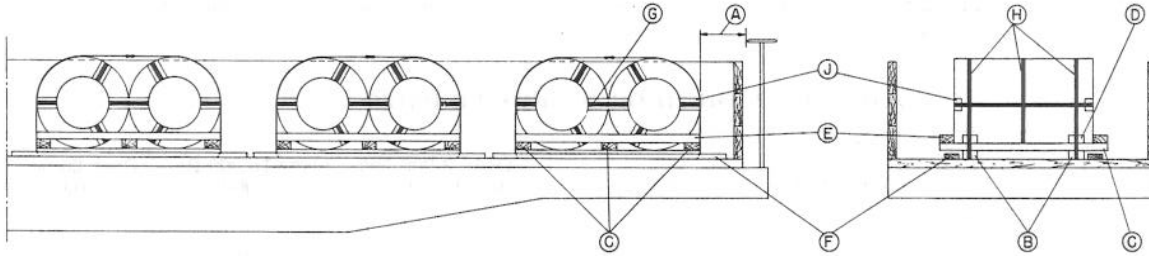

Item	No. of Pcs.	Description
A		Brake wheel clearance. See Fig. 2.
B	2 ea. unit	4 in. x 4 in., hardwood, length equal to length of unit, beveled as shown. Locate from 1 in. to 4 in. from outside edge of coils.
C	ea. unit	2 in. x 4 in., hardwood, long enough to apply Items "E". Secure to Items "B" with three 20-D nails at each point of contact.
D	2 ea. Item "B"	4 in. x 4 in., hardwood. Notch to fit Items "C", radius to fit outside contour of coil. Secure to Items "C" with three 20-D nails.
E	2 ea. unit	2 in. x 3 in., hardwood, length to suit. Secure to Items "C" with three 20-D nails at each end.
F	2 ea. unit	2 in. x 3 in., must extend at least 2 ft. beyond each end of unit. Locate on floor about 1 in. outside Items "B". Secure with 20-D nails.
G	1 ea. 2 coil unit	Band. Place through cores of coils.
H	Unit weighing 40,000 Lbs. or less; 3. Unit weighing over 40,000 Lbs.; 4.	Bands. Place one band around each skid and coils, and one or two as required around coils only.
J	To suit	Protection angles, 20 ga., 4 in. wide, applied so as to prevent displacement.

See General Rules 4, 5, 9, 14 and 15 for further details.

HEAVY COILS OF FLAT STEEL 55 IN. AND OVER IN DIAMETER ON SKIDS, SECURED WITH HIGH TENSION BANDS
—GONDOLA CARS

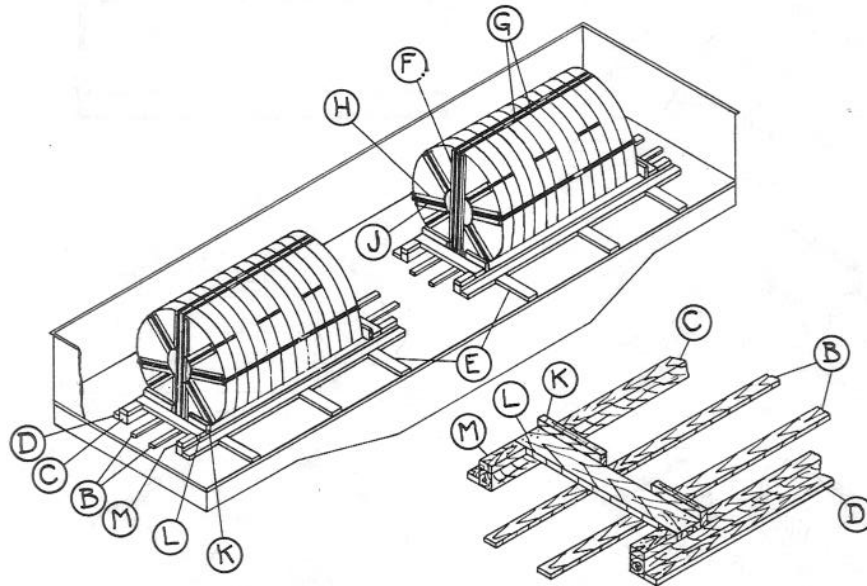

Item	No. of Pcs.	Description
A		Brake wheel clearance. See Fig. 2.
B	2 ea. unit	1 in. x 3 in., hardwood, spaced to protect Items "G". When load is in two units they must extend about full length of car; when in one unit, they must extend from body bolster to body bolster. Nail to floor with 10-D nails, spaced about 2 ft. apart.
C	2 ea. unit	4 in. x 4 in., hardwood, coils 55 in. to less than 72 in. in diameter; 4 in. x 6 in., hardwood, coils 72 in. and over in diameter, to extend 22 inches beyond each end of unit. Bevel ends. Space so that unit will bear but slightly on Items "B" after settling.
D	2	2 in. x 4 in., hardwood. On two unit load, to extend about full length of car. On one unit load, to extend from body bolster to body bolster. Place lightly against Items "C" and nail to floor with 20-D nails spaced about 18 inches apart.
E	6 ea. unit	2 in. x 4 in., hardwood, length equal to distance from Items "D" to side of car. Space as shown and nail to floor with four 20-D nails each.
F	2 ea. unit	2 in. x 8 in., hardwood, length equal to diameter of unit. Chamfer off outside face at each end to provide radius for Items "G".
G	2 ea. unit	2 in. x .050 in. bands. Place around vertical outside diameter of unit; secure to Items "F" to prevent displacement.
H	4 ea. unit	2 in. x 8 in., hardwood, length to suit. Chamfer outside face at each end to provide a radius for Items "J".
J	2 ea. unit	2 in. x .050 in. bands. Place through core and over outside face of unit; secure to Items "H" to prevent displacement.
K	4 ea. unit	2 in. x 4 in., hardwood, length equal to distance from Items "F" to outside ends of Items "L". Nail each to Items "L" with three 20-D nails.
L	2 ea. unit	2 in. x 10 in., hardwood, to extend to outside faces of Items "C". Place tightly against Items "F" and nail to Items "C" with ten 40-D nails each end.
M	4 ea. unit	2 in. x 4 in. x 10 in., hardwood. Place one end of each tightly against Items "L" and nail to Items "C" with eight 40-D nails.

Items "F", "G", "H", "J" and "K" not required for single coils 55 inches and over in diameter and 42 inches or over in width.

Each coil must be secured with four 1 1/4 in. x .035 in. bands, passed through core and around outside face of coil. These bands must be protected by use of suitable protection clips. Each coil must also be secured with one circumferential 1 1/4 in. x .035 in. band, located at center of outside surface of coil.

It is preferable that load consist of two units, one at each end of car, as shown. When load consists of one unit it should be placed in center of car equal distance from each end.

See General Rules 4, 5, 9, 14 and 15 for further details.

COILS OF FLAT STEEL, LESS THAN 60 IN., IN DIAMETER—GONDOLA CARS

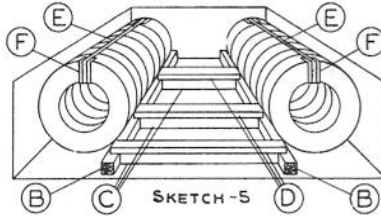
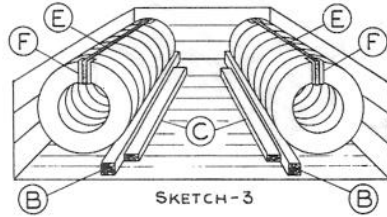
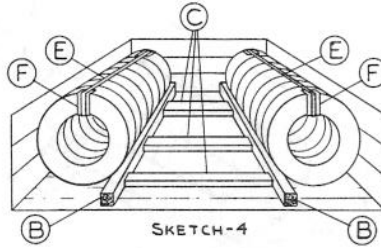
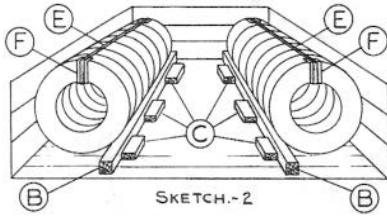
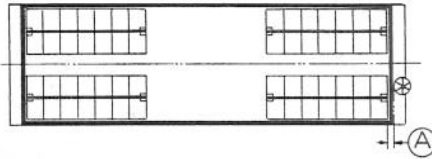
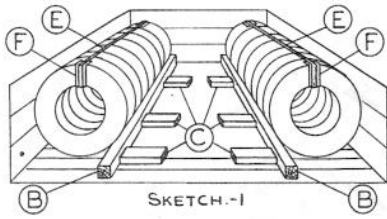

METHOD OF LOADING COILS
SPACED TO PERMIT HANDLING WITH 'ICE TONG' HOOKS

SKETCH-6

SPACER BLOCK (BOTTOM VIEW)

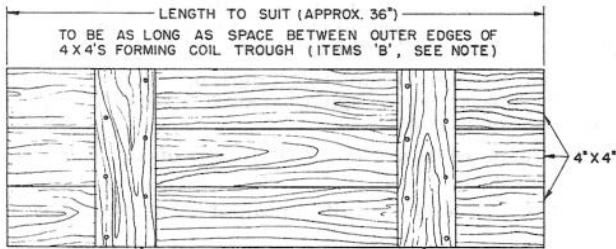

2" X 4" MIN. NAILED TO THE THREE 4" X 4" S AND SPACED TO FIT INSIDE COIL TROUGH FORMED BY ITEMS 'B' (SEE NOTE)

SKETCH-7

SPACER BLOCK

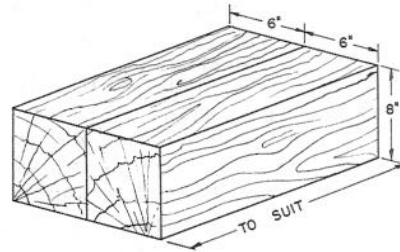

SIDE VIEW

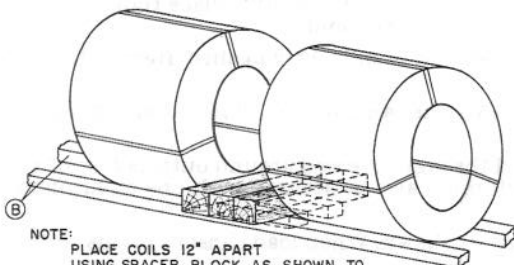

NOTE: PLACE COILS 12" APART USING SPACER BLOCK AS SHOWN, TO MAINTAIN SPACE BETWEEN COILS—USE TWO ITEMS 'B' EACH ROW OF COILS INSTEAD OF ONE ITEM 'B' EACH ROW. ADD ONE UNIT TIE ITEM 'E' AT BOTTOM EACH ROW.

SIDE VIEW

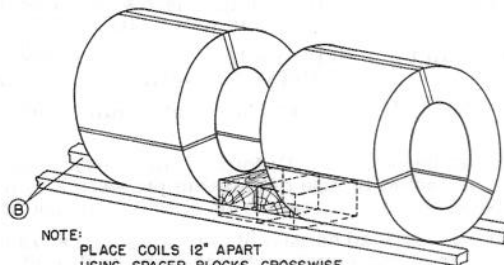

NOTE: PLACE COILS 12" APART USING SPACER BLOCKS CROSSWISE BETWEEN ITEMS 'B' AS SHOWN TO MAINTAIN SPACE BETWEEN COILS—USE TWO ITEMS 'B' EACH ROW OF COILS INSTEAD OF ONE ITEM 'B' EACH ROW. ADD ONE UNIT TIE ITEM 'E' AT BOTTOM EACH ROW.

Sec. 2—Fig. 31

COILS OF FLAT STEEL, LESS THAN 60 IN., IN DIAMETER—GONDOLA CARS

Item	No. of Pcs.	Description
A		Brake wheel clearance. See Fig. 2.
B	1 ea. row	Hardwood, 4 in. x 4 in., 2 ft. longer than row of coils. Locate one at the side of each row toward the center of car.
C	Sketches One and Two, 1 to every 4 ft.	Hardwood, 2 in. x 4 in. x 12 in. Nail each to floor with four 20-D nails.
	Sketch Three, 1 ea. row	Hardwood, 2 in. x 4 in., length about equal to length of row of coils. Locate against Item "B" and nail to floor with 20-D nails, spaced about 18 in. apart.
	Sketch Four, 1 to every 4 ft.	Hardwood, 2 in. x 4 in., length equal to distance between both Items "B". Nail each to floor with four 20-D nails.
	Sketch Five, 1 to every 4 ft.	Hardwood, 2 in. x 4 in., length equal to inside distance between both Items "B". Locate on edge between Items "B". For steel-floored cars only.
D	Sketch Five, 1 to every 4 ft.	Hardwood, 2 in. x 4 in., length slightly less than overall distance of both Items "B". Locate on top of and nail each to Items "B" and "C" with six 20-D nails. For steel-floored cars only.
E	1 ea. row	2 in. x .050 in. or two 1¼ in. x .035 in. high tension bands, passed through core and over outside face of row. For coils secured in groups approximating 54 in. in length, substitute, if desired, three 1¼ in. x .035 in. high tension bands passed through core and over outside face of row, provided Items "B" are continuous. Not required when rows completely fill length of car.
F	To suit	Protection angles, 20 ga., 4 in. wide, applied so as to prevent displacement.

Where coils of mixed diameter are loaded in same unit and smaller coils do not contact Items B, suitable filler pieces should be used between smaller coils and Items B.

See General Rules 4, 5, 9, 14 and 15 for further details.

Sec. 2—Fig. 32

COILS OF FLAT STEEL, LESS THAN 60 IN. IN DIAMETER—GONDOLA CARS

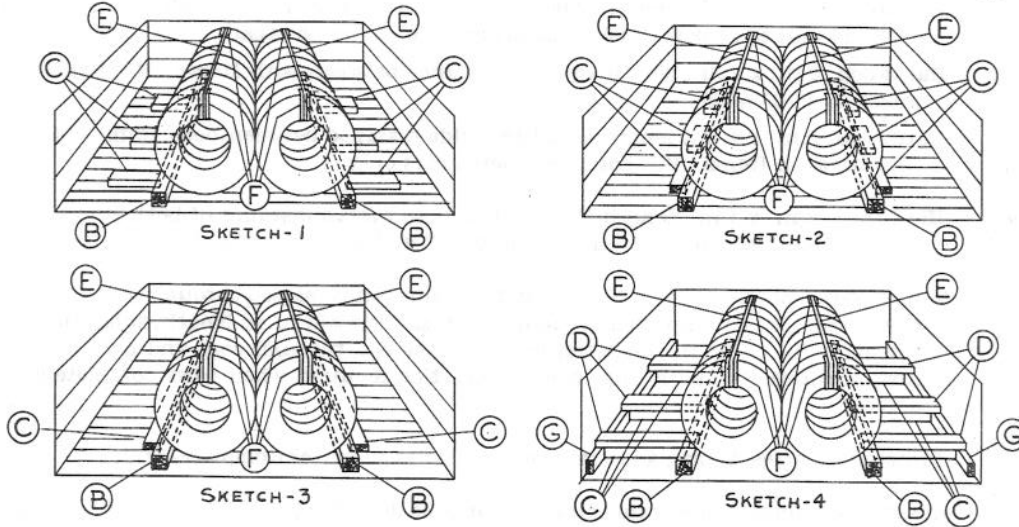
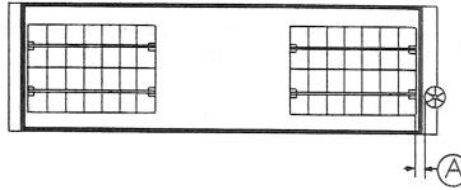

METHOD OF LOADING COILS

SPACED TO PERMIT HANDLING WITH 'ICE TONG' HOOKS

SKETCH-5

SPACER BLOCK (BOTTOM VIEW)

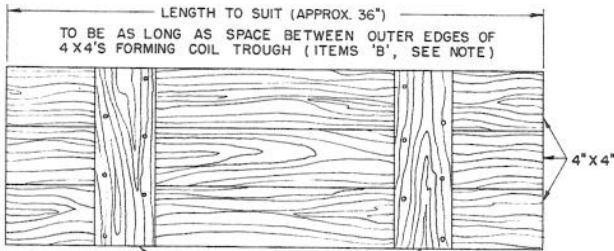

2" X 4" MIN. NAILED TO THE THREE 4 X 4'S AND SPACED TO FIT INSIDE COIL TROUGH FORMED BY ITEMS 'B' (SEE NOTE)

SKETCH-6

SPACER BLOCK

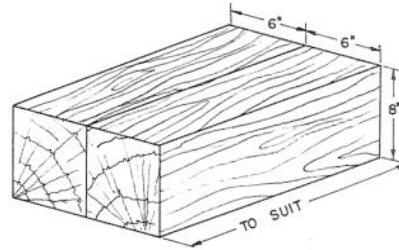

SIDE VIEW

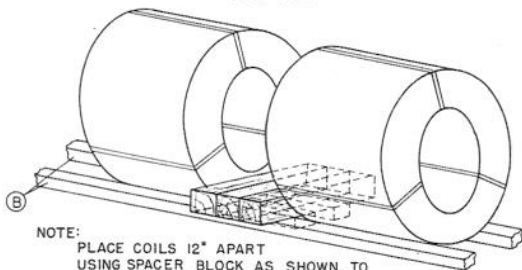

NOTE: PLACE COILS 12" APART USING SPACER BLOCK AS SHOWN, TO MAINTAIN SPACE BETWEEN COILS—USE TWO ITEMS 'B' EACH ROW OF COILS INSTEAD OF ONE ITEM 'B' EACH ROW. ADD ONE UNIT TIE ITEM 'E' AT BOTTOM EACH ROW.

SIDE VIEW

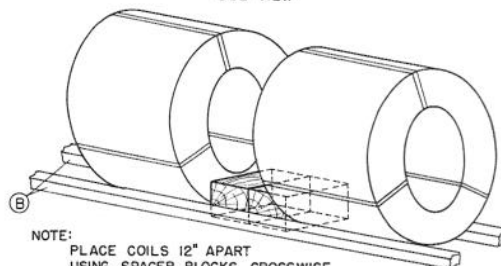

NOTE: PLACE COILS 12" APART USING SPACER BLOCKS CROSSWISE BETWEEN ITEMS 'B' AS SHOWN TO MAINTAIN SPACE BETWEEN COILS—USE TWO ITEMS 'B' EACH ROW OF COILS INSTEAD OF ONE ITEM 'B' EACH ROW. ADD ONE UNIT TIE ITEM 'E' AT BOTTOM EACH ROW.

Sec. 2—Fig. 32

COILS OF FLAT STEEL, LESS THAN 60 IN. IN DIAMETER—GONDOLA CARS

Item	No. of Pcs.	Description
A		Brake wheel clearance. See Fig. 2.
B	1 each row	Hardwood, 4 in. x 4 in., 2 ft. longer than row of coils. Locate one at the side of each row toward the side of car.
C	Sketches One and Two, 1 to every 4 ft.	Hardwood, 2 in. x 4 in. x 12 in. Nail each to floor with four 20-D nails.
	Sketch Three, 1 to each row.	Hardwood, 2 in. x 4 in., length about equal to length of row of coils. Locate against Item "B" and nail to floor with 20-D nails, spaced about 18 in. apart.
	Sketch Four, 1 to every 4 ft.	Hardwood, 2 in. x 4 in., length equal to inside distance between Items "B" and "G". Locate on edge. For steel-floored cars only.
D	1 to every 4 ft.	Hardwood, 2 in. x 4 in., length slightly less than overall distance between Items "B" and "G". Locate on top of and nail each to Items "B", "C" and "G" with six 20-D nails. For steel-floored cars only.
E	1 each row	2 in. x .050 in. or two 1¼ in. x .035 in. high tension bands, passed through core and over outside face of row. For coils secured in groups approximating 54 in. in length, substitute, if desired, three 1¼ in. x .035 in. high tension bands passed through core and over outside face of row, provided Items "B" are continuous. Not required when Items "H" are used.
F	To suit	Protection angles, 20 gage, 4 in. wide, applied so as to prevent displacement.
G	1 each row	Hardwood, 2 in. x 4 in., 2 ft. longer than row of coils. Locate one on edge against each side of car. For steel-floored cars only.
H	1 each double row	2 in. x .050 in. or two 1¼ in. x .035 in. high tension bands, passed through cores of both rows of coils. Not required when Items "E" are used.

Where coils of mixed diameter are loaded in same unit and smaller coils do not contact Items "B", suitable filler pieces should be used between smaller coils and Items "B".

See General Rules 4, 5, 9, 14 and 15 for further details.

COILS OF FLAT STEEL, LESS THAN 60 IN. IN DIAMETER—GONDOLA CARS

WOOD FLOOR CARS
SKETCHES 1, 2 & 3

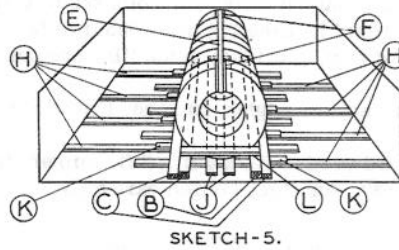
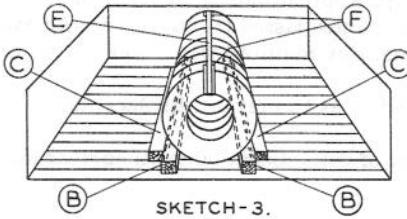
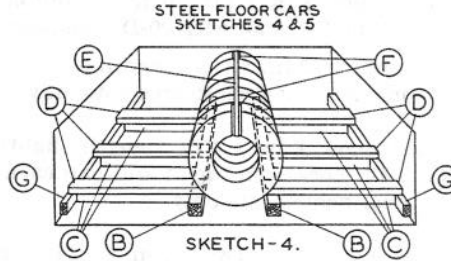
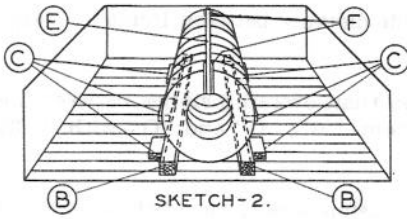
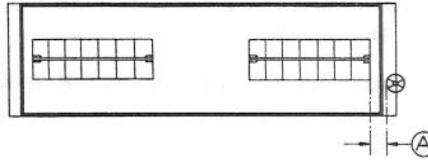
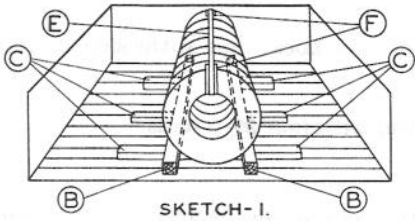

METHOD OF LOADING COILS

SPACED TO PERMIT HANDLING WITH 'ICE TONG' HOOKS

SKETCH-6

SPACER BLOCK (BOTTOM VIEW)

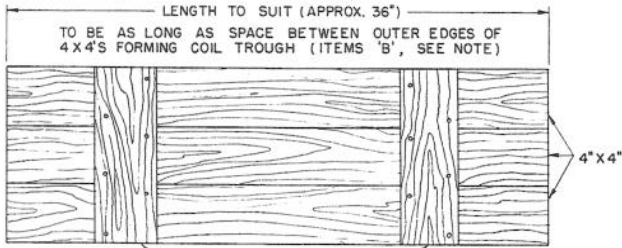

2" X 4" MIN. NAILED TO THE THREE 4" X 4'S AND SPACED TO FIT INSIDE COIL TROUGH FORMED BY ITEMS 'B' (SEE NOTE)

SKETCH-7

SPACER BLOCK

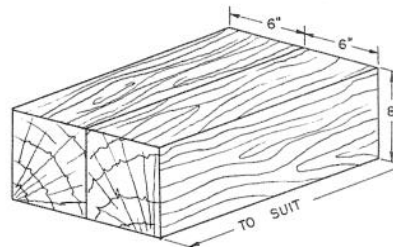

SIDE VIEW

SIDE VIEW

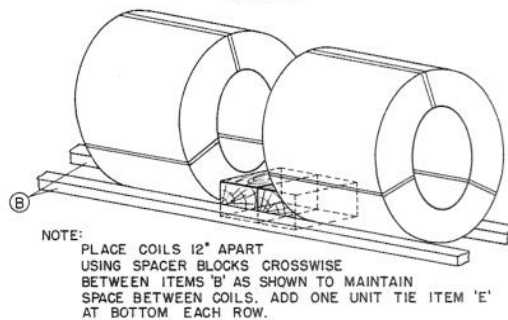
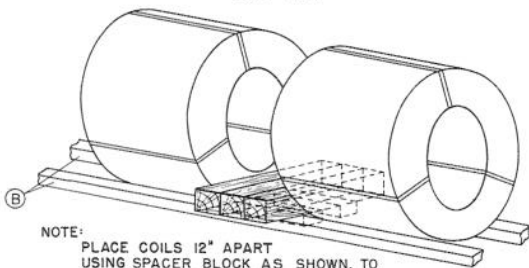

Sec. 2—Fig. 33

COILS OF FLAT STEEL, LESS THAN 60 IN. IN DIAMETER—GONDOLA CARS

Item	No. of Pcs.	Description
A		Brake wheel clearance. See Fig. 2.
B	2	Hardwood, 4 in. x 4 in., 2 ft. longer than row of coils. Locate one at each side of row. On loads per Sketch Five locate so that row of coils will bear but slightly on Items "J".
C	Sketches One and Two, 1 to every 4 ft.	Hardwood, 2 in. x 4 in. x 12 in. Nail each to floor with four 20-D nails.
	Sketch Three, 2.	Hardwood, 2 in. x 4 in., length about equal to length of row of coils. Locate against Item "B" and nail each to floor with 20-D nails, spaced about 18 in. apart.
	Sketch Four, 1 to every 4 ft.	Hardwood, 2 in. x 4 in., length equal to inside distance between Items "B" and "G". Locate on edge.
	Sketch Five, 2.	Hardwood, 2 in. x 4 in., full length of car. Locate against Items "B" and secure to each Item "H" with two 20-D nails at each location.
D	1 to every 4 ft.	Hardwood, 2 in. x 4 in., length to suit. Locate on top of and nail to Items "B", "C" and "G" with six 20-D nails. Not required for loads per Sketches 1, 2, 3 or 5.
E	1	2 in. x .050 in. or two 1¼ in. x .035 in. high tension bands, passed through core and over outside face of row.
F	To suit.	Protection angles, 20 gage, 4 in. wide, applied so as to prevent displacement.
G	2	Hardwood, 2 in. x 4 in., 2 ft. longer than row of coils. Locate one on edge against each side of car. Not required for loads per Sketches 1, 2, 3 or 5.
H	1 to every 2 ft.	Hardwood, 2 in. x 4 in. x 8 ft. Locate from alternate car sides, as shown. Not required for loads per Sketches 1, 2, 3 or 4.
J	2	Hardwood, 1 in. x 4 in., full length of car. Locate suitably spaced between Items "B" and secure to each Item "H" with one 10-D nail. Not required for loads per Sketches 1, 2, 3 or 4.
K	As required.	Hardwood, 2 in. x 4 in. x 12 in. Locate against Items "C" on top of each Item "H" extending from unit to side of car. Secure each with three 20-D nails. Not required for loads per Sketches 1, 2, 3 or 4.
L	2 per unit.	Hardwood, 2 in. x 6 in., length to suit. Locate against ends of unit, as shown, and secure to each Item "B" with three 20-D nails. Not required for loads per Sketches 1, 2, 3 or 4.

Where coils of mixed diameter are loaded in same unit and smaller coils do not contact Items "B", suitable filler pieces should be used between smaller coils and Items "B".

In Sketches 1, 2 and 3, Items "B" are to be placed so that the unit will bear partly against Items "B" and partly at bottom of coils.

On loads per Sketch 5, ends of coils must be located at least 5 feet from ends of car.

See General Rules 4, 5, 9, 14 and 15 for further details.

Sec 2.—Fig. 34

WIRE COILS 44 IN. DIAMETER, OR LESS—GONDOLA CARS

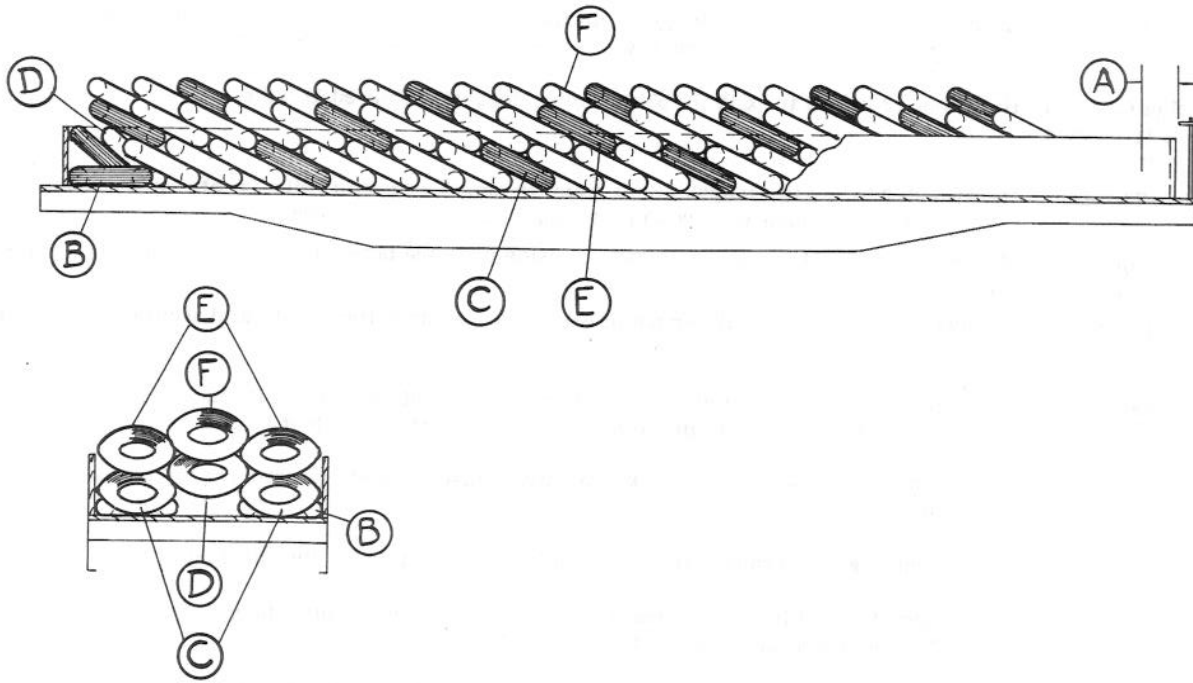

Item	No. of Pcs.	Description
A		Brake wheel clearance. See Fig. 2.
B	2	Place one roll flat on floor, in each corner of car, preferably at end opposite hand brake. On cars having other than horizontal brake wheels starting load at either end of car is permissible.
C	As required.	Place coils at each side of car, at an angle that will keep tops of coils 10 in. to 12 in. below top of car sides.
D	As required.	Place coils between coils "C", at an angle and keep tops of coils about even with top of car sides.
E	As required.	Place coils on top of coils "C", at each side of car, at an angle so that from $\frac{1}{4}$ to $\frac{1}{3}$ diameter of coils are below top of car sides.
F	As required.	Place coils between coils "E" and on top of coils "D", which must have from $\frac{1}{4}$ to $\frac{1}{3}$ diameter of coils below tops of coils "E".

This rule is based on cars having sides 30 in. high. Cars with sides of greater height; the dimensions given for Items "C", "E" and "F" may be increased proportionately.

See General Rules 4 and 5 for further details.

Sec. 2—Fig. 35

STRUCTURAL METAL SHAPES, ETC., SINGLE OVERHANG, LOAD ON ONE BEARING PIECE ON TOP OF STEEL SIDES—GONDOLA CARS

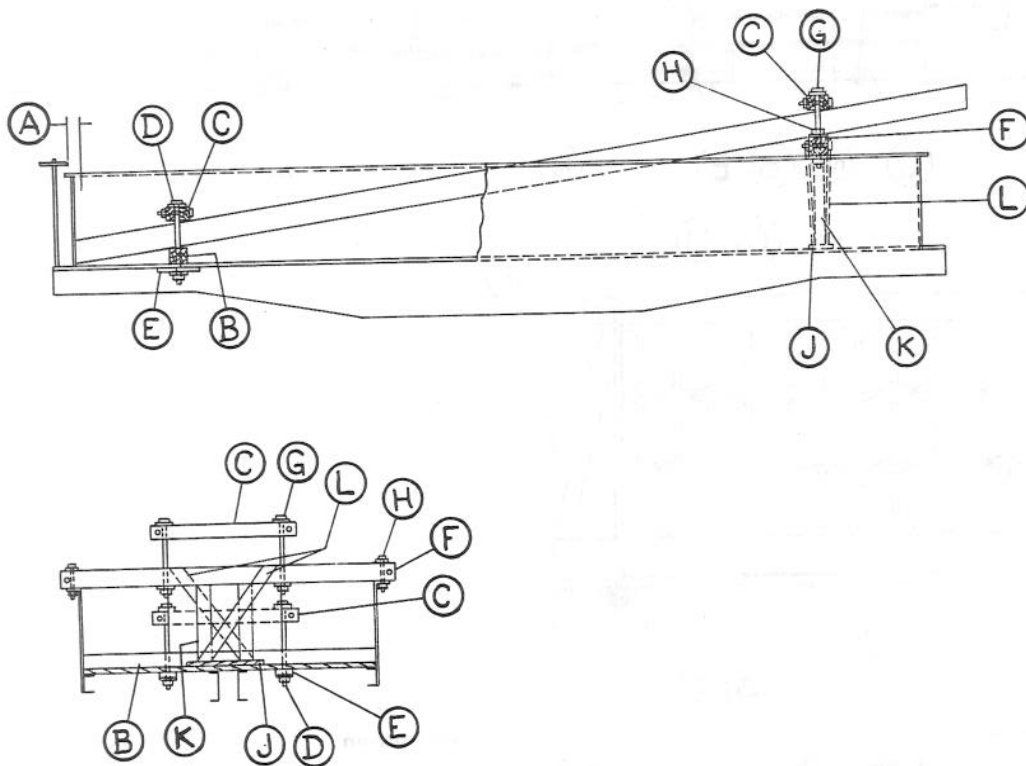

Item	No. of Pcs.	Description
A		Brake wheel clearance. See Fig. 2.
B	1	8 in. hardwood, length about equal to inside width of car, high enough to prevent lading touching floor.
C	2	4 in. x 6 in., hardwood, length to suit. Use $\frac{1}{2}$ in. dia. bolt, crosswise, with washers, at each end to prevent splitting.
D	2	$\frac{3}{8}$ in. dia. rods, length to suit, with washers. Pass through Items "B", "C", floor and "E".
E	2	4 in. x 4 in. x 18 in., hardwood, or $\frac{1}{2}$ in. x 4 in. x 18 in. plate.
F	1	6 in. x 8 in., hardwood, length to suit. Use $\frac{1}{2}$ in. dia. bolt, crosswise, with washers at each end to prevent splitting. Locate to suit, between bolster and end of car.
G	2	1 in. dia. rods, length to suit, with washers. Pass through Items "C" and "F".
H	2	$\frac{3}{8}$ in. dia. bolts, length to suit, with washers, through Item "F" and top side angle.
J	1	2 in. x 10 in., hardwood, length to suit. Nail to floor with six 20-D nails.
K	2	6 in. x 8 in., hardwood posts, spaced about 24 in. apart, located on top of Items "J". Toe-nail to Items "F" and "J" with four 10-D nails at each location. Not required when weight of load, on Item "F", does not exceed 5,000 lbs.
L	2	2 in. x 6 in., hardwood, length to suit. Locate diagonally and nail each to Items "F" and "K" with three 20-D nails at each location.

Total weight of material loaded in this manner must not exceed thirty percent of load weight limit.

Material secured in accordance with other rules and figures may be loaded on floor of car.

See General Rules 4, 5, 7, 9, 14, 15 and 16 for further details.

Sec. 2—Fig. 36

STRUCTURAL METAL SHAPES—SINGLE CAR, OVERHANGING BOTH ENDS—FLAT OR GONDOLA CARS

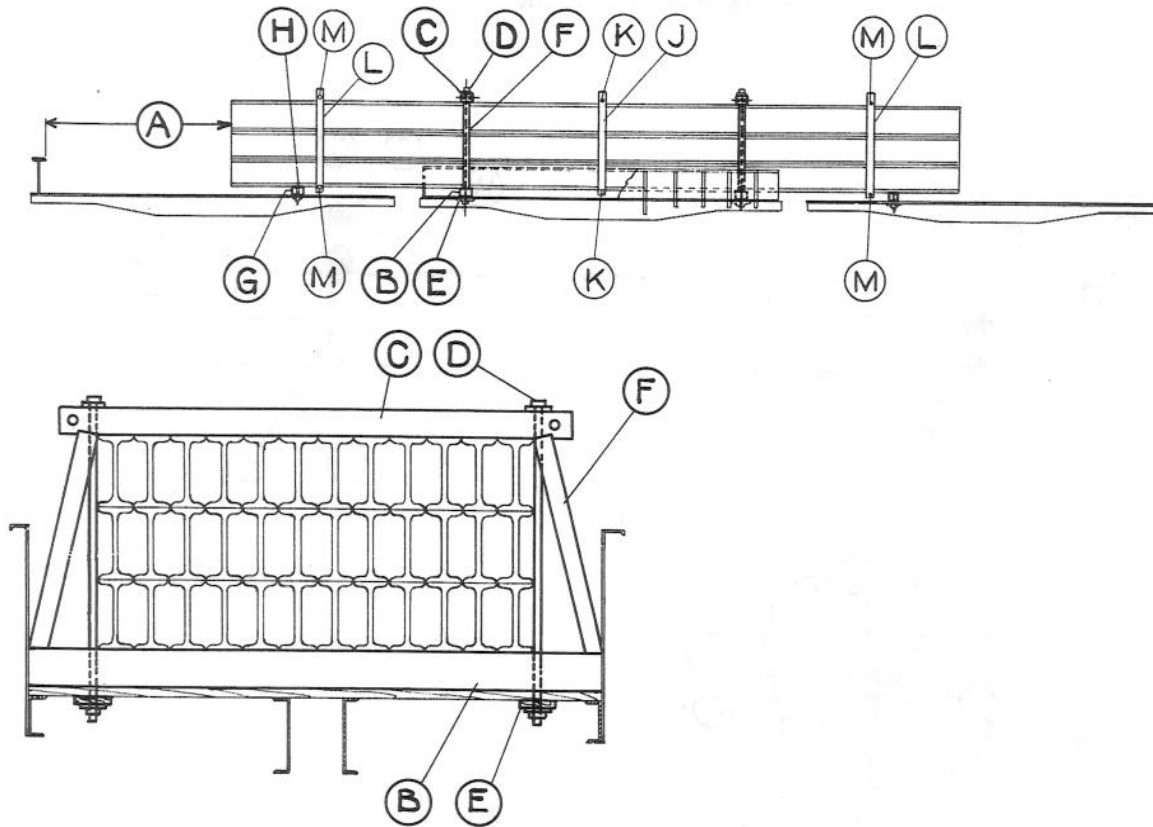

Item	No. of Pcs.	Description
A		Brake wheel clearance. See Fig. 2.
B	2	8 in. wide, hardwood, length equal to width of car, high enough to provide 4 in. clearance between load and floor or end gates of idler cars. When loaded flatwise, to prevent flanges, less than 1 in. thick, on structural material weighing over 20,000 lbs. per bearing piece, from cutting into bearing pieces, blocks, thicker than the depth of flanges, must be placed underneath the bottom pieces of material. When only one is used at each end of material, its length must be equal to the width of Item "B", and wide enough to fill about 75% of space between flanges. Each block must be secured to prevent displacement, except when 4 ft. long. When two blocks are used, the width of each must not be less than its height, 4 ft. long and located close to flanges. When material is 12 in. wide, or more, place the block, or blocks, under each outside piece only, and when less than 12 in. wide, they must be placed under the two outside pieces of material, each side of load.
C	2	4 in. x 6 in., hardwood, $\frac{1}{2}$ in. dia. bolt, with washers at each end to prevent splitting.
D	4	$\frac{1}{4}$ in. dia. rod, with washers.
E	4	4 in. x 4 in. x 18 in., hardwood, or $\frac{1}{2}$ in. x 4 in. x 18 in. plate.
F	4	4 in. x 6 in., hardwood, on loads over 2 ft. to 5 ft., toenailed to Items "B" and "C" with three 40-D nails at each location. Not required when load is 2 ft. high or less, or when width of material exceeds 2 ft. except when height of load is greater than the width of the individual pile in the load. When Item "F" cannot be effectively applied on load, the height of which is less than car side, blocking sufficient to fill space between load and car sides must be applied and secured to prevent displacement.
G	2	8 in. wide, hardwood, length equal to width of car. Not required when material is rigid enough to maintain clearance, as per Item "B".
H	2	$\frac{1}{4}$ in. x 6 in., length equal to Item "G". Secure with $\frac{3}{4}$ in. countersunk head bolts through Items "G" and car floor.
J	2	6 in. x 8 in., hardwood, length to suit. Use $\frac{1}{2}$ in. dia. bolt, crosswise, with washers, at each end to prevent splitting. Locate at center of load.
K	2	1 in. dia. rod, with nuts and washers, long enough to extend through top and bottom of Items "J".
L	4	6 in. x 8 in., hardwood, length to suit. Use $\frac{1}{2}$ in. dia. bolt, crosswise, with washers, at each end to prevent splitting. Locate at ends of load inside of Items "G" and "H". Required only when overhang exceeds 10 ft.
M	4	1 in. dia. rod with washers, long enough to extend through top and bottom of Items "L". Required only when Items "L" are used.

Loads exceeding weights and dimensions, as per Rule 16, must not be loaded in this manner.

Items "J" and "K", and Items "L" and "M" required only for long flexible material.

Items "J" and "K" not required for gondola cars.

Items "J" and "K", and Items "L" and "M" not required when substituted with two 2 in. x .050 in. high tension bands, located as close together as possible.

See General Rules 4, 5, 6, 7, 8, 9, 12, 13, 14, 15 and 16 for further details.

Sec. 2—Fig. 37

STRUCTURAL METAL SHAPES—SINGLE CAR—HEIGHT MUST NOT EXCEED 5 FT. ABOVE FLOOR—FLAT OR GONDOLA CARS

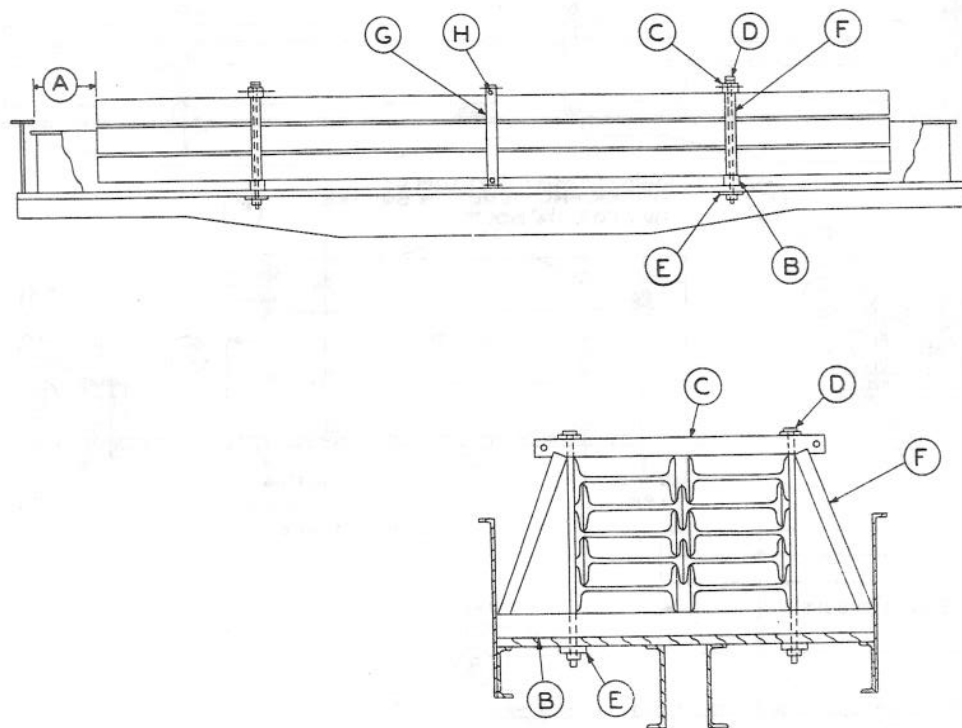

Item	No. of Pcs.	Description
A		Brake wheel clearance. See Fig. 2.
B	2	6 in. x 8 in., hardwood, length about equal to width of car.
C	2	6 in. x 8 in., hardwood, ½ in. dia. bolt, with washers, at each end to prevent splitting.
D	4	1¼ in. dia. rod, with washers.
E	4	4 in. x 4 in. x 18 in., hardwood, or ½ in. x 4 in. x 18 in. plate.
F	4	4 in. x 6 in., hardwood, toe-nailed to Items "B" and "C" with three 40-D nails at each location. Not required on piles 2 ft. or less in height. When vacant space between sides of piles and sides of car does not permit application at an angle of 15 degrees or more, suitable blocking or bracing must be applied so as to prevent top portion of pile from leaning. Flat cars must not be used when it is impossible to apply at an angle of 15 degrees or more.
G	2	6 in. x 8 in., hardwood, length to suit, ½ in. dia. bolt, with washers, at each end to prevent splitting.
H	2	1 in. dia. rod, with washers.

Items "G" and "H" not required when substituted with two 2 in. x .050 in. high tension bands, located as close together as possible.

Material need not be secured when loaded below top of gondola car sides, with end gates raised and fastened, when the total vacant space across car between piles, and between the load and car sides, does not exceed 18 inches.

See General Rules 4, 5, 6, 9, 12, 14 and 15 for further details.

Sec. 2—Fig. 38

LONG MATERIAL, WITH OR WITHOUT SLIDERS, 7 FT. HIGH OR LESS ABOVE BEARING PIECES—TWO FLAT OR GONDOLA CARS

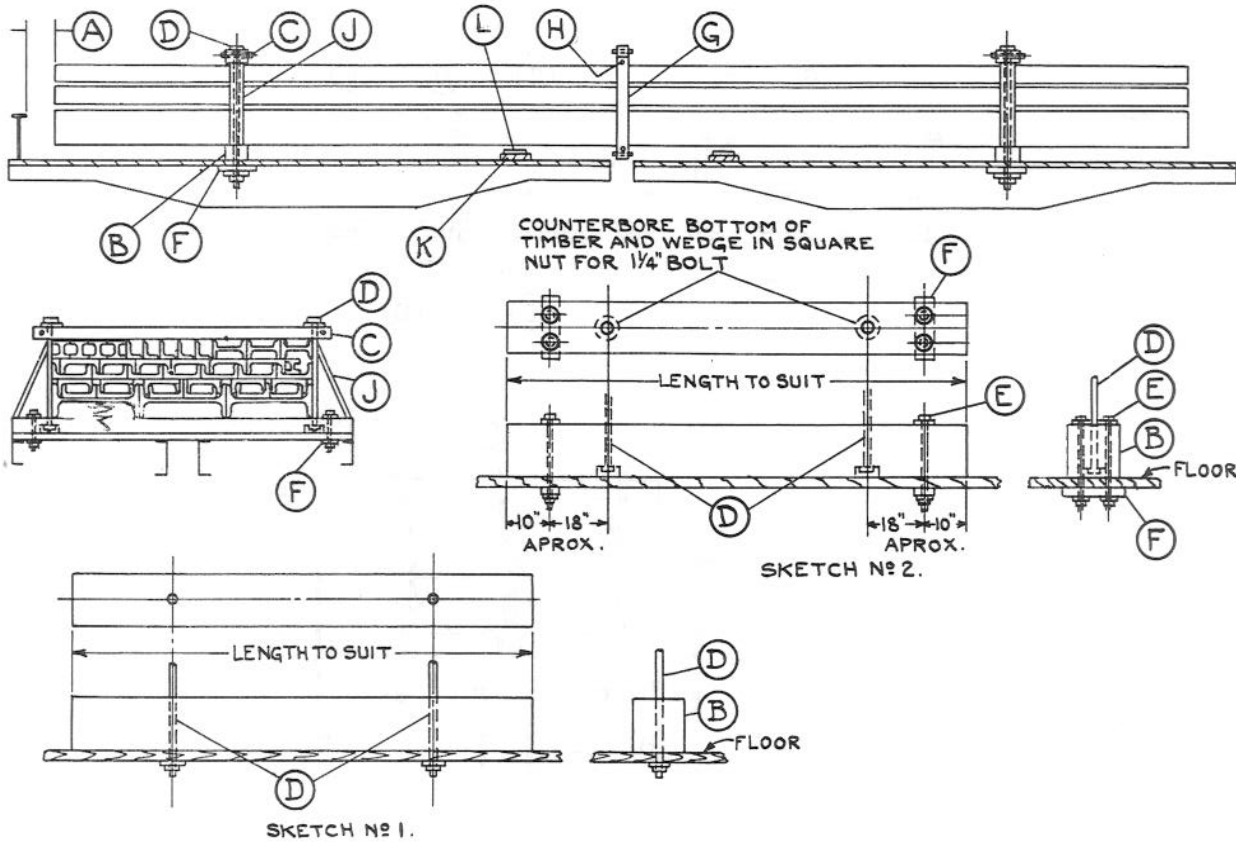

Item	No. of Pcs.	Description
A		Brake wheel clearance. See Fig. 2.
B	2	8 in. x 8 in., hardwood, for loads 80,000 lbs. or less, and 10 in. x 10 in., hardwood, for loads over 80,000 lbs. per bearing piece, prepared and secured per sketch 1 or 2. To prevent flanges, less than 1 in. thick, on structural material weighing over 20,000 lbs. per bearing piece, from cutting into bearing pieces, blocks, thicker than the depth of flanges, must be placed underneath the bottom pieces of material. When only one is used at each end of material, its width must be equal to the width of Item "B", and long enough to fill about 75 percent of space between flanges. It must be secured to prevent displacement, except when 4 ft. long and placed lengthwise of car. When two are used, the width of each must not be less than its height. Each must be 4 ft. long and located close to flange and lengthwise of car. When material is 12 in. wide, or more, place the block, or blocks, under each outside piece only, and when material is less than 12 in. wide, they must be placed under the two outside pieces each side of load. Not required when pivoted bolsters are used.
C	2	4 in. x 6 in., hardwood, $\frac{1}{2}$ in. bolt, with washers, at each end to prevent splitting.
D	4	$1\frac{1}{4}$ in. dia. rod with washers.
E	8	$\frac{3}{8}$ in. dia. bolt with washers. Not required for bearing pieces, per sketch 1.
F	4	4 in. x 4 in. x 18 in., hardwood, or $\frac{1}{2}$ in. x 4 in. x 18 in. plate.
G	2 ea. binder	6 in. x 8 in., hardwood $\frac{1}{2}$ in. dia. bolt, with washers, at each end to prevent splitting.
H	2 ea. binder	$1\frac{1}{4}$ in. dia. rod, with washers. Use two binders, Items "G" and "H", for loads 5 ft. high or over, located between and 3 ft. from each Item "B".
J	4	4 in. x 6 in., hardwood, on loads 2 ft. to 5 ft. high, and for structural beams 24 in. or more wide up to 6 ft., toe-nailed to Items "B" and "C" with three 40-D nails at each location. Not required for structural material 24 in. wide or more, unless the height exceeds the width of the individual pile in the load.
K	2	6 in. x 8 in., hardwood, for loads 5 ft. to 7 ft. high, except for structural beams as mentioned above loaded up to 6 ft. high, toe-nailed to Items "B" and "C" with three 40-D nails at each location. The incline of braces must be as great as possible.
L	2	8 in. wide, height must be 4 in. lower than Items "B", except when load might be damaged by permanent deflection, they may be 2 in. lower. Required only for flexible material.
		$\frac{1}{4}$ in. x 6 in., secured with counter sunk head bolts, $\frac{3}{4}$ in. dia., through Items "K" and floor. Required only for flexible material.

Place longest portion of load at bottom, as near to center of load as possible. Place piles close together, or fill spaces between piles with blocking at Item "B" and at Items "G" and "H", to make compact load.

Items "G" and "H" not required when substituted with two 2 in. x .050 in. high tension bands, located as close together as possible.

See General Rules 4, 5, 6, 7, 9, 12, 13, 14, 15 and 18 for further details.

Sec. 2—Fig. 39

CONCRETE REINFORCING RODS, ETC., 3 FT. HIGH OR LESS ABOVE BEARING PIECES, ON TWO FLAT OR GONDOLA CARS

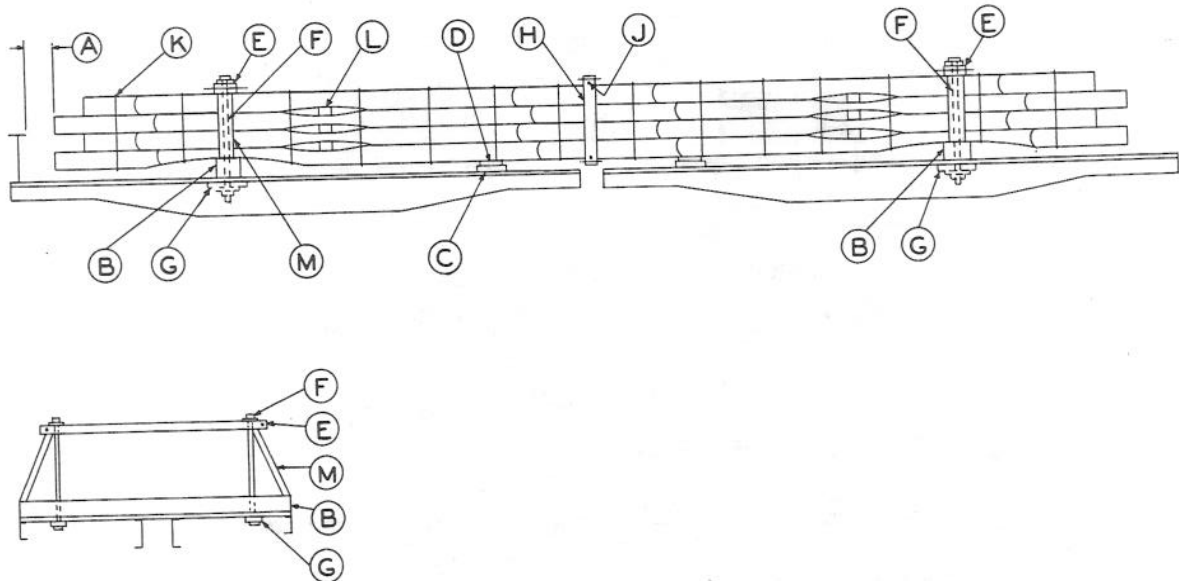

Item	No. of Pcs.	Description
A		Brake wheel clearance. See Fig. 2.
B	2	8 in. x 8 in., hardwood, for loads 80,000 lbs. or less, 10 in. x 10 in., for load over 80,000 lbs., per bearing-piece, Items "B".
C	2	8 in. wide, hardwood, height must be 4 in. lower than Item "B", except when load might be damaged by permanent deflection, they may be 2 in. lower.
D	2	$\frac{1}{4}$ in. x 6 in., secured with two countersunk head bolts, $\frac{3}{4}$ in. dia., through Item "C" and floor.
E	2	4 in. x 6 in., hardwood. Use one bolt, $\frac{1}{2}$ in. dia., crosswise, at each end to prevent splitting.
F	4	$1\frac{1}{4}$ in. dia. rod, with washers.
G	4	4 in. x 4 in. x 18 in., hardwood, or $\frac{1}{2}$ in. x 4 in. x 18 in. plate.
H	2	6 in. x 8 in., hardwood. Use one bolt, $\frac{1}{2}$ in. dia., crosswise, at each end to prevent splitting.
J	2	$1\frac{1}{4}$ in. dia. rod, with washers.
K	As required.	10 strands No. 11 ga. wire, twisted in cable form, or equivalent, tightly secured around load, 5 ft. from each end, spaced not more than 5 ft. apart.
L	To Suit	Use spacing blocks to facilitate unloading, if desired.
M	4	4 in. x 6 in., hardwood, on loads over 2 ft. high above Items "B", toe-nailed to Items "B" and "E", with three 40-D nails at each location. Not required for loads 2 ft. and not over 3 ft. high when Items "K" are used.

Items "H" and "J" not required when substituted with two 2 in. x .050 in. high tension bands, located as close together as possible.

See General Rules 4, 5, 6, 7, 9, 12, 14, 15 and 18 for further details.

Sec. 2—Fig. 40

STRUCTURAL STEEL SHAPES AND FLEXIBLE REINFORCING RODS, SECURED WITH HIGH TENSION BANDS ON ONE CAR WITH OR WITHOUT OVERHANGS; TWO CARS OVERHANGING THIRD CAR, OR THREE CARS— FLAT OR GONDOLA CARS

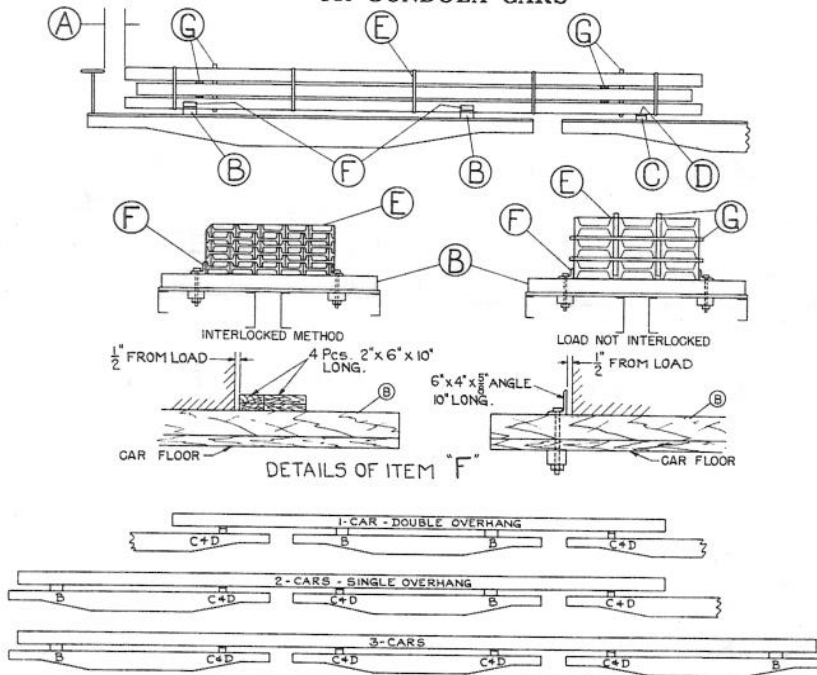

Item	No. of Pcs.	Description
A		Brake wheel clearance. See Fig. 2.
B	2	10 in. wide, hardwood, length 2 in. less than width of car, high enough to provide 4 in. clearance between load and floor or end gates of idler cars. Bolt to flat car floor with two 3/4 in. dia. bolts, long enough to pass through floor and 4 in. x 4 in. x 18 in. hardwood, or 1/2 in. x 4 in. x 18 in. plate under floor.
C	For each overhang resting on idler car—1. For twin load—1 each carrying car and 1 each overhang. For triple load 1 each carrying car, 2 on idler car. For flexible material, add one at each end when overhang exceeds 12 ft.	6 in. x 8 in. hardwood, length 2 in. less than width of car, bolted to floor with two 3/4 in. dia. countersunk bolts, long enough to pass through floor and 4 in. x 4 in. x 18 in. hardwood, or 1/2 in. x 4 in. x 18 in. plate under floor.
D	1 each Item "C"	1/4 in. x 6 in. plate, length same as and secured to Item "C".
E	To suit	2 in. x .050 in. high tension bands. Locate about 3 ft. from Items "B" and "C" about 5 ft. from each end of load and space intermediate bands not over 9 ft. apart in gondola cars and 6 ft. apart on flat cars.
F	8 each Item "B"	Gondola cars. 2 in. x 6 in. x 10 in. hardwood. Place two about 1/2 in. from and paralleling load and two butted against same and paralleling Item "B". Place one on top of the other and nail lower piece to Items "B" with four 30-D nails and top piece to the one below with four 30-D nails.
	2 each Item "B"	Flat cars. 6 in. x 4 in. x 5/8 in. angles 10 in. long. Locate about 1/2 in. from and paralleling each side. Secure each with one 3/4 in. dia. bolt through Item "B", car floor and 4 in. x 4 in. x 18 in. hardwood, or 1/2 in. x 4 in. x 18 in. plate under floor.
G	To suit	3 in. x 4 in. hardwood. Vertical separators, when used, must be secured to prevent displacement and must not extend below bottom of load. Horizontal separators, when used, must extend at least 3 in. beyond each side of load. Not required for sheet steel piling and interlocked structural steel shapes.

Height of load must not exceed 30 in. above floor when loaded on flat cars nor extend above top of car sides when loaded in gondola cars and in no case must the height exceed the width at base.

Material on flat cars must be effectively interlocked.

When necessary to prevent cutting of bands, place metal or wood protectors under bands at points of contact. Band protectors, when used, must be secured to prevent displacement.

See General Rules 4, 5, 6, 8, 9, 12, 13, 14, 15, 16 and 18 for further details.

LONG FLEXIBLE MATERIAL, WITH SLIDERS, 7 FT. HIGH OR LESS ABOVE BEARING-PIECES, ON TWO FLAT CARS OVERHANGING THIRD CAR

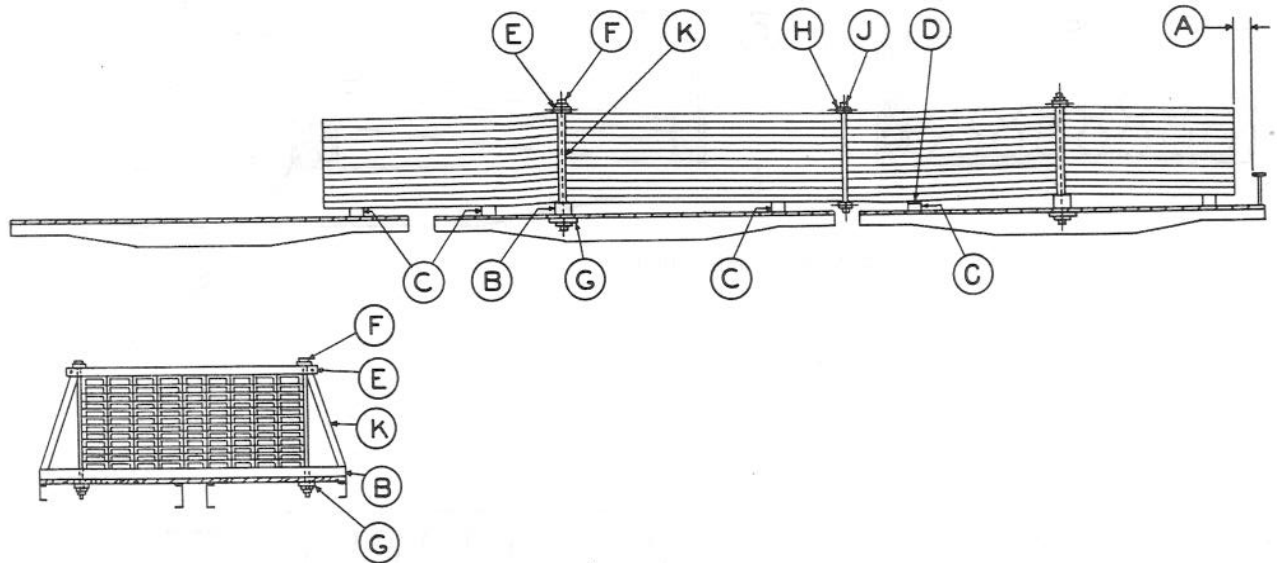

Item	No. of Pcs.	Description
A		Brake wheel clearance. See Fig. 2.
B	2	8 in. x 8 in., hardwood, for loads 80,000 lbs. or less, 10 in. x 10 in., for loads over 80,000 lbs., per bearing piece Items "B".
C	5	8 in. wide, hardwood, height must be 4 in. lower than Item "B", except when load might be damaged by permanent deflection they may be 2 in. lower.
D	5	¼ in. x 6 in., secured with 2 countersunk head bolts, ¾ in. dia.
E	2	4 in. x 6 in., hardwood. ½ in. bolt, with washers, at each end to prevent splitting. Should just clear load when Item "K" is used.
F	4	1¼ in. dia. rod, with washers.
G	4	4 in. x 4 in. x 18 in., hardwood, or ½ in. x 4 in. x 18 in. plate.
H	2	4 in. x 6 in., hardwood, ½ in. bolt, with washers, at each end to prevent splitting.
J	2	1¼ in. dia. rod, with washers.
K	4	4 in. x 6 in., hardwood, on loads 2 ft. to 5 ft. high and structural beams 24 in. or more wide up to 6 ft., toe-nailed to Items "B" and "E" with three 40-D nails at each location. Not required for structural material 24 in. wide or more, unless the height exceeds the width of the individual pile in the load.
		6 in. x 8 in., hardwood, for loads 5 ft. to 7 ft. high, except structural beams as mentioned above loaded up to 6 ft. high, toe-nailed to Items "B" and "E" with three 40-D nails at each location. The incline of braces must be as great as possible.

Place longest piece at bottom as near center of load as possible. Place piles close together. Fill space between piles with blocking at Items "B" and at Items "H" and "J" to make compact load.

Items "H" and "J" not required when substituted with two 2 in. x .050 in. high tension bands, located as close together as possible.

See General Rules 4, 5, 6, 7, 8, 9, 12, 13, 14, 15 and 18 for further details.

Sec. 2—Fig. 42

AXLES, LOOSE WHEELS, TIRES, ETC.—GONDOLA CARS

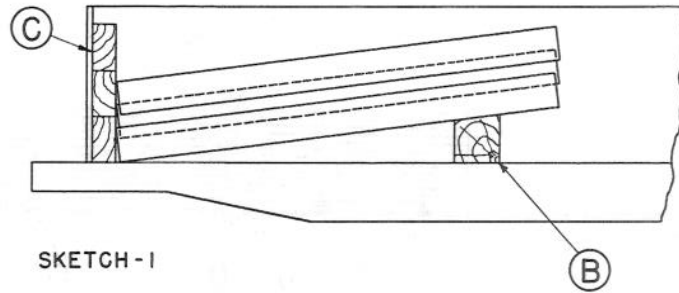
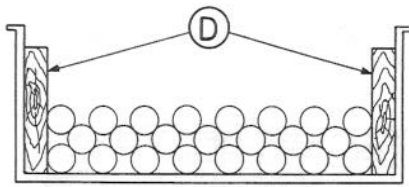

AXLES SKETCH-1

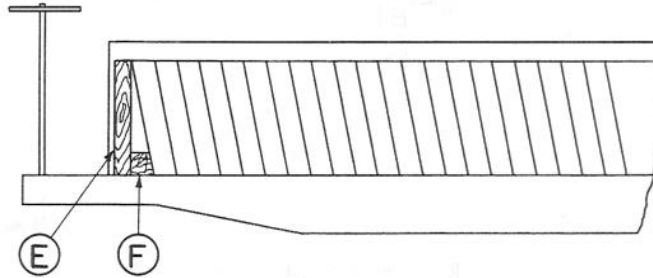
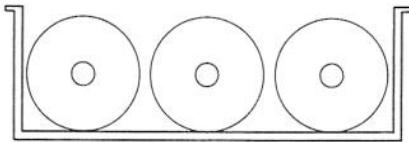

WHEELS SKETCH-2

Item	No. of Pcs.	Description
A		Brake wheel clearance. See Fig. 2.
B	Sketch One, 1.	3 in. x 3 in., length to suit. Locate about 12 in. from end of pile.
C	Sketch One, as required.	2 in. thick, length equal to width of car, height to suit. Use optional.
D	Sketch One, 4.	Suitable fillers, height to suit. Use optional.
E	Sketch Two, 1 per row.	2 in. x 6 in., length equal to height of pile. Use optional.
F	Sketch Two, 1.	4 in. x 4 in., length equal to width of car.

Items "B", "C" and "D" not required when axles are loaded crosswise.

Hopper or self-clearing gondola cars must not be used for such loading.

See General Rules 4, 5, 9 and 14 for further details.

Sec. 2—Fig. 43

BILLETS, INGOTS, SLABS, ETC.—GONDOLA CARS

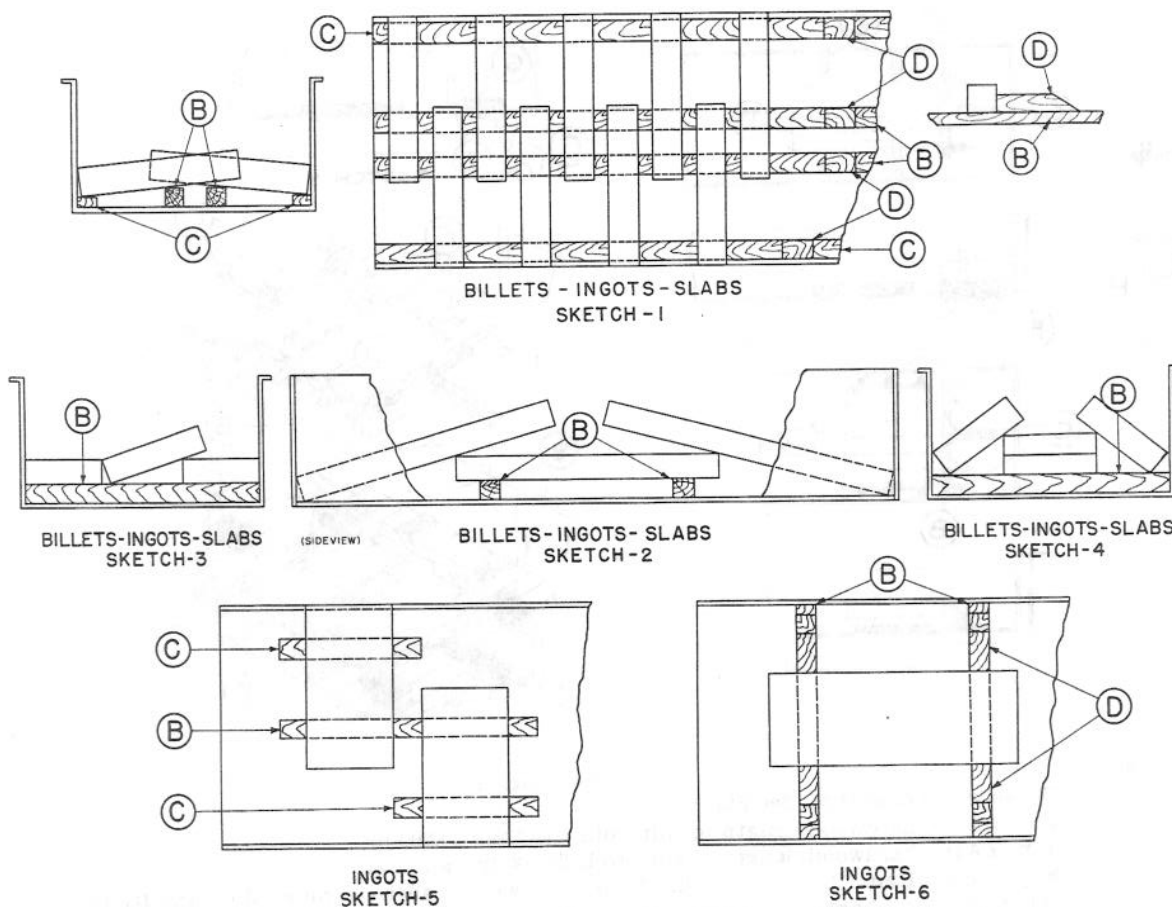

Item	No. of Pcs.	Description
A		Brake wheel clearance. See Fig. 2.
B	Sketch One, 2.	4 in. x 4 in., length to suit. Locate about 12 in. from end of pile. Only one required when located at center of car provided material is long enough to overlap same 12 inches.
	Sketch Two, 2.	4 in. x 4 in., length to suit. Locate about 12 in. from ends of center pile, crosswise of car. Use optional.
	Sketches Three and Four, 2 per pile.	4 in. x 4 in., length equal to width of pile. Use optional.
	Sketch Five, 1.	4 in. x 4 in., length to suit. Locate at center of car.
	Sketch Six, 2 per pile.	4 in. x 4 in., length equal to width of car. Locate about 15 in. from ends of pile. Use optional.
C	Sketches One and Five, 2.	2 in. x 4 in., length to suit.
D	Sketch One, 1 ea.	4 in. x 4 in. x 18 in. Locate against load and secure to Items "B" and "C" with five 40-D nails.
	Items "B" and "C".	Required only when material does not extend from end to end of car.
	Sketch Six, 2 ea.	4 in. x 4 in. x 18 in. Locate against load and secure to Items "B" with five 40-D nails.
	Item "B".	When Items "B" are not used, locate one 2 in. x 4 in., length to suit, against each side of load and secure to floor with six 40-D nails.

When loaded in accordance with Sketch 2, load must be secured so as to prevent moving or tipping toward sides of car when the total vacant space across car between piles and between the load and car sides exceeds 8 inches.

When loaded in accordance with Sketch 4, center section may consist of two or more side by side tiers of one or more slabs each, and side sections must have an angularity of not more than 45 degrees.

When loaded in accordance with Sketches 5 and 6, units must have 30 in. vacant space at ends of car.

Round, Hexagon, Octagon and Corrugated ingots must be loaded in accordance with Figure 47.

Hopper or self-clearing gondola cars must not be used for such loading.

See General Rules 4, 5, 9 and 14 for further details.

Sec. 2—Fig. 44

MILL ROLLS, LENGTHWISE—GONDOLA CARS

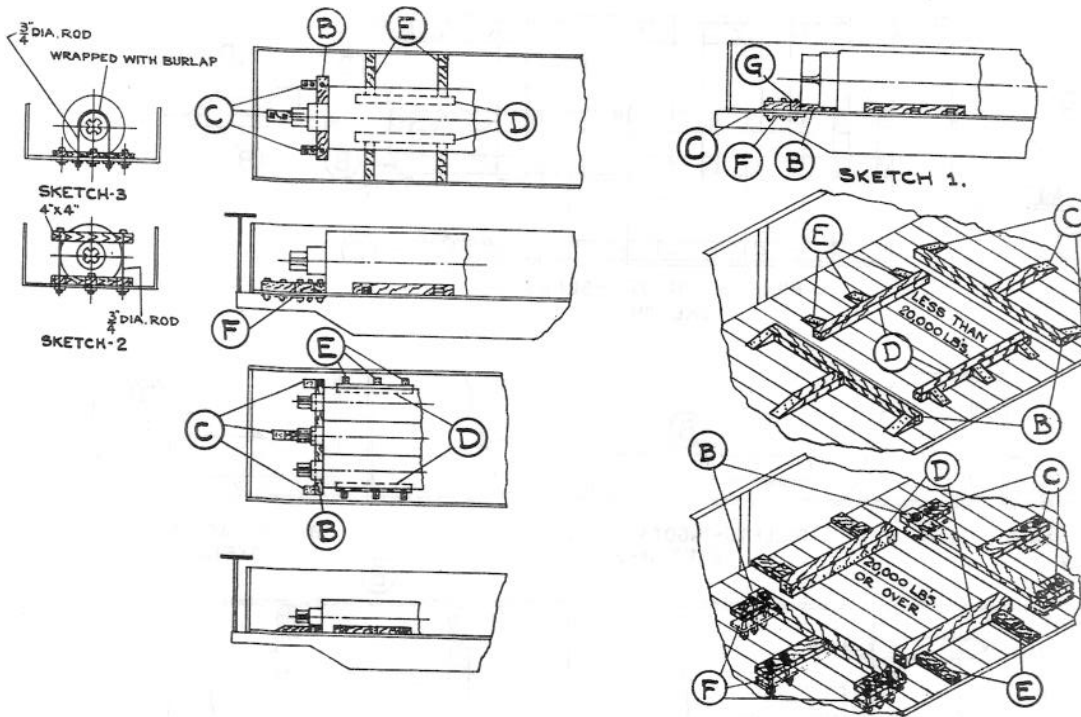

Item	No. of Pcs.	Description
A		Brake wheel clearance. See Fig. 2.
B	2	4 in. x 4 in., hardwood, length to suit, rolls less than 20,000 lbs. 4 in. x 6 in., hardwood, length to suit, rolls 20,000 lbs. and over. Secure each Item "B" with 2 bolts, 3/4 in. dia., with washers, through floor and Items "F". When Items "B" are less than 3 in. thick, they must completely fill space between the shoulders or rolls and Items "G". See sketch 1.
C	6 per roll	Substitute, if desired, for rolls less than 20,000 lbs., two pieces of 2 in. x 4 in., hardwood. Nail lower piece to floor with 30-D nails spaced about 6 in. apart, and top piece to one below in like manner. 4 in. x 4 in. x 12 in., hardwood, wedge shaped, rolls less than 20,000 lbs. Secure each with five 40-D nails. 4 in. x 6 in. x 14 in., hardwood, rolls 20,000 lbs. and over. Secure each with 2 bolts, 3/4 in. dia., with washers, through floor and Items "F". Increase length of center item, when necessary, to admit of applying nails or bolts. When Items "G" are used, Items "C" and "G" must be of equal height. See sketch 1.
D	2 per roll	4 in. x 4 in., hardwood, rolls 28 in. dia. or less. For rolls over 28 in. dia., height of Items "D" must be 1/2 dia. of roll, maximum height 10 in., width equal to height, length equal to 2/3 length of body of roll. Secure to floor with 40-D nails.
E	Each Item "D" 6 ft. long or less, 3. Each Item "D" over 6 ft., add 1 for each additional 4 ft. or less in length.	4 in. x 4 in. x 12 in., hardwood, wedge shaped. Secure each with five 40-D nails.
F	Rolls weighing 20,000 lbs. or over, 2 each, Item "D" 6 per roll	2/3 height of Items "D", minimum thickness 2 in., 4 in. wide, hardwood. When applied in two or more sections, bottom section must be long enough to fill space between Items "D" and car sides, nailed to floor with 30-D nails. Nail top sections to the one below with 30-D nails.
G	2 per roll	4 in. x 4 in. x 18 in., hardwood, or 1/2 in. x 4 in. x 18 in. plate. 6 in. wide, high enough to provide 4 in. bearing against end of roll, hardwood, length to suit. Secure each with 2 bolts, 3/4 in. dia., with washers through floor and Items "F". Required only when Items "B" are less than 3 in. thick. See sketch 1.

When loaded two or more, side by side, and their combined weight is 20,000 lbs. or more, Items "B" and "C" must be added directly opposite same. When so loaded, use one Item "D" against roll, on side nearest center of car. Items "E" must be used.

Rolls with short bodies, 24 in. diameter and over, and exceptionally long bearings, must be secured as per either sketches 2 or 3.

One or more rolls, each weighing 13,000 lbs. or less, may be loaded against car sides provided rolls of equal weight are added directly opposite same. When so loaded, use one Item "D" against roll, on side nearest center of car. Items "E" must be used.

See General Rules 4, 5, 9, 14, and 15 for further details.

MILL ROLLS WITH SHORT BODIES 24 INCHES DIAMETER AND OVER—GONDOLA CARS

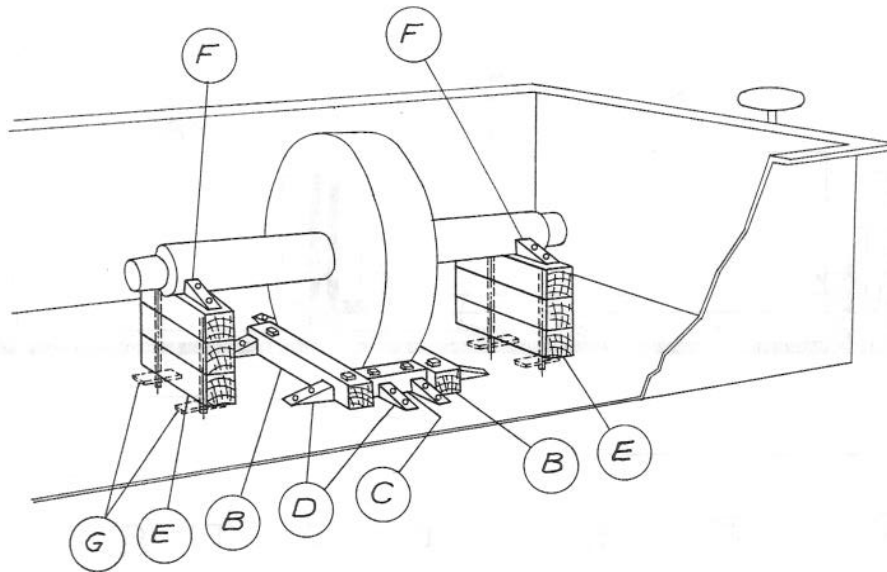

Item	No. of Pcs.	Description
A		Brake wheel clearance. See Fig. 2.
B	2 ea. roll.	4 in. x 6 in., hardwood, length to suit. For rolls 20,000 lbs. and over, secure each with two bolts $\frac{3}{4}$ in. in dia., with washers, through floor and Items "G". For rolls under 20,000 lbs., substitute, if desired, two pieces 2 in. x 4 in., hardwood. Nail bottom piece to floor with four 30-D nails and top piece to one below with four 40-D nails.
C	2 ea. roll.	4 in. x 6 in., hardwood, length to suit. For rolls 20,000 lbs. and over, secure each with two bolts $\frac{3}{4}$ in. in dia., with washers, through floor and Items "G". For rolls under 20,000 lbs., substitute, if desired, two pieces 2 in. x 4 in., hardwood. Nail bottom piece to floor with two 30-D nails and top piece to one below with two 40-D nails.
D	8 ea. roll.	4 in. x 4 in. x 12 in., hardwood, wedge-shaped. Secure to floor with two 40-D nails.
E	2 ea. roll.	6 in. wide, 36 in. long, hardwood, high enough to completely fill space between floor and bearing of roll. For rolls 20,000 lbs. and over, secure each with two bolts $\frac{3}{4}$ in. in dia., with washers, through floor and Items "G". For rolls under 20,000 lbs., toe-nail to floor and to each other with four 40-D nails.
F	2 ea. Item "E".	4 in. x 4 in. x 12 in., hardwood, wedge-shaped. Secure to Items "E" with two 40-D nails.
G	As required.	4 in. x 4 in. x 18 in., hardwood, or $\frac{1}{2}$ in. x 4 in. x 18 in. plate.

See General Rules 4, 5, 9, 14 and 15 for further details.

MILL ROLLS LENGTHWISE, WITH HIGH TENSION BANDS—FLAT OR GONDOLA CARS

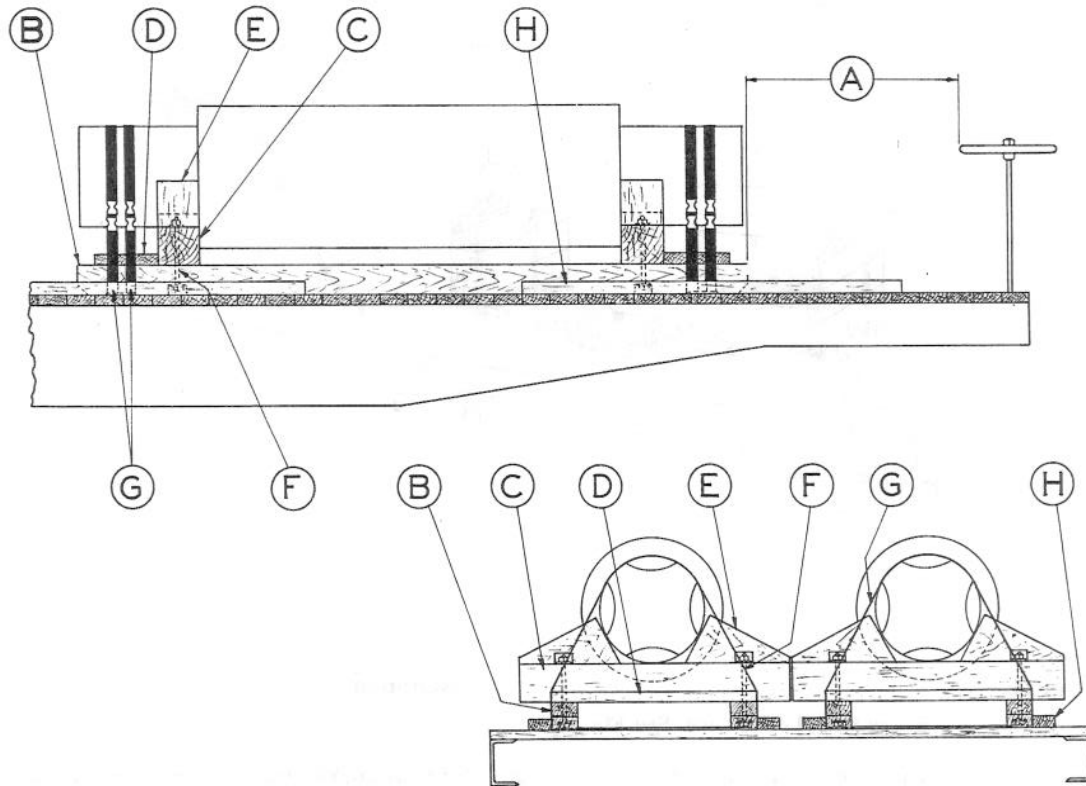

Item	No. of Pcs.	Description
A		Brake wheel clearance. See Fig. 2.
B	2	4 in. wide x 5 in. high, hardwood, long enough to provide full bearing of Items "D" and spaced not less than height of load from floor. Notch to prevent bands from contacting floor. Bevel ends.
C	2	6 in. x 6 in., hardwood, to extend about 3 in. beyond Items "B". When weight exceeds 25,000 lbs., increase dimensions proportionately.
D	2	2 in. x 10 in., long enough to extend to outside of Items "B". Nail to Items "B" with four 30-D nails, each end.
E	4	Wedge shaped blocks, 6 in. x 6 in. x 16 in., hardwood. Nail to Items "C" with six 40-D nails.
F	4	5/8 in. dia. bolt, with washers and nuts countersunk at bottom of Items "B".
G	4	2 in. x .050 in. bands. Locate over neck of rolls. Place suitable protection under bands to prevent damage to finished rolls.
H	4	2 in. x 4 in., 1/3 the length of and extending 3 ft. beyond each end of Items "B". Nail to floor with one 30-D nail to each lineal foot.

See General Rules 4, 5, 9, 14 and 15 for further details.

Sec. 2—Fig. 47

ROUND, HEXAGON, OCTAGON AND CORRUGATED INGOTS—LENGTHWISE—GONDOLA CARS

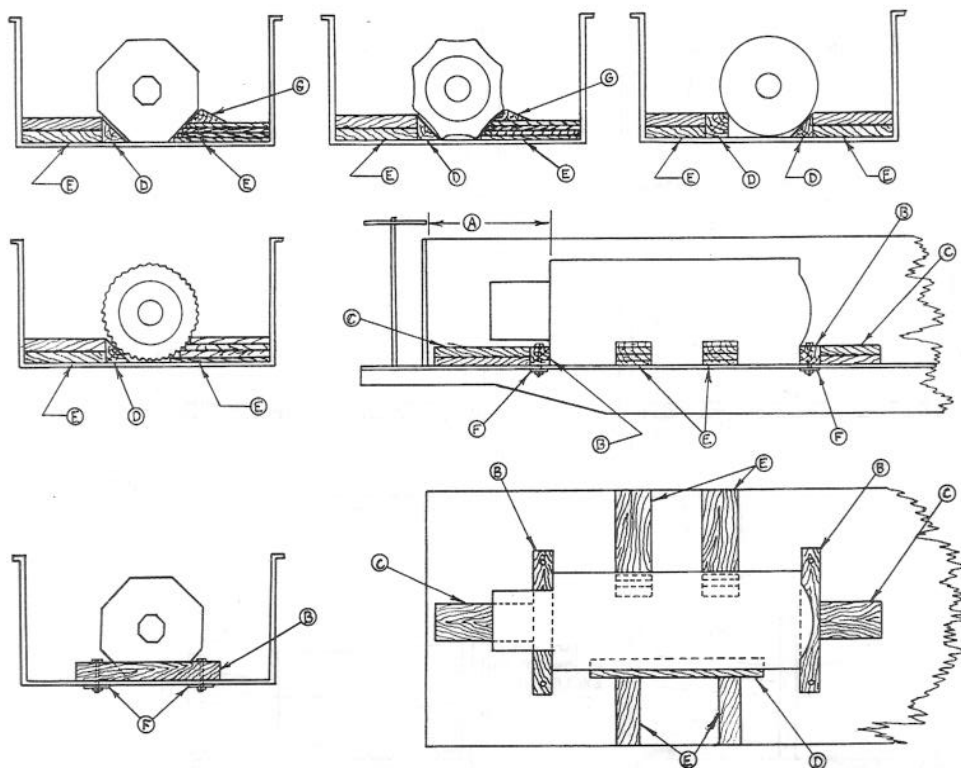

Item	No. of Pcs.	Description
A		Brake wheel clearance. See Fig. 2.
B	2 per ingot	4 in. x 6 in., hardwood, length to suit, secured with two bolts, 3/4 in. diameter, with washers, through floor and Items "F". Not required for ingots weighing less than 50,000 pounds.
C	4 per ingot.	2 in. x 8 in., long enough to permit 24 in. of nailing space beyond overall length of ingot. Locate against ingot or against Item "B", when used, and directly in center line of ingot. Nail bottom piece to floor with eight 40-D nails and the top piece to the one below with eight 40-D nails. Each may be substituted with two pieces 2 in. x 4 in., placed side by side, and each secured to floor with four 40-D nails and two pieces 2 in. x 4 in. on top, each secured to the one below with four 40-D nails. Secure with four bolts, 3/4 in. dia., with washers, through floor and Items "F" when steel floored cars are used.
D	2 per ingot	4 in. x 4 in., hardwood, length equal to 2/3 length of ingot. Toe-nail to floor with 40-D nails. Must be cut to fit contour of hexagon or corrugated ingots. Not required when Items "E" are built up to fit contour of ingot. Toe-nail to Items "E" when steel floored cars are used.
E	4 per ingot	4 in. x 4 in., hardwood, extending from Item "D" to side of car. Nail to floor with five 60-D nails. Each may consist of four 2 in. x 8 in. Nail the bottom piece to floor with four 30-D nails and top pieces to the one below with four 30-D nails. When Items "D" are not used each Item "E" must contact ingot and side of car. Item "G" must be used when height of Items "E" does not fill space between floor of car and contour of hexagon ingots. Secure with two bolts, 3/4 in. dia., with washers, through floor and Items "F" when steel floored cars are used.
F	2 ea. Item "B"	4 in. x 4 in. x 18 in., hardwood, or 1/2 in. x 4 in. x 18 in. plate.
G	4	4 in. x 4 in. x 12 in., hardwood, wedge-shaped. Locate on top of Items "E" and against ingot. Nail to Items "E" with four 40-D nails. Required only when the height of Items "E" does not fill space between floor of car and contour of ingots.

Items "D" and "E" required only on sides of ingots next to car sides when two or more are placed side by side.

Ingots of equal weight, each weighing 13,000 pounds or less, may be loaded against opposite car sides. When so loaded, use one Item "D" on side nearest center of car and Items "E", long enough to fill space between Items "D".

See General Rules 4, 5, 9, 14 and 15 for further details.

Sec. 2—Fig. 48

SLABS, LENGTHWISE—GONDOLA CARS

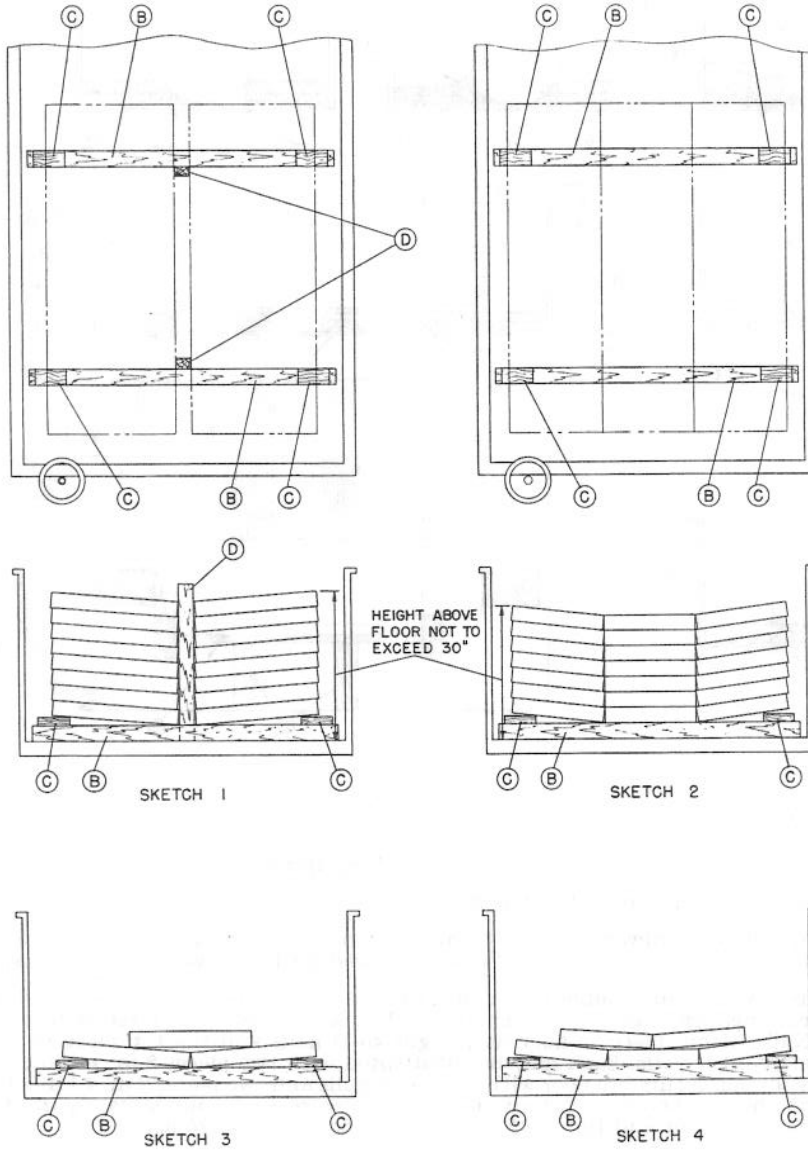

Item	No. of Pcs.	Description
A		Brake wheel clearance. See Fig. 2.
B	2 per pile	4 in. x 4 in., hardwood, length about equal to width of car, locate about one-fifth from each end of pile.
C	2 ea. Item "B"	2 in. x 4 in. x 18 in., hardwood, nailed to Item "B" with four 20-D nails. Locate so edge of slab is approximately in center of strip.
D	1 ea. Item "B"	2 in. x 4 in., hardwood, length equal to height of pile, nail to center of Item "B" with three 30-D nails. Not required for loads per Sketch No. 2. Use optional.

See General Rules 4, 5, 9 and 14 for further details.

Sec. 2—Fig. 49

SLABS, LENGTHWISE—GONDOLA CARS

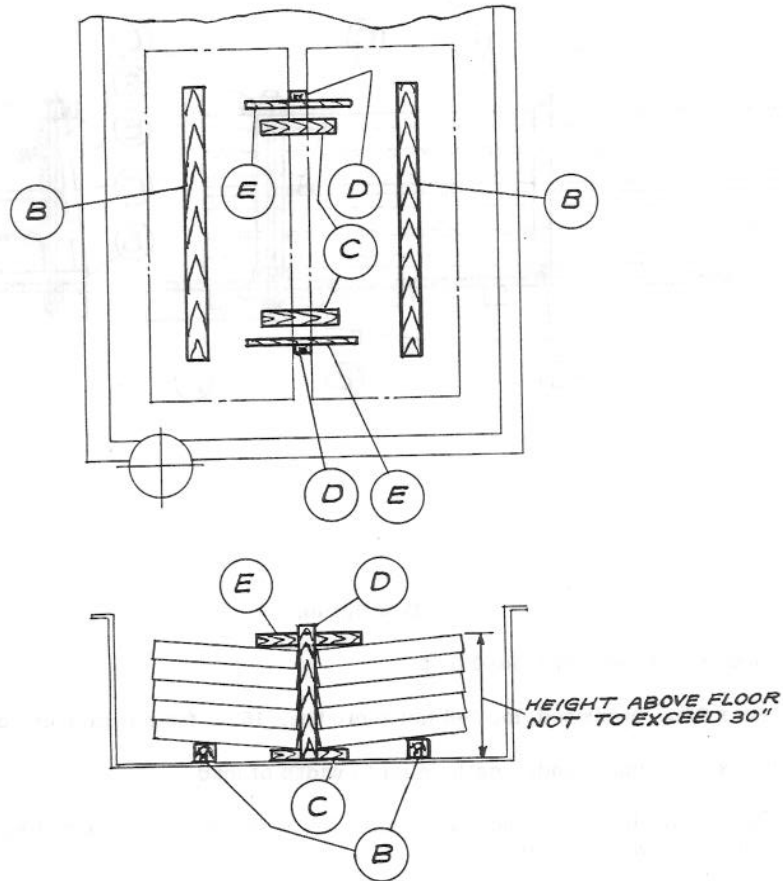

Item	No. of Pcs.	Description
A		Brake wheel clearance. See Fig. 2.
B	2	4 in. x 4 in., hardwood, length approximately equal to length of pile. Locate one about $\frac{1}{3}$ the width of slab from each outer edge of pile.
C	2	2 in. x 2 in. x 22 in., hardwood, crosswise of car directly over center sills. Use optional.
D	2	Vertical separators, 2 in. x 4 in., hardwood, length equal to height of pile. Use optional.
E	1 ea. Item "D"	1 in. x 4 in. x 24 in., nailed to Item "D". Use Optional.

See General Rules 4, 5, 9 and 14 for further details.

Sec. 2—Fig. 50

LARGE GIRDERS, FLATWISE—FLAT CARS

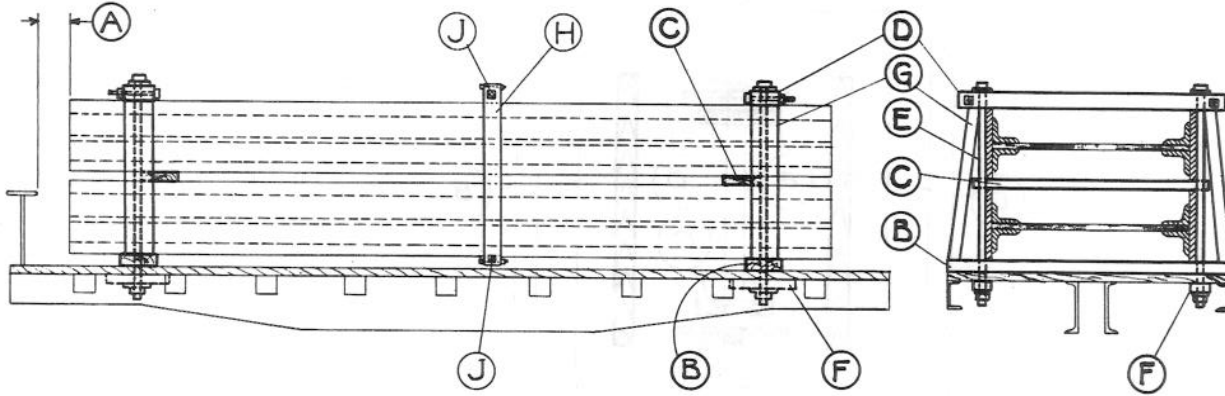

Item	No. of Pcs.	Description
A		Brake wheel clearance. See Fig. 2.
B	2	3 in. x 8 in., hardwood, located not more than 18 in. from center line of bolster.
C	2 ea. tier	2 in. x 8 in., hardwood, length equal to width of load.
D	2	4 in. x 6 in., hardwood, length to suit. Use $\frac{1}{2}$ in. dia. bolt, crosswise, with washers, at each end to prevent splitting.
E	2 ea. Item "D"	1 in. dia. rods, with nuts and washers, long enough to extend through Items "D", floor and Items "F".
F	1 ea. Item "E"	4 in. x 4 in. x 18 in., hardwood, or $\frac{1}{2}$ in. x 4 in. x 18 in. plate.
G	4	4 in. x 6 in., for loads 24 in. high or over. Not required for structural material and plates, 24 in. wide or more, unless the height exceeds the width of the individual pile in the load.
H	2	6 in. x 8 in., hardwood, length to suit, located at center of load. Use $\frac{1}{2}$ in. dia. bolt, crosswise, with washers, at each end to prevent splitting.
J	2	1 in. dia. rod with nuts and washers, long enough to extend through top and bottom of Items "H".

Items "H" and "J" not required when substituted with two 2 in. x .050 in. high tension bands, located as close together as possible.

Items "H" and "J" not required for piles 25 ft. long or less.

See General Rules 4, 5, 9 and 15 for further details.

Sec. 2—Fig. 51

GIRDERS, VERTICALLY—FLAT OR GONDOLA CARS

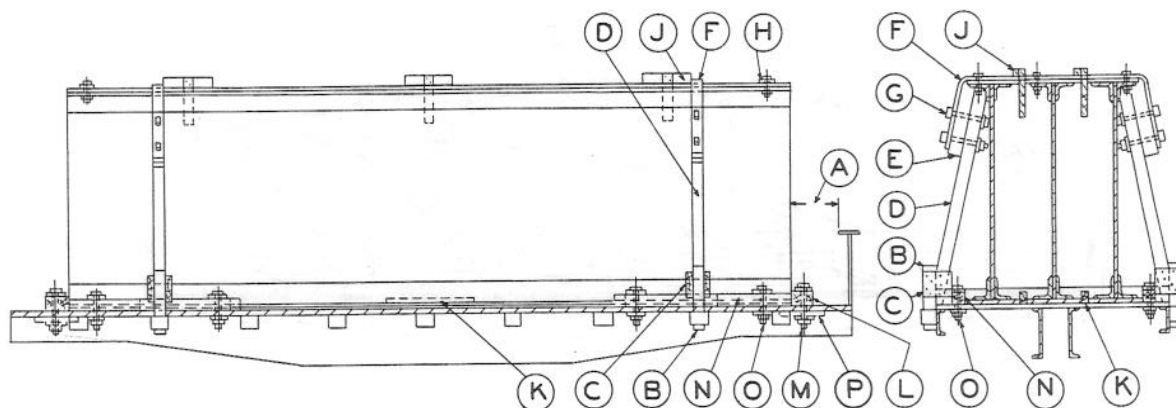

Item	No. of Pcs.	Description
A		Brake wheel clearance. See Fig. 2.
B	4	Stakes, 4 in. x 5 in., hardwood, length to suit.
C	8	2 in. x 10 in., hardwood.
D	4	4 in. x 6 in., hardwood.
E	4	To suit.
F	2	$\frac{3}{8}$ in. x 4 in. plate, length to suit.
G	8	$\frac{3}{4}$ in. dia. bolt, with washers.
H	2	$\frac{3}{8}$ in. x 4 in. plate, secured to each girder. Dia. of bolt to suit hole in girder.
J	6	2 in. x 4 in. x 16 in., "T" blocks.
K	6	2 in. x 4 in. x 3 ft., nailed to floor.
L	2	6 in. x 8 in., hardwood.
M	6	$\frac{3}{4}$ in. dia. bolt, with washers, through Items "L" and "P".
N	4	4 in. x 4 in. x 6 ft., hardwood.
O	8	$\frac{3}{4}$ in. dia. bolt, with washers.
P	6	4 in. x 4 in. x 18 in., hardwood, or $\frac{1}{2}$ in. x 4 in. x 18 in. plate.

For gondola loading, substitute in lieu of Items "B", "C", "N" and "O"; four pieces, 2 in. x 8 in., hardwood, laterally between bottom flange of outside girder and car side near each Item "D", nailed to floor. Also, four pieces, 2 in. x 8 in., hardwood, laterally between web of outside girder and car sides, nailed to top side of the above mentioned 2 in. x 8 in. pieces. All other bracing to be same as for flat cars.

See General Rules 4, 5, 9, 10, 14 and 15 for further details.

Sec. 2—Fig. 52

WHOLE OR SECTIONAL ROOF TRUSSES, ETC.—GONDOLA CARS

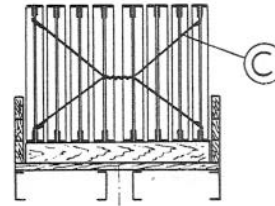
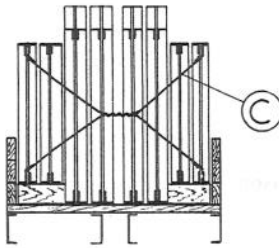
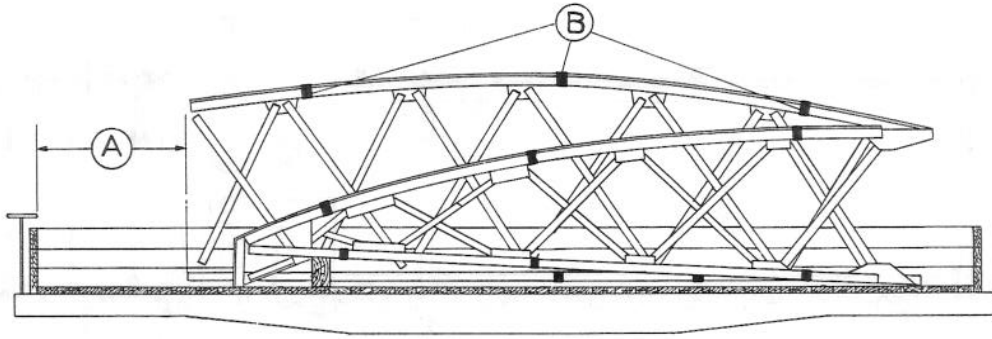

Item	No. of Pcs.	Description
A		Brake wheel clearance. See Fig. 2.
B	12	1¼ in. x .035 in., high tension bands. Locate as follows: 3 around top and 3 around bottom of inside sections; 3 around top and 3 around bottom of outside sections, tying all sections together, as shown.
C	4	8 strands, No. 11 gage wire, or 2 strands, No. 8 gage high tension wire, or 1 strand, 1¼ in. x .035 in. high tension band. Interlace common wire and twist taut. High tension bands and wires to be tensioned and sealed, or twist tied, respectively.

Stakes, where used to facilitate loading, must be secured so as to prevent displacement.

See General Rules 4, 5, 10 and 15 for further details.

Sec. 2—Fig. 53

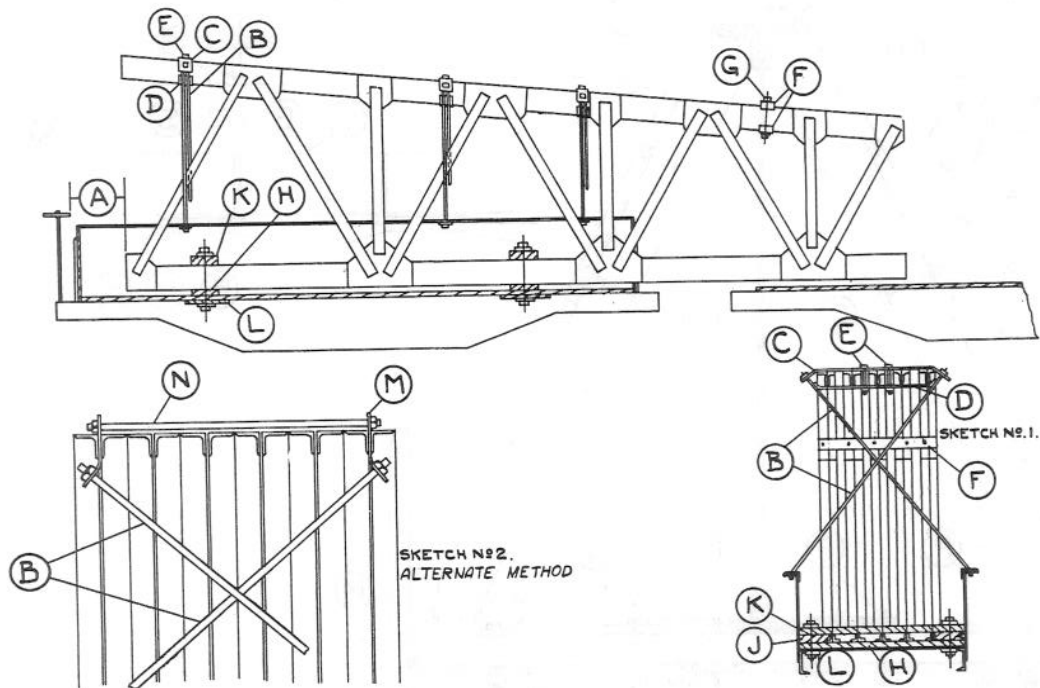
OPEN GIRDERS, WHOLE OR HALF-ROOF TRUSSES, ETC. LOAD ON ONE CAR, WITH OR WITHOUT OVERHANGS—
FLAT OR GONDOLA CARS

Item	No. of Pcs.	Description
A		Brake wheel clearance. See Fig. 2.
B	Loads 5 ft. high or less above top of car sides 2 pr. 3 pr.	$\frac{3}{4}$ in. dia. rods, loads less than 20,000 lbs. $\frac{3}{4}$ in. dia. or two pr. $\frac{7}{8}$ in. dia. rods for loads weighing 20,000 lbs. and less than 30,000 lbs.
	Loads over 5 ft. high above top of car sides 2 pr. 3 pr.	$\frac{7}{8}$ in. dia. rods for loads weighing 30,000 lbs. or less. 1 in. dia. rods for loads weighing over 30,000 lbs. When rods pass through stake pockets, use $\frac{1}{2}$ in. x 4 in. x 10 in. plates underneath stake pockets. Locate rods as shown so as to equalize strain.
C	1 ea. pr. Items "B"	$\frac{3}{4}$ in. x 3 in. plates, length to suit. Not required when Items "M" and "N" are used.
D	1 ea. Item "C"	$\frac{3}{8}$ in. x 3 in. plates, length to suit. Not required when Items "M" and "N" are used.
E	2 ea. Item "D"	$\frac{5}{8}$ in. dia. bolts or rods, through Items "C" and "D". Not required when Items "M" and "N" are used.
F	2 ea. overhang	$\frac{3}{8}$ in. x 2 in. plates, length to suit. Not required when overhang is 10 ft. long or less.
G	1 ea. girder or truss	$\frac{1}{2}$ in. dia. bolts, long enough to pass through Items "F".
H	Load 50 ft. long or less, 2; Load over 50 ft. long, 3	4 in. x 6 in., hardwood, length to suit. Secure each with two bolts $\frac{7}{8}$ in. dia., with washers, through Items "H", "J", "K", "L" and floor.
J	2 ea. Item "H"	6 in. wide, height and length to suit.
K	1 ea. Item "H"	4 in. x 6 in., hardwood, length to suit. Use one bolt, $\frac{1}{2}$ in. dia., crosswise, with washers, at each end to prevent splitting.
L	2 ea. Item "H"	4 in. x 4 in. x 18 in., hardwood, or $\frac{1}{2}$ in. x 4 in. x 18 in. plates.
M	2 ea. pr. Items "B"	$\frac{3}{8}$ in. x 6 in. steel plates, length to suit. Not required when Items "C", "D" and "E" are used.
N	1 ea. pr. Items "M"	$\frac{5}{8}$ in. dia. rod, length to suit. Not required when Items "C", "D" and "E" are used.

Place additional blocking underneath load if liable to damage by deflection.
Apply blocking to separate material liable to damage by contact.
See General Rules 4, 5, 6, 7, 8, 9, 12, 14, 15 and 16 for further details.

LATTICE GIRDERS, PLATE GIRDERS, COLUMNS, ETC.—SINGLE CAR, OVERHANGING BOTH ENDS OF FLAT OR GONDOLA CARS

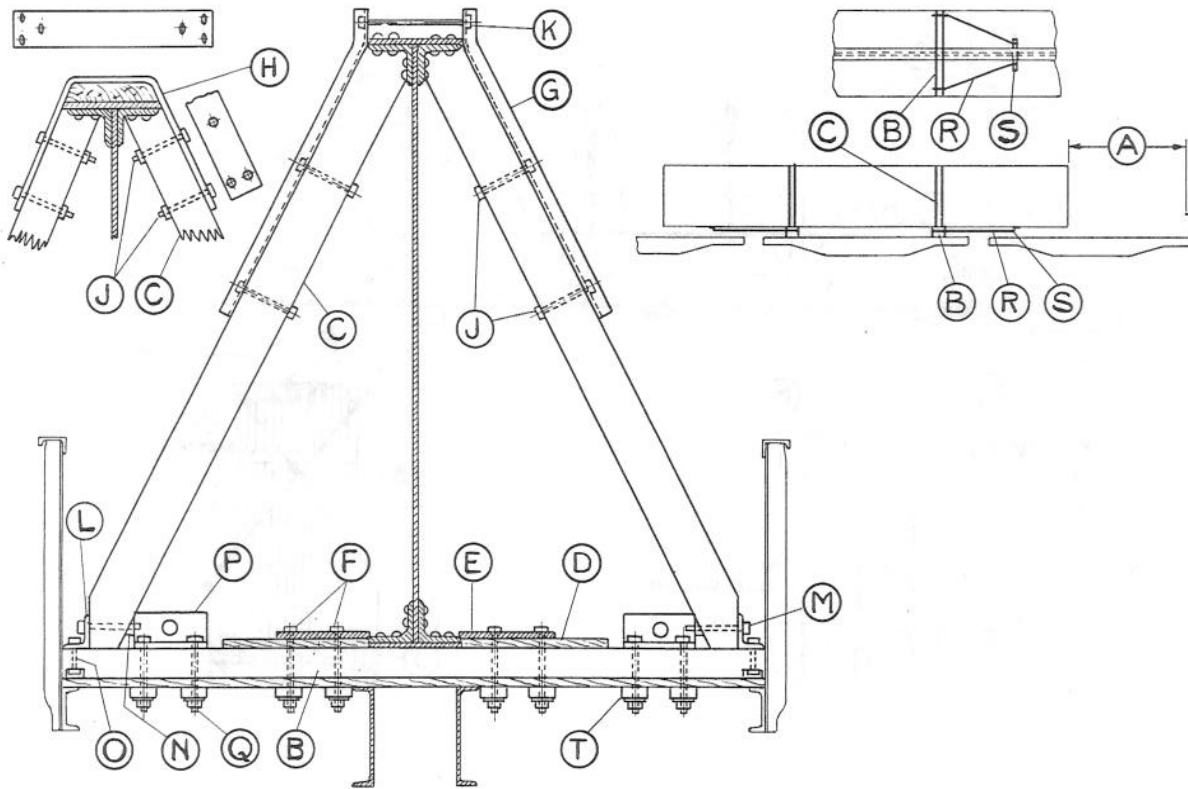

Item	No. of Pcs.	Description
A		Brake wheel clearance. See Fig. 2.
B	2	8 in. wide, hardwood, 36,000 lbs. or less. 10 in. wide, over 36,000 lbs. to 73,000 lbs. per bolster, inclusive, length equal to width of car, high enough to provide 4 in. clearance between load and floor or end gate of idler cars.
C	4	6 in. x 8 in., hardwood, 30,000 lbs. or less. 6 in. x 10 in., over 30,000 lbs. to 72,000 lbs., inclusive. 6 in. x 12 in., over 72,000 lbs. to 115,000 lbs., inclusive. 8 in. x 12 in., over 115,000 lbs. to 146,000 lbs., inclusive.
D	4	10 in. x 2 ft., hardwood, thickness $\frac{1}{8}$ in. less than flange of girder.
E	4	$\frac{3}{4}$ in. x 6 in. x 1 ft. 4 in., plate, 30,000 lbs. or less. 1 in. x 6 in. x 1 ft. 4 in., plate, over 30,000 lbs. to 115,000 lbs., inclusive.
F	12	$1\frac{1}{8}$ in. x 6 in. x 1 ft. 4 in., plate, over 115,000 lbs. to 146,000 lbs., inclusive. $\frac{3}{4}$ in. dia., bolts, 72,000 lbs. or less. $\frac{7}{8}$ in. dia., bolts, 72,000 lbs. to 146,000 lbs., inclusive.
G	4	6 in. x 3 ft., channels or angles; or per Item "H".
H	2	$\frac{1}{2}$ in. x 6 in., plate, length to suit; or per Items "G".
J	8	$\frac{3}{4}$ in. dia., bolts, with washers, when Items "G" are used.
K	12	$\frac{3}{4}$ in. dia., bolts, with washers, when Items "H" are used.
L	4	$\frac{7}{8}$ in. dia., bolts, 72,000 lbs. or less. 1 in. dia., bolts, over 72,000 lbs. to 146,000 lbs., inclusive.
M	4	4 in. x 3 in. x $\frac{3}{8}$ in. angle, length to suit.
N	8	$\frac{3}{4}$ in. dia., bolts.
O	4	$\frac{1}{4}$ in. x 3 in., plate, length to suit.
P	8	$\frac{3}{4}$ in. dia., bolts, with washers.
Q	4	5 in. x 3 in. angles, length to suit. May be omitted on bolsters 6 in. thick or over when bored for Items "R".
R	8	$\frac{3}{4}$ in. dia., bolts, 72,000 lbs. or less. $\frac{7}{8}$ in. dia., bolts, over 72,000 lbs. to 146,000 lbs., inclusive.
S	4	1 in. dia., rod, 30,000 lbs. or less. $1\frac{1}{8}$ in. dia., rod, over 30,000 lbs. to 72,000 lbs., inclusive. $1\frac{1}{4}$ in. dia., rod, over 72,000 lbs. to 115,000 lbs., inclusive. $1\frac{1}{2}$ in. dia., rod, over 115,000 lbs. to 146,000 lbs., inclusive.
T	2	$3\frac{1}{2}$ in. x $3\frac{1}{2}$ in. x $\frac{3}{8}$ in. angle, length to suit, bolted to girder.
	16 Cleats or 20 Plates	4 in. x 4 in. x 18 in., hardwood, or $\frac{1}{2}$ in. x 4 in. x 18 in. plates.

Material must be suitably protected to prevent becoming permanently distorted.
See General Rules 4, 5, 6, 7, 8, 9, 12, 15 and 16 for further details.

Sec. 2—Fig. 55

LATTICE GIRDERS, PLATE GIRDERS, COLUMNS, ETC.—SINGLE CAR, OVERHANGING BOTH ENDS OF FLAT OR GONDOLA CARS

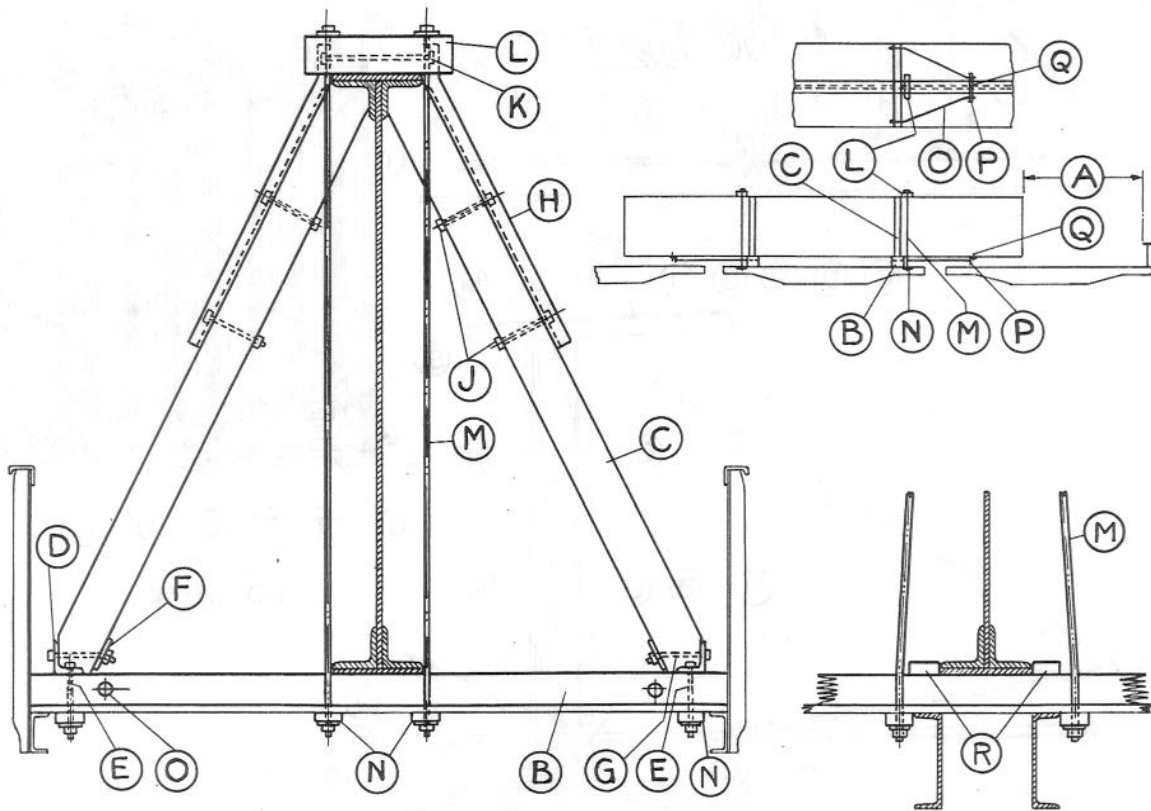

Item	No. of Pcs.	Description
A		Brake Wheel Clearance. See Fig. 2.
B	2	8 in. wide, hardwood, 36,000 lbs. or less, per bolster. 10 in. wide, over 36,000 lbs. to 73,000 lbs. per bolster, inclusive, length equal to width of car, high enough to provide 4 in. clearance between load and floor or end gates of idler cars.
C	4	6 in. x 8 in., hardwood, 30,000 lbs. or less. 6 in. x 10 in., over 30,000 lbs. to 72,000 lbs., inclusive. 6 in. x 12 in., over 72,000 lbs. to 115,000 lbs., inclusive. 8 in. x 12 in., over 115,000 lbs. to 146,000 lbs., inclusive.
D	4	4 in. x 3 in. x $\frac{3}{8}$ in. angle, length to suit.
E	8	$\frac{3}{4}$ in. dia., bolts.
F	4	$\frac{1}{4}$ in. x 3 in., plate, length to suit.
G	8	$\frac{3}{4}$ in. dia., bolts.
H	4	6 in. x 3 ft. channels or angles.
J	8	$\frac{3}{4}$ in. dia., bolts, with washers.
K	4	$\frac{3}{4}$ in. dia., bolts.
L	2	6 in. x 8 in., hardwood, length to suit.
M	4	1 in. dia., rod, with washers, through Item "L" and "N" when width at base of girder is such that Item "M" will come in contact with car center sills, they should be placed as close as possible thereto, bottom flange of girder to be blocked as per Items "R".
N	8 cleats or 12 plates	4 in. x 4 in. x 18 in., hardwood, or $\frac{1}{2}$ in. x 4 in. x 18 in. plate.
O	4	1 in. dia., rod, 30,000 lbs. or less. $1\frac{1}{8}$ in. dia., rod, over 30,000 lbs. to 72,000 lbs., inclusive. $1\frac{1}{4}$ in. dia., rod, over 72,000 lbs.
P	2	$3\frac{1}{2}$ in. x $3\frac{1}{2}$ in. x $\frac{3}{8}$ in. angle, length to suit, bolted to girder.
Q	8	Bolts $\frac{1}{6}$ in. less than dia. of hole in girder.
R	4	2 in. x 6 in. x 10 in., hardwood, length equal to width of Item "B", secured with five 30-D nails.

Material must be suitably protected to prevent becoming permanently distorted.

See General Rules 4, 5, 6, 7, 8, 9, 12, 14, 15 and 16 for further details.

ROOF TRUSSES, VERTICALLY, PIVOTED BOLSTERS—TWO FLAT OR GONDOLA CARS

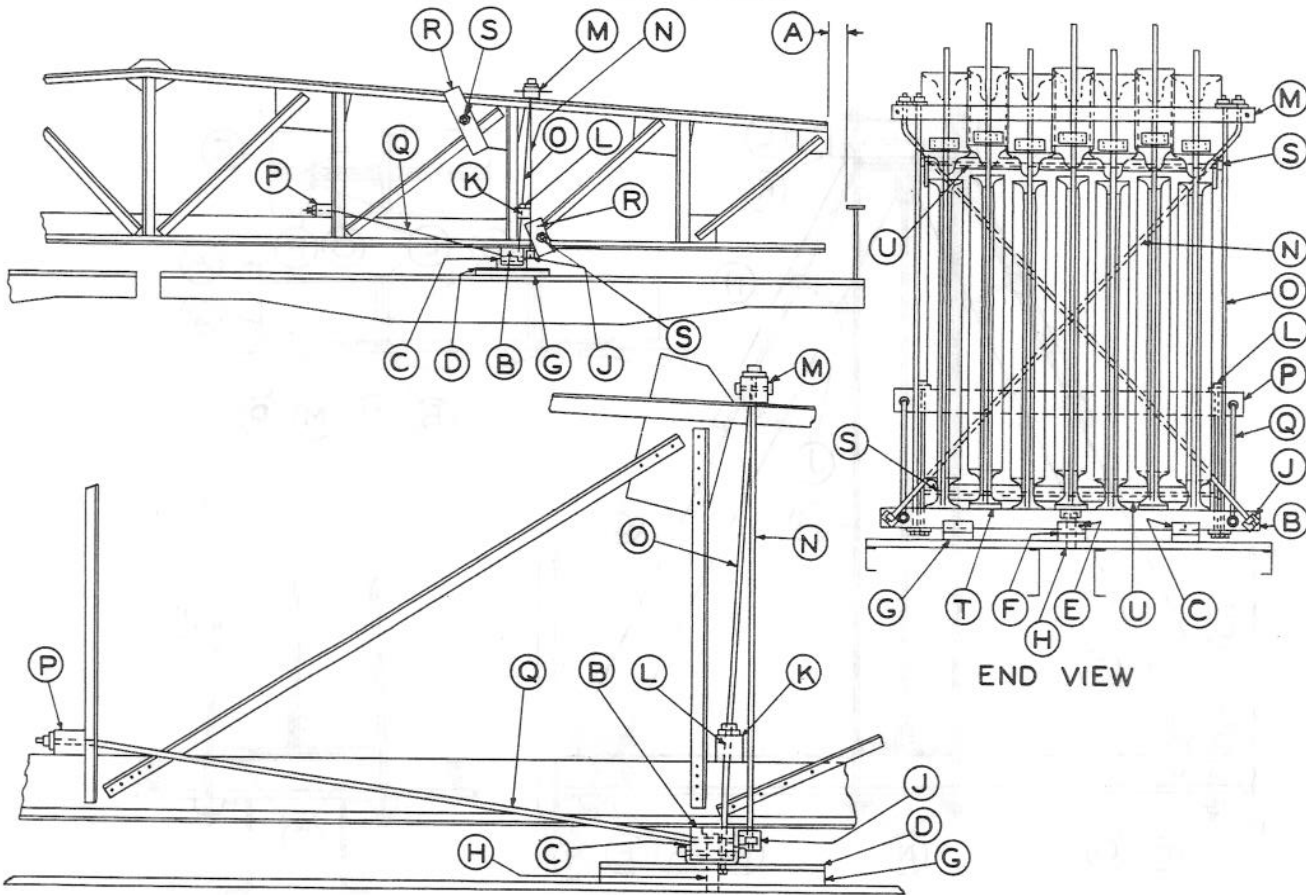

Item	No. of Pcs.	Description
A		Brake wheel clearance. See Fig. 2.
B	2	8 in. x 10 in., hardwood, loads less than 15,000 lbs., per bolster.
C	2 per bolster	10 in. x 14 in., hardwood, loads 15,000 lbs. to 36,000 lbs., per bolster.
D	4	$\frac{1}{4}$ in. x 12 in. x 1 ft. 3 in., loads less than 15,000 lbs., per bolster. $\frac{1}{4}$ in. x 12 in. x 1 ft. 7 in., loads 15,000 lbs. to 36,000 lbs., per bolster. Secure each with one bolt, $\frac{5}{8}$ in. dia.
E	1 per bolster	$\frac{3}{8}$ in. x 12 in. x 4 ft. 6 in., plate, secured with four bolts, $\frac{3}{4}$ in. dia., with washers, through Item "G" and floor.
F	1 per bolster	$\frac{1}{4}$ in. x 12 in. x 1 ft. 3 in., plate, loads less than 15,000 lbs., per bolster.
G	3 per bolster	$\frac{1}{4}$ in. x 12 in. x 1 ft. 7 in., plate, loads 15,000 lbs. to 36,000 lbs., per bolster. Secure with one bolt, $\frac{5}{8}$ in. dia.
H	1 per bolster	$\frac{1}{2}$ in. x 12 in. x 12 in., plate.
J	2 per bolster	2 $\frac{1}{2}$ in. dia., pin, with head, long enough to rest on center sill cover plate.
K	1 per bolster	6 in. x 6 in. x $\frac{1}{2}$ in. angle, secured with one bolt, 1 in. dia., loads less than 30,000 lbs.; one bolt, $1\frac{1}{8}$ in. dia., loads 30,000 lbs. to 72,000 lbs.
L	2 per bolster	6 in. x 6 in., hardwood, length to suit. Use one bolt, $\frac{1}{2}$ in. dia., crosswise, with washers, at each end to prevent splitting.
M	1 per bolster	1 in. dia., rod.
N	2 per bolster	6 in. x 6 in., hardwood, loads less than 30,000 lbs.
O	2 per bolster	6 in. x 8 in., hardwood, loads 30,000 lbs. to 72,000 lbs., length to suit.
P	1 per bolster	Use one bolt, $\frac{1}{2}$ in. dia., crosswise, with washers, at each end to prevent splitting.
Q	2 per bolster	1 in. dia., loads less than 30,000 lbs., $1\frac{1}{8}$ in. dia., loads 30,000 to 72,000 lbs., length to suit.
R	4 per bolster	$1\frac{1}{8}$ in. dia., rod.
S	2 per bolster	Plates to suit.
T	3 per bolster	1 in. dia., rod.
U	12 per bolster	Wood fillers to suit.

Trusses, may be loaded vertically on pivoted bolsters if clamped together near bolsters and spacing pieces used to make a unit load.

For length of slotted center pin hole see Fig. 5.

For trusses more than 50 ft. long, if necessary to pass a curve of more than 20 degrees curvature, nuts on one bolster should be loosened to allow trusses to shift on bolster. After curve is passed all nuts must be tightened.

Items "K" and "M" must rest on each truss or have suitable blocks secured between them and trusses.

Item "L" must bear against bottom flange and Item "O" against top flange of outside trusses.

Grease center-plates and side-bearings before bolsters are placed in position.

See General Rules 4, 5, 6, 7, 9, 12, 15, 18 and 21 for further details.

THIS PAGE WAS LEFT BLANK INTENTIONALLY

GIRDERS, VERTICALLY ON PIVOTED BOLSTERS—FLAT OR GONDOLA CARS

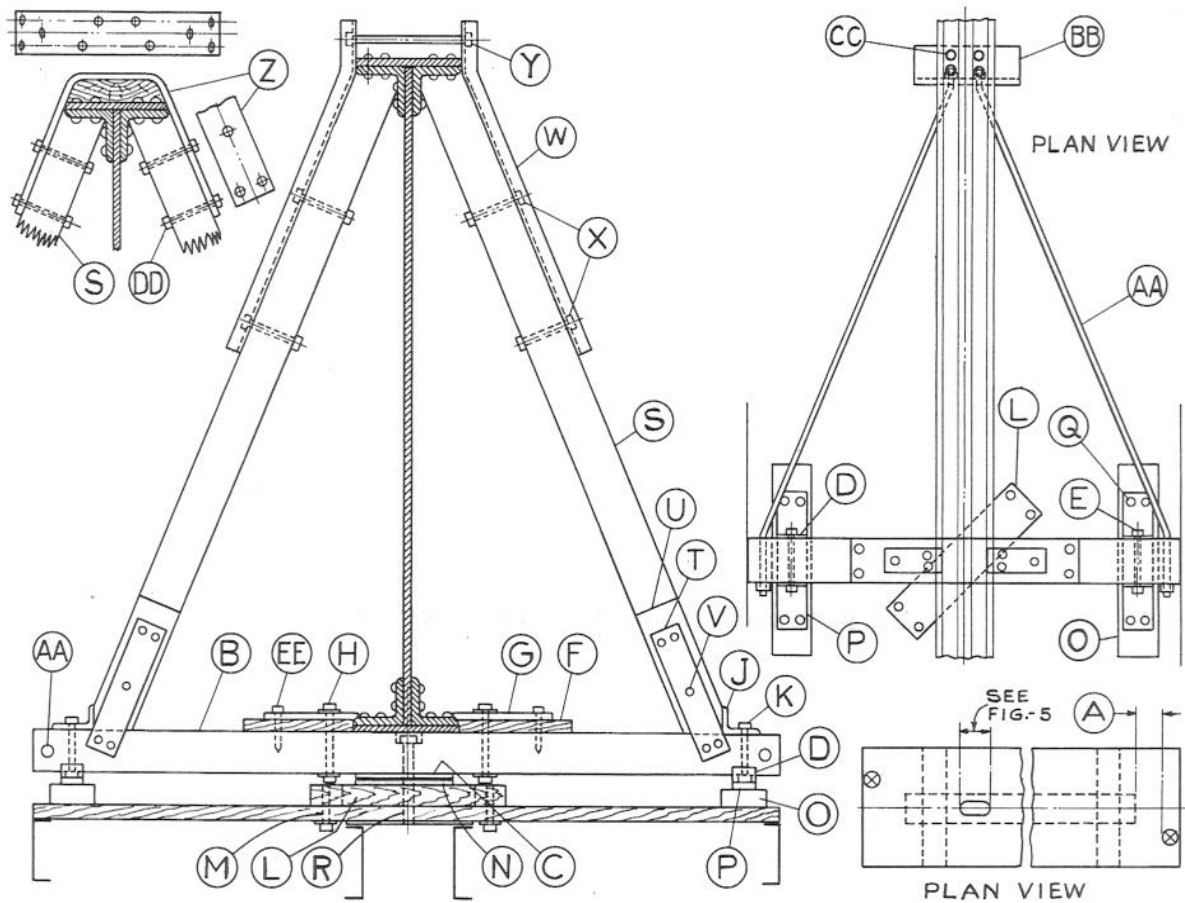

Sec. 2—Fig. 57

GIRDERS, VERTICALLY ON PIVOTED BOLSTERS—FLAT OR GONDOLA CARS

Description	Item	No. of Pcs.	Loads weighing 20,000 lbs. or less, per bolster	Loads weighing over 20,000 lbs. and not exceeding 40,000 lbs. per bolster	Loads weighing over 40,000 lbs. and not exceeding 60,000 lbs. per bolster	Loads weighing over 60,000 lbs. and not exceeding 100,000 lbs. per bolster
Brake wheel clearance, See Fig. 2.....	A					
Bolster.....	B	2	8"x10"x9'6"	10"x12"x9'6"	12"x14"x9'6"	14"x16"x9'6"
Center-plate, top.....	C	2	3/8"x12"x12"	3/8"x12"x12"	3/8"x12"x12"	3/8"x12"x12"
Side-bearing plate, top (bent).....	D	4	1/4"x6"x1'3"	1/4"x6"x1'7"	1/4"x6"x1'9"	3/8"x6"x2'1"
Bolts for side-bearing plates, top.....	E	4	5/8" dia.	5/8" dia.	5/8" dia.	5/8" dia.
Bolster-side stops.....	F	4	1"x10"x2'	1"x10"x2'	1"x10"x2'	1"x10"x2'
Flange clamps.....	G	4	3/4"x6"x1'4"	1"x6"x1'4"	1"x6"x1'4"	1 1/8"x6"x1'4"
Bolts for flange clamps.....	H	8	3/4" dia.	3/4" dia.	7/8" dia.	7/8" dia.
Strut angles.....	J	4	5"x3 1/2"x3 3/8"x 9 3/4" long	5"x3 1/2"x3 3/8"x 13 1/2" long	5"x3 1/2"x3 3/8"x 15" long	5"x3 1/2"x3 3/8"x 18" long
Bolts for strut angles.....	K	8	3/4" dia.	3/4" dia.	7/8" dia.	7/8" dia.
Center-plate backing.....	L	2	3"x12"x5'	3"x12"x5'	3"x12"x5'	4"x12"x5'
Bolts for center-plate backing.....	M	8	3/4" dia.	3/4" dia.	3/4" dia.	3/4" dia.
Center-plate, bottom.....	N	2	3/8"x12"x12"	3/8"x12"x12"	3/8"x12"x12"	1/2"x12"x12"
Side-bearing, backing.....	O	4	3"x10"x5'	3"x10"x5'	3"x10"x5'	4"x10"x5'
Side-bearing plate, bottom.....	P	4	3/8"x6"x3'6"	3/8"x6"x3'6"	3/8"x6"x4'	3/8"x6"x4'
Bolts for side-bearing plate; bottom.....	Q	16	3/4" dia.	3/4" dia.	3/4" dia.	3/4" dia.
Center-pin, with head.....	R	2	2 1/2" dia.	2 1/2" dia.	2 1/2" dia.	2 1/2" dia.
Struts.....	S	4	*6"x8"	*6"x10"	*6"x12"	*8"x12"
Strut straps.....	T	8	3/8"x5"x1'6"	3/8"x5"x1'6"	3/8"x5"x1'6"	1/2"x5"x1'6"
Strut strap fillers.....	U	8	1"x6"x1'6"	2"x6"x1'6"	2"x6"x1'6"	4"x8"x1'6"
Bolts for strut straps.....	V	20	3/4" dia.	3/4" dia.	3/4" dia.	3/4" dia.
Strut top irons.....	W	4	6"x3' chan-nels, or angles	6"x3' chan-nels, or angles	6"x3' chan-nels, or angles	6"x3' chan-nels, or angles
Bolts securing strut top irons.....	X	8	3/4" dia.	3/4" dia.	3/4" dia.	3/4" dia.
Bolts connecting strut top irons.....	Y	4	7/8" dia.	1" dia.	1" dia.	1" dia.
Alternate fastening.....	Z	2	1/2"x6"	1/2"x6"	1/2"x6"	1/2"x6"
Brace rods.....	AA	4	1" dia.	1 1/8" dia.	1 1/4" dia.	1 1/4" dia.
Brace rod angle.....	BB	2	5"x3 1/2"x3 3/8"	5"x3 1/2"x3 3/8"	5"x3 1/2"x3 3/8"	5"x3 1/2"x3 3/8"
Bolts for brace rod angles.....	CC	8	1/16" less than dia. of hole	1/16" less than dia. of hole	1/16" less than dia. of hole	1/16" less than dia. of hole
Bolts for alternate fastenings.....	DD	12	3/4" dia.	3/4" dia.	3/4" dia.	3/4" dia.
Spikes or lag screws.....	EE	12	1/2"x4"	1/2"x4"	1/2"x4"	1/2"x4"

*May be made of two pieces, securely bolted together.

†To be 1/8 in. less than flange of girder.

Items "S", must be neatly fitted and driven into place.

Item "AA", may be attached to girders between bolsters, or to both overhanging ends of girders.

Items "B", made of one piece shall have one 3/4 in. transverse bolt on either side of center pin to prevent splitting. When made of 2 or 3 pieces they shall have at least six 3/4 in. transverse bolts.

Items "L", shall have one 5/8 in. transverse bolt on either side of center pin to prevent splitting.

For length of slotted center pin hole see Fig. 5.

Girders over 8 ft. deep, weighing less than 20,000 lbs. per bolster, shall have bolsters as specified for girders weighing over 20,000 lbs. to 40,000 lbs., per bolster.

Girders more than 50 ft. long, if necessary to pass a curve of more than 20 degrees, nuts on one bolster should be loosened to allow girder to shift on bolster. After curve is passed all nuts must be tightened.

Items "R" must be sufficiently long to rest on center sill cover plate.

All wooden items must be hardwood.

See General Rules 4, 5, 6, 7, 9, 12 and 15 for further details.

GIRDERS, VERTICALLY ON PIVOTED BOLSTERS—FLAT OR GONDOLA CARS

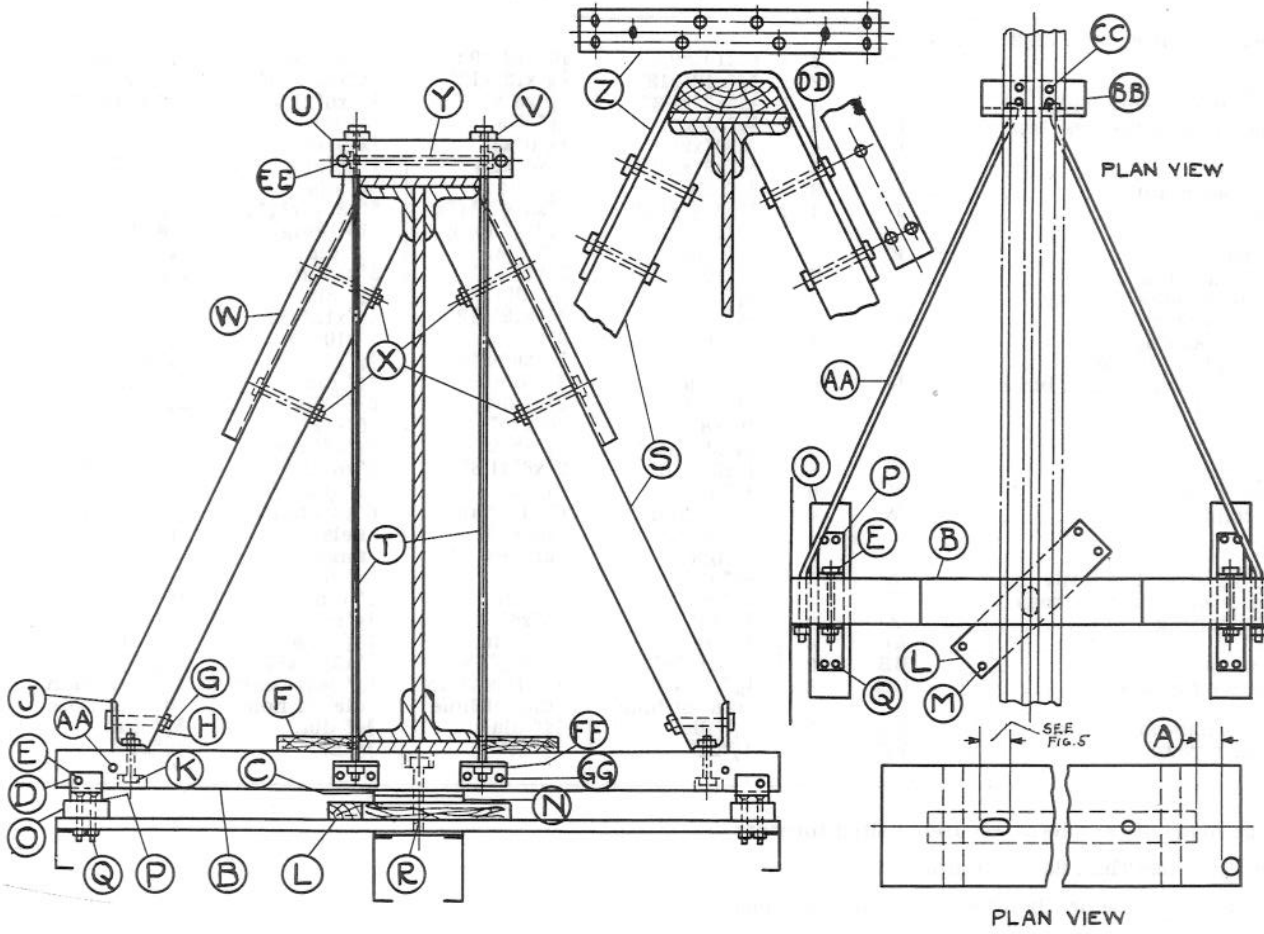

Sec. 2—Fig. 58

GIRDERS, VERTICALLY ON PIVOTED BOLSTERS—FLAT OR GONDOLA CARS

Description	Item	No. of Pcs.	Loads weighing 20,000 lbs. or less per bolster	Loads weighing over 20,000 lbs. and not exceeding 40,000 lbs. per bolster	Loads weighing over 40,000 lbs. and not exceeding 60,000 lbs. per bolster	Loads weighing over 60,000 lbs. and not exceeding 100,000 lbs. per bolster
Brake wheel clearance. See Fig. 2.....	A					
Bolster.....	B	2	8"x10"x9'6"	10"x12"x9'6"	12"x14"x9'6"	14"x16"x9'6"
Center-plate, top.....	C	2	3/8"x12"x12"	3/8"x12"x12"	3/8"x12"x12"	3/8"x12"x12"
Side-bearing plate, top (bent).....	D	4	1/4"x6"x1'3"	1/4"x6"x1'7"	1/4"x6"x1'9"	3/8"x6"x2'1"
Bolts for side-bearing plates, top.....	E	4	5/8" dia.	5/8" dia.	5/8" dia.	5/8" dia.
Bolster side stops.....	F	4	2"x10"x1'6", each secured with 6-30D nails	2"x10"x1'6", each secured with 6-30D nails	2"x10"x1'6", each secured with 6-30D nails	2"x10"x1'6", each secured with 6-30D nails
Bolts securing struts.....	G	4	3/4" dia.	3/4" dia.	3/4" dia.	3/4" dia.
Washers for strut bolts.....	H	4	1/4"x3"x3"	1/4"x3"x3"	1/4"x3"x3"	1/4"x3"x3"
Strut angles.....	J	4	5"x3 1/2"x3 3/8"x 9 3/4" long	5"x3 1/2"x3 3/8"x 13 1/2" long	5"x3 1/2"x3 3/8"x 15" long	5"x3 1/2"x3 3/8"x 18" long
Bolts for strut angles.....	K	8	3/4" dia.	3/4" dia.	3/4" dia.	3/4" dia.
Center-plate backing.....	L	2	3"x12"x5'	3"x12"x5'	3"x12"x5'	4"x12"x5'
Bolts for center-plate backing.....	M	8	3/4" dia.	3/4" dia.	3/4" dia.	3/4" dia.
Center-plate, bottom.....	N	2	3/8"x12"x12"	3/8"x12"x12"	3/8"x12"x12"	3/8"x12"x12"
Side-bearing backing.....	O	4	3"x10"x5'	3"x10"x5'	3"x10"x5'	4"x10"x5'
Side-bearing plate, bottom.....	P	4	3/8"x6"x3'6"	3/8"x6"x3'6"	3/8"x6"x4'	3/8"x6"x4'
Bolts for side-bearing plate, bottom.....	Q	16	3/4" dia.	3/4" dia.	3/4" dia.	3/4" dia.
Center-pin with head.....	R	2	2 1/2" dia.	2 1/2" dia.	2 1/2" dia.	2 1/2" dia.
Struts.....	S	4	*6"x8"	*6"x10"	*6"x12"	*8"x12"
Vertical tie rods.....	T	4	1" dia.	1" dia.	1" dia.	1" dia.
Top tie clamp (hardwood).....	U	2	6"x8"	6"x8"	6"x8"	6"x8"
Vertical tie rod washers.....	V	4	1/4"x4"x4"	1/4"x4"x4"	1/4"x4"x4"	1/4"x4"x4"
Strut top irons.....	W	4	6"x3' chan- nels, or angles	6"x3' chan- nels, or angles	6"x3' chan- nels, or angles	6"x3' chan- nels, or angles
Bolts securing strut top irons.....	X	8	3/4" dia.	3/4" dia.	3/4" dia.	3/4" dia.
Bolts connecting strut top irons.....	Y	4	7/8" dia.	7/8" dia.	1" dia.	1" dia.
Alternate fastening.....	Z	2	1/2"x6"	1/2"x6"	1/2"x6"	1/2"x6"
Brace rods.....	AA	4	1" dia.	1 1/8" dia.	1 1/8" dia.	1 1/4" dia.
Brace rod angles.....	BB	2	5"x3 1/2"x3 3/8"	5"x3 1/2"x3 3/8"	5"x3 1/2"x3 3/8"	5"x3 1/2"x3 3/8"
Bolts for brace rod angles.....	CC	8	1/16" less than dia. of hole	1/16" less than dia. of hole	1/16" less than dia. of hole	1/16" less than dia. of hole
Bolts for alternate fastenings.....	DD	12	3/4" dia.	3/4" dia.	3/4" dia.	3/4" dia.
Bolts for top tie clamps.....	EE	4	5/8" dia., with washers	5/8" dia., with washers	5/8" dia., with washers	5/8" dia., with washers
Vertical tie rod angles.....	FF	4	3 1/2"x3 1/2"x3 3/8"	3 1/2"x3 1/2"x3 3/8"	3 1/2"x3 1/2"x3 3/8"	3 1/2"x3 1/2"x3 3/8"
Bolts securing vertical tie rod angles...	GG	8	3/4" dia.	3/4" dia.	3/4" dia.	3/4" dia.

*May be made of two pieces, securely bolted together.

Items "S", must be neatly fitted and driven into plates.

Items "AA", may be attached to girders between bolsters, or to both overhanging ends of girders.

Items "B", made of one piece shall have one 3/4 in. transverse bolt on either side of center pin to prevent splitting. When made of 2 or 3 pieces they shall have at least six 3/4 in. transverse bolts.

Items "L", shall have one 5/8 in. transverse bolt on either side of center pin to prevent splitting.

For length of slotted center pin hole see Fig. 5.

Girders over 8 ft. deep, weighing less than 20,000 lbs. per bolster, shall have bolsters as specified for girders weighing over 20,000 lbs. to 40,000 lbs., per bolster.

Girders more than 50 ft. long, if necessary to pass a curve of more than 20 degrees, nuts on one bolster should be loosened to allow girder to shift on bolster. After curve is passed all nuts must be tightened.

Items "R", must be sufficiently long to rest on center sill cover plate.

All wooden items must be hardwood.

See General Rules 4, 5, 6, 7, 9, 12 and 15 for further details.

GIRDERS, HORIZONTALLY, ON PIVOTED BOLSTERS—TWO OR MORE FLAT OR GONDOLA CARS

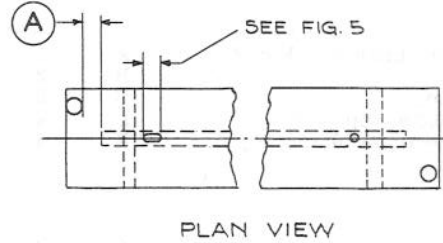
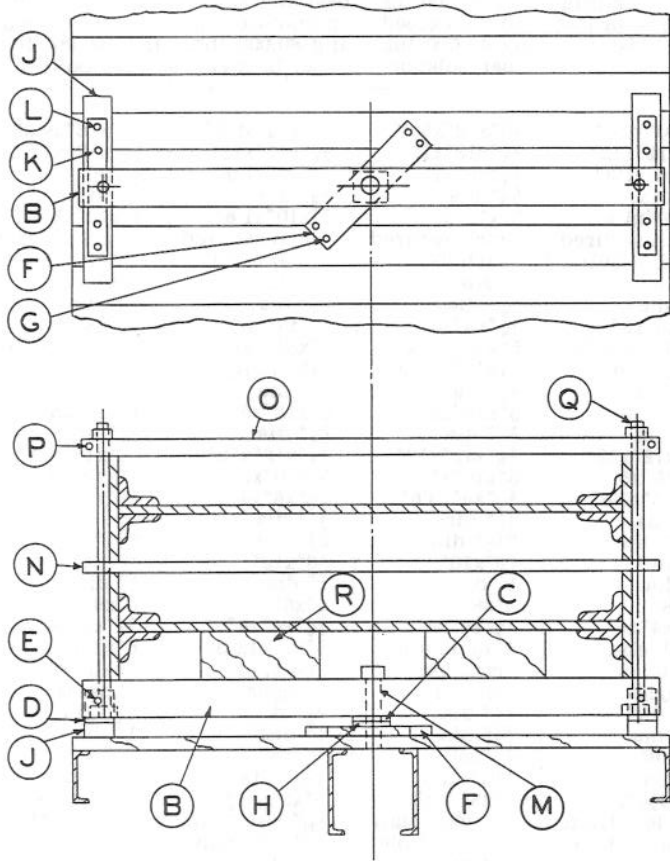

PLAN VIEW

Description	Item	No. of Pcs.	Loads weighing 15,000 lbs. or less per bolster	Loads weighing over 15,000 lbs. to 36,000 lbs. per bolster	Loads weighing over 36,000 lbs. per bolster
Brake wheel clearance. See Fig. 2.....	A				
Bolster.....	B	2	8"x10"x9'6"	10"x14"x9'6"	12"x14"x9'6"
Center-plate, top.....	C	2	3/8"x12"x12"	3/8"x12"x12"	3/8"x12"x12"
Side-bearing plate, top (bent).....	D	4	1/4"x6"x1'3"	1/4"x6"x1'7"	1/4"x6"x1'7"
Bolts for side-bearing plate, top.....	E	4	5/8" dia.	5/8" dia.	5/8" dia.
Center-plate backing.....	F	2	3"x12"x5'	3"x12"x5'	3"x12"x5'
Bolts for center-plate backing.....	G	8	3/4" dia.	3/4" dia.	3/4" dia.
Center-plate, bottom.....	H	2	3/8"x12"x12"	3/8"x12"x12"	3/8"x12"x12"
Side-bearing backing.....	J	4	3"x10"x5'	3"x10"x5'	3"x10"x5'
Side-bearing plate, bottom.....	K	4	1/4"x6"x3'6"	1/4"x6"x3'6"	1/4"x6"x3'6"
Bolts for side-bearing plate, bottom.....	L	16	3/4" dia.	3/4" dia.	3/4" dia.
Center-pin with head.....	M	2	2 1/2" dia.	2 1/2" dia.	2 1/2" dia.
Spacers.....	N	2	2"x8"	2"x8"	2"x8"
Top clamping-piece.....	O	2	4"x6"	6"x8"	6"x8"
Bolts for top clamping-piece.....	P	4	1/2" dia. with washers	1/2" dia. with washers	1/2" dia. with washers
Tie rods.....	Q	4	1 1/4" dia. with washers	1 1/4" dia. with washers	1 1/4" dia. with washers
Web bearing blocks, located as near flanges as possible ..	R	4	To suit	To suit	To suit

Items "B" made of one piece shall have one 3/4 in. transverse bolt on either side of center pin to prevent splitting. When made of 2 or 3 pieces they must have at least six 3/4 in. transverse bolts.

Item "F" shall have one 5/8 in. transverse bolt on either side of center-pin to prevent splitting.

For length of slotted center pin hole see Fig. 5.

All wooden items must be hardwood.

Girders more than 50 ft. long, if necessary to pass a curve of more than 20 degrees curvature, nuts on one bolster should be loosened to allow girder to shift on bolster. After curve is passed all nuts must be tightened.

Items "M" must be sufficiently long to rest on center sill cover plate.

See General Rules 4, 5, 6, 7, 9, 12, 15, 18 and 21 for further details.

THIS PAGE WAS LEFT BLANK INTENTIONALLY

Sec. 2—Fig. 60

TURNTABLES, RIGHT SIDE UP OR UPSIDE DOWN, PIVOTED BOLSTERS—TWO OR MORE FLAT CARS

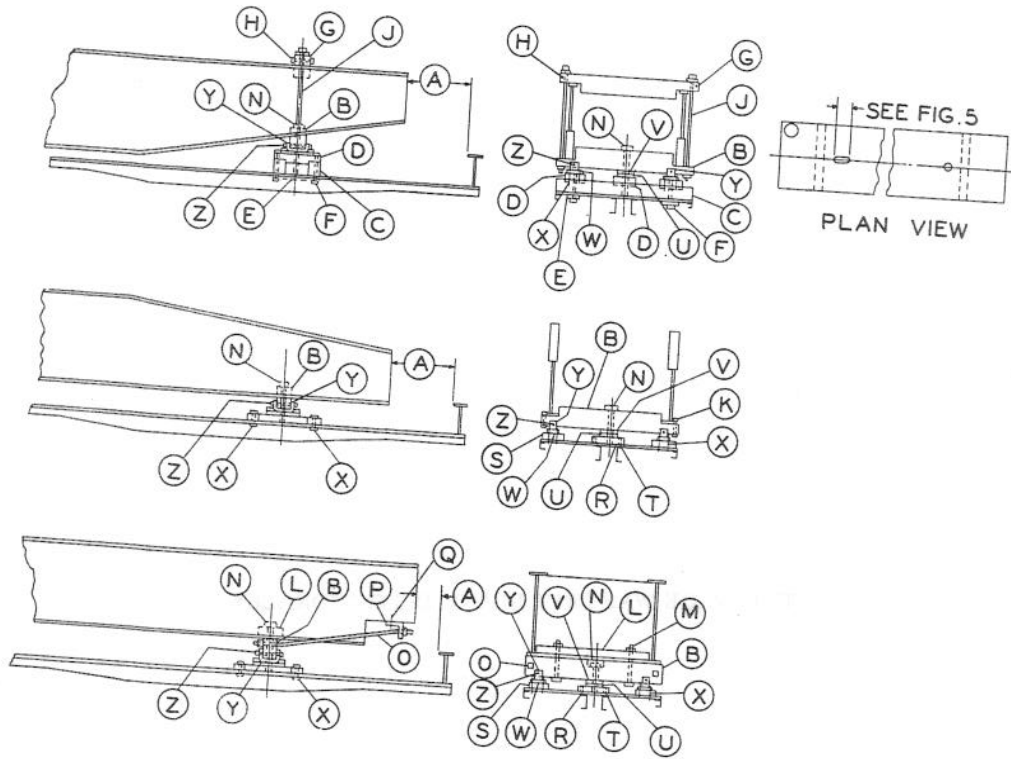

Sec. 2—Fig. 60

TURNABLES, RIGHT SIDE UP OR UPSIDE DOWN, PIVOTED BOLSTERS—TWO OR MORE FLAT CARS

Description	Item	No. of Pcs.	Loads weighing 15,000 lbs. or less per bolster	Loads weighing over 15,000 lbs. but not exceeding 36,000 lbs. per bolster	Loads weighing over 36,000 lbs. but not exceeding 57,500 lbs. per bolster	Loads weighing over 57,500 lbs. but not exceeding 100,000 lbs. per bolster
Brake wheel clearance. See Fig. 2	A					
Bolster	B	2	8"x10"x9'6"	10"x14"x9'6"	12"x16"x9'6"	14"x20" or 12"x22"x9'6"
Lower cribbing timber	C	4	10"x10"x9'6"	10"x10"x9'6"	10"x10"x9'6"	10"x10"x9'6"
Top cribbing timber (notched)	D	6	10"x10", length to suit	10"x10", length to suit	10"x10", length to suit	10"x10", length to suit
Cleats	E	4	2"x6"x3'2"	2"x6"x3'2"	2"x6"x3'2"	2"x6"x3'2"
Bolts or cribbing timbers	F	8	7/8" dia. length to suit	7/8" dia. length to suit	7/8" dia. length to suit	7/8" dia. length to suit
Top Tie Clamp	G	2	8"x10" length to suit	8"x10" length to suit	8"x10" length to suit	8"x10" length to suit
Bolts for tie clamp (with washers)	H	4	1/2" dia.	1/2" dia.	1/2" dia.	1/2" dia.
Tie rods, with washers	J	4	1 1/4" dia. length to suit	1 1/4" dia. length to suit	1 1/4" dia. length to suit	1 1/4" dia. length to suit
Bolts for bolsters, with washers	K	8	3/4" dia.	3/4" dia.	3/4" dia.	3/4" dia.
Bolster clamping timber	L	2	6"x12" length to suit. Use one bolt 1/2" dia., cross-wise, with washers, at each end to prevent splitting.	6"x12" length to suit. Use one bolt, 1/2" dia., cross-wise, with washers, at each end to prevent splitting.	6"x12" length to suit. Use one bolt 1/2" dia., cross-wise, with washers, at each end to prevent splitting.	6"x12" length to suit. Use one bolt, 1/2" dia., cross-wise, with washers, at each end to prevent splitting.
Bolts for clamping timber, with washers	M	4	1 1/8" dia.	1 1/8" dia.	1 1/8" dia.	1 1/8" dia.
Center-pin with head	N	2	2 1/2" dia.	2 1/2" dia.	2 1/2" dia.	2 1/2" dia.
Brace rods (with washers)	O	4	1 1/4" dia.	1 1/4" dia.	1 1/4" dia.	1 1/4" dia.
Brace rod angles	P	4	4"x4"x3/8"	4"x4"x3/8"	4"x4"x3/8"	4"x4"x3/8"
Bolts for brace rod angles	Q	8	3/4" dia.	3/4" dia.	3/4" dia.	3/4" dia.
Center-plate backing	R	2	3"x12"x5'	3"x12"x5'	3"x12"x5'	4"x12"x5'
Side-bearing backing	S	4	3"x10"x5'	3"x10"x5'	3"x10"x5'	4"x10"x5'
Bolts for center-plate backing	T	8	3/4" dia.	3/4" dia.	3/4" dia.	3/4" dia.
Center-plate, bottom	U	2	3/8"x12"x12"	3/8"x12"x12"	3/8"x12"x12"	1/2"x12"x12"
Center-plate, top	V	2	3/8"x12"x12"	3/8"x12"x12"	3/8"x12"x12"	3/8"x12"x12"
Side-bearing plate, bottom	W	4	3/8"x6"x3'6"	3/8"x6"x3'6"	3/8"x6"x4'	3/8"x6"x4'
Bolts for side-bearing plate, bottom, with washers	X	8	3/4" dia.	3/4" dia.	3/4" dia.	3/4" dia.
Side-bearing plate, top, (bent)	Y	4	1/4"x6"x1'3"	1/4"x6"x1'7"	1/4"x6"x1'9"	3/8"x6"x2'1"
Bolts for side-bearing plate, top	Z	4	5/8" dia.	5/8" dia.	5/8" dia.	5/8" dia.

When height of cribbing is sufficient, by use of 1 transverse and 1 lengthwise course of timbers (Items "C" and "D"), Items "C" must be spaced 18 in. apart and when height requires more than 2 courses, the spacing must be proportionately increased.

Bolsters may be secured to turntables by Items "G" and "J", "K" or Items "L" and "M".

All wooden items must be hardwood.

For length of slotted center pin hole see Fig. 5.

Turntables more than 50 ft. long, if necessary to pass a curve of more than 20 degrees curvature, nuts on one bolster should be loosened to allow turntable to shift on bolster. After curve is passed, all nuts must be tightened.

See General Rules 4, 5, 6, 7, 9, 12, 15, 18 and 21 for further details.

Sec. 2—Fig. 61

BOX TYPE GIRDERS ON PIVOTED STEEL BOLSTERS—TWO OR MORE FLAT CARS

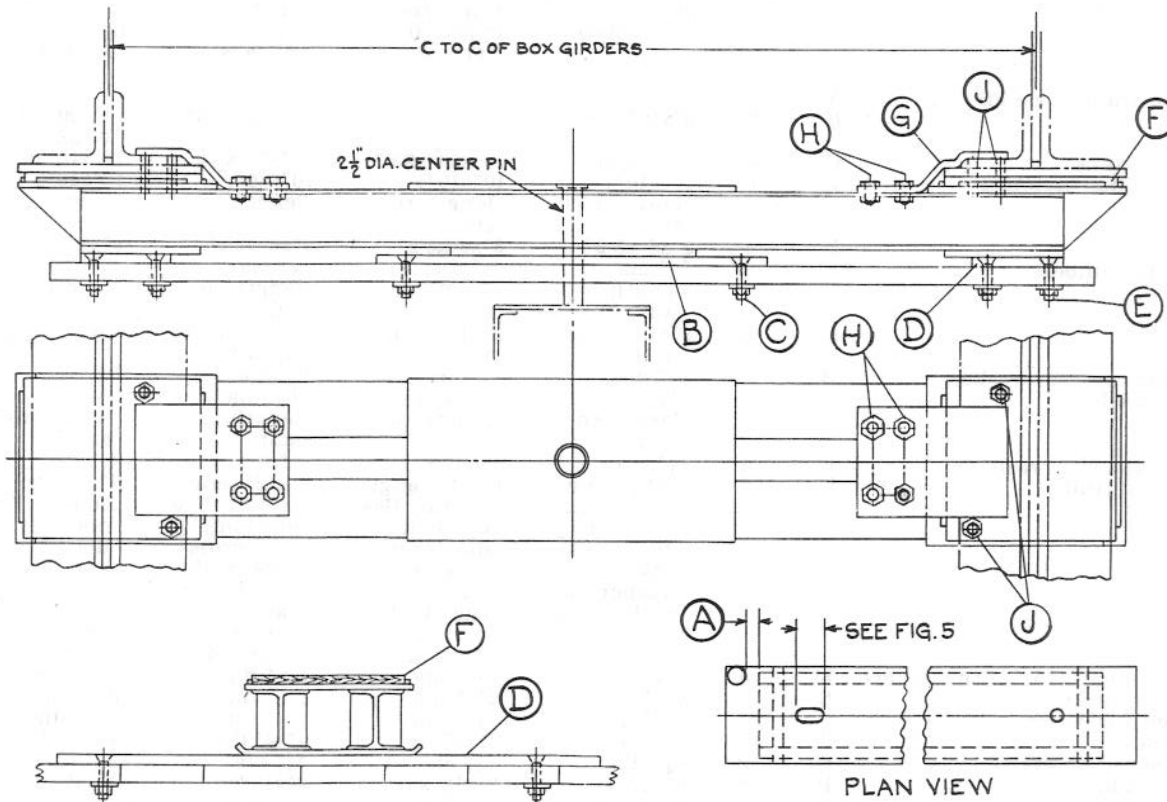

Item	No. of Pcs.	Description
A		Brake wheel clearance. See Fig. 2.
B	2 ea. bolster	$\frac{1}{2}$ in. x 12 in. x 5 ft. steel center-plate bearings.
C	2 ea. Item "B"	$\frac{3}{4}$ in. dia. bolts, length to suit, with $\frac{1}{2}$ in. x 4 in. x 4 in. plates under floor.
D	2 ea. bolster	$\frac{3}{8}$ in. x 6 in. x 4 ft. steel side-bearing plates, bottom.
E	4 ea. Item "D"	$\frac{3}{4}$ in. dia. bolts, length to suit, with $\frac{1}{2}$ in. x 4 in. x 18 in. plates under floor.
F	2 ea. bolster	1 in. thick, hardwood, width and length to suit bolsters.
G	2 ea. bolster	$\frac{3}{4}$ in. x 12 in. steel clamping plates, length and formed to suit. Substitute, if desired, built-up clamping plates consisting of suitable thicknesses of steel plates. Edges of filler pieces must contact flanges of girders.
H	4 ea. Item "G"	1 in. dia. bolts, length to suit, with two hexagon nuts on each bolt, passed through Items "G" and flange of bolsters.
J	4 ea. bolster	1 in. dia. bolts, length to suit, with two hexagon nuts on each bolt. Pass through blank rivet holes in girder flanges, Items "F" and bolsters.

Built-up steel bolsters must be of sufficient size and strength to carry load.

Center pin must be $2\frac{1}{2}$ in. dia., with head and long enough to rest on center sill cover plate.

When necessary to provide clearance, heads of bolts, Items "C" and "E" must be countersunk in plates, Items "B" and "D".

After girder rivet heads have settled into Items "F", all Items "J" and "H" must be again tightened before threads are checked.

See General Rules 5, 6, 8, 9, 15, 18 and 21 for further details.

Sec. 2—Fig. 62

WIRE ROPE, CABLE, AND SIMILAR COMMODITIES ON REELS—GONDOLA CARS

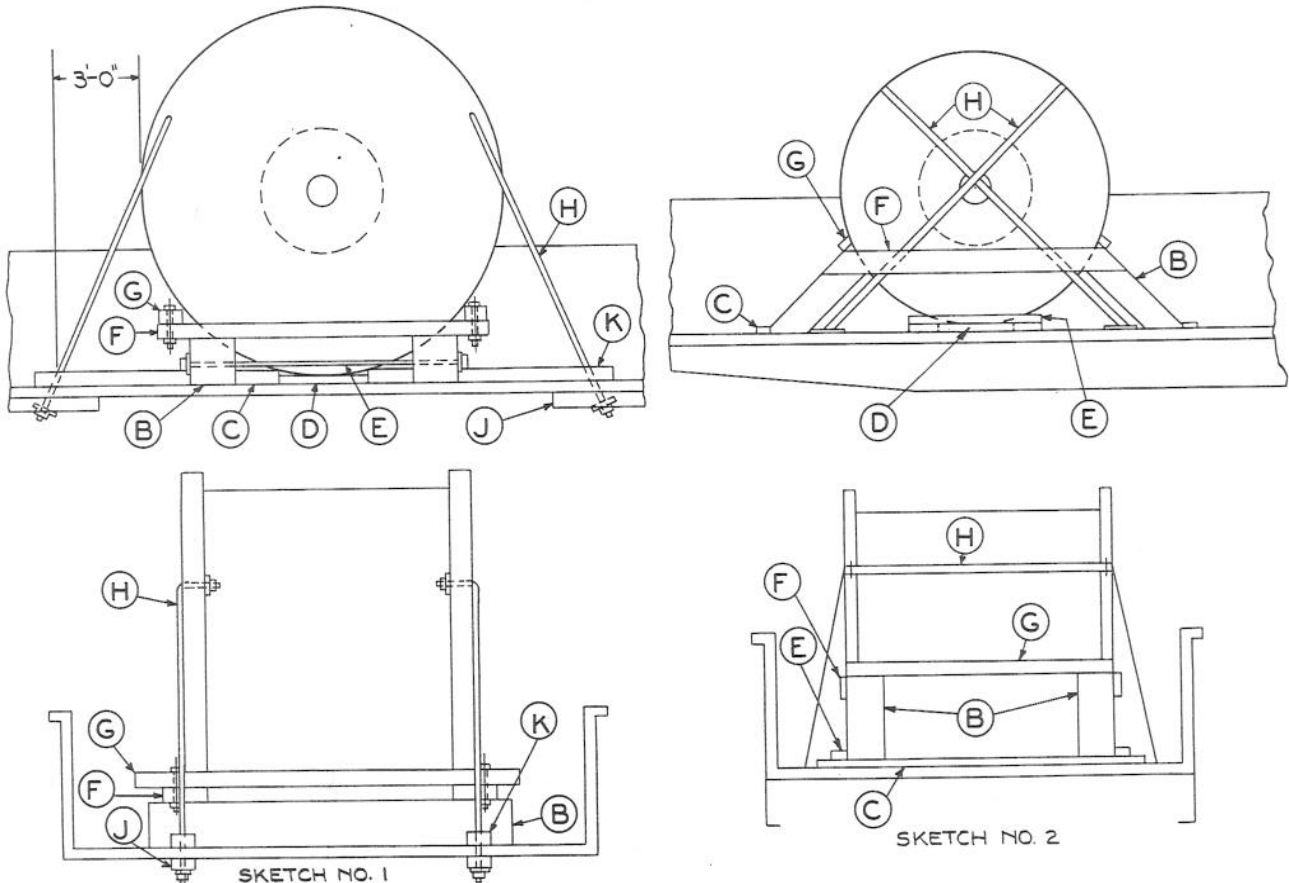

Item	No. of Pcs.	Description
A		Brake wheel clearance. See Fig. 2.
B	2 ea. reel, Sketch 1 4 ea. reel, Sketch 2	12 in. x 12 in., hardwood, long enough to extend 8 in. beyond each side of reel, cut to fit contour of reel heads, for reels 4 ft. 8 in. and over in diameter, weighing 5,000 lbs. and over. 6 in. x 8 in., hardwood. Place at about a 45 degree angle to floor, the top edge to be about $\frac{3}{5}$ the distance from floor to center of reel. Secure each to floor with six 40-D nails. 6 in. x 6 in. hardwood, may be used on reels less than 4 ft. 8 in. in diameter, weighing less than 5,000 lbs.
C	2 ea. reel, Sketch 1 2 ea. reel, Sketch 2	4 in. x 12 in., hardwood, length same as Item "B", cut to fit contour of reel heads. Locate against Item "B" and secure to floor with two 60-D nails.
D	2 ea. reel, Sketches 1 and 2	2 in. x 8 in., hardwood, length equal to distance between Items "C" per Sketch 1, and 3 ft. per Sketch 2. Not required for reels weighing less than 3,500 lbs.
E	2 ea. reel, Sketch 1 4 ea. reel, Sketch 2	$\frac{5}{8}$ in. diameter, with $\frac{3}{16}$ in. x $2\frac{1}{2}$ in. x $2\frac{1}{2}$ in. washers. Locate outside of and against faces of reel heads. 2 in. x 4 in., hardwood, length equal to width of reel. Locate against Item "B" and nail each to floor with eight 20-D nails.
F	2 ea. reel, Sketch 1 2 ea. reel, Sketch 2	2 in. x 6 in., hardwood, long enough to extend to outside edges of Items "B". Locate against side of reel head and nail to Items "B" with five 30-D nails at each end.
G	2 ea. reel, Sketch 1 2 ea. reel, Sketch 2	4 in. x 6 in., hardwood, length same as Item "B". Locate on top of Items "F" and against reel head. Secure to Items "F" with one $\frac{5}{8}$ in. dia. bolt, with washers, each end.
H	4 ea. reel, Sketches 1 and 2	2 in. x 4 in., hardwood, length equal to width of reel. Bevel edge to fit contour of reel heads. Locate on top of Items "B" and against edges of reel heads, and secure with three 30-D nails each end. $\frac{3}{4}$ in. dia., bolted through reel heads about $\frac{3}{5}$ dia. of reel from floor and through Items "K", floor, and Items "J", 3 ft. from reel, as shown on Sketch 1. Not required for reels less than 4 ft. 8 in. in dia. weighing less than 5,000 lbs. Substitute, if desired, 2 in. x .050 in. high tension bands, applied as shown on Sketch 2, secured to floor with standard anchor plates and to edges of reel heads with staples.
J	1 ea. Item "H", Sketches 1 and 2	4 in. x 4 in. x 18 in., hardwood, or $\frac{1}{2}$ in. x 4 in. x 18 in. plate under floor. Not required when bands, Items "H" are used.
K	2 ea. Item "B", Sketch 1	4 in. x 6 in., hardwood, length to suit, located as shown and secured with three 60-D nails.

Reels weighing 3,500 lbs. and less may be loaded one, two or three in a row across the car in a like manner to Sketches 1 and 2. All vacant space between the reels must be filled in with blocking, secured to prevent the reels from moving. See General Rules 4, 5, 9, 14 and 15 for further details.

Sec. 2—Fig. 63

WIRE ROPE, CABLE AND SIMILAR COMMODITIES ON REELS, LENGTHWISE—FLAT CARS

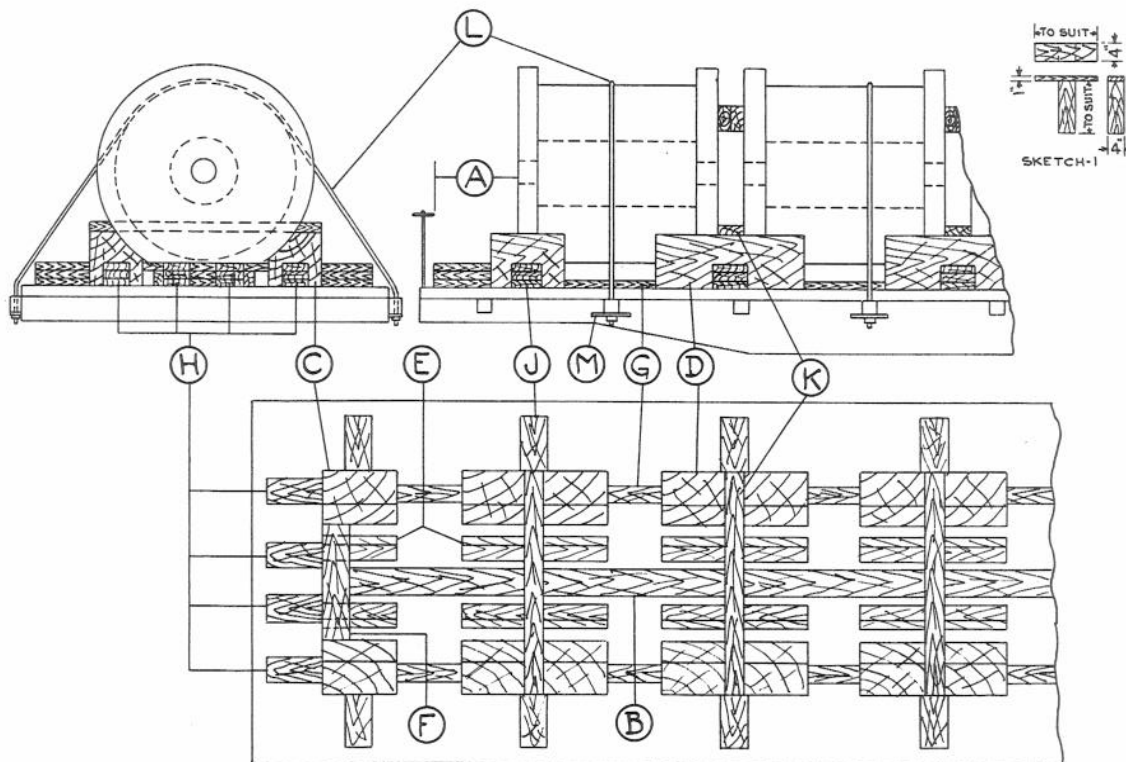

Item	No. of Pcs.	Description
A		Brake wheel clearance. See Fig. 2.
B	1	2 in. x 6 in., hardwood, length equal to distance between Items "F". Locate at center of car and nail to floor with 20-D nails spaced about 3 ft. apart.
C	1 reel only, 4. For more than 1 reel, 2 each end of load.	12 in. x 12 in. x 16 in., hardwood, for reels 4 ft. and over in diameter. 8 in. x 8 in. x 16 in., hardwood, for reels less than 4 ft. in diameter. Bevel top inside edge about 4 in. to fit contour of reel heads.
D	As required.	12 in. x 12 in. x 30 in., hardwood, for reels 4 ft. and over in diameter. 8 in. x 8 in. x 30 in., hardwood, for reels less than 4 ft. in diameter. Bevel top inside edge about 4 in. to fit contour of reel heads.
E	1 ea. Items "C" and "D"	4 in. x 6 in., hardwood, length to suit. Bevel top inside edge about 4 in. to fit contour of reel heads. Locate between Items "B" and "C", or "D", and toe-nail each to floor with four 20-D nails.
F	1 ea. end of load	Each shall consist of 3 pcs., 2 in. x 6 in., hardwood. Two lower pieces must contact Items "E" and top piece must contact Items "C". Nail each bottom piece to floor against Item "B" with eight 20-D nails and each of the other two to the one below with six 20-D nails each.
G	As required	2 in. x 4 in., hardwood, length equal to distance between Items "C" and "D" and Items "D". Nail each to floor with four 20-D nails.
H	4 ea. end of load	Each shall consist of 3 pcs., 2 in. x 6 in. x 12 in. hardwood. Locate the 2 outside items against Items "C". Locate bottom and center intermediate pieces against Items "E" and "F", and top intermediate pieces against Items "F". Nail each bottom piece to floor with eight 20-D nails, and each of the other two pieces to the one below with six 20-D nails.
J	1 ea. Items "C" and "D"	Each shall consist of 2 pcs. of 2 in. x 6 in. x 12 in., hardwood. Locate against Items "C" and "D" and secure bottom piece to floor with eight 20-D nails and the top piece to the one below with six 20-D nails.
K	As required	2 in. x 4 in., hardwood, long enough to extend to outside edges of Items "D". Nail each end to Items "D" with four 20-D nails.
L	1 ea. reel	Reels weighing 25,000 lbs. or less, $\frac{3}{8}$ in. diameter rod. For reels over 25,000 lbs., $\frac{3}{4}$ in. diameter rod. Locate over top of reel with ends through stake pockets and Item "M". Substitute, if desired, for $\frac{3}{8}$ in. rod, one 2 in. x .050 in. high tension band attached to stake pocket, and for the $\frac{3}{4}$ in. rod, two 2 in. x .050 in. high tension bands attached to stake pocket.
M	2 ea. Item "L"	$\frac{1}{2}$ in. x 4 in x 10 in. plate. Not required when high tension bands are used.

Vacant space between reels at top must be completely filled in by the use of suitable fillers securely nailed to the outer face of adjoining reels or as shown in Sketch 1.

See General Rules 4, 5, 9, 14 and 15 for further details.

Sec. 2—Fig. 64

LARGE CABLE REELS, SINGLE OR DOUBLE ROW, CROSSWISE—FLAT CARS

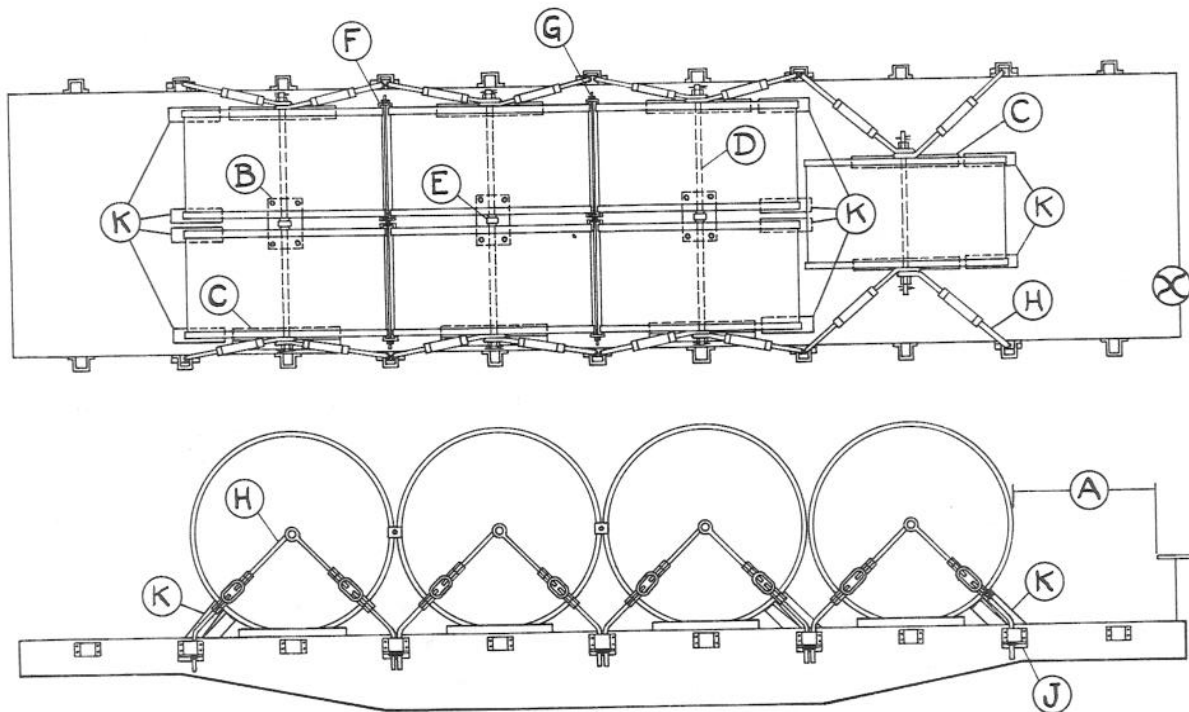

Item	No. of Pcs.	Description
A		Brake wheel clearance. See Fig. 2.
B	1 ea. two side by side reels	$\frac{1}{2}$ in. x 14 in. x 20 in. plate, secured to floor with four $\frac{1}{2}$ in. x 3 in. lag screws.
C	Single reel, 2; side by side reels, 1 ea. reel	4 in. x 4 in. x 3 ft. 9 in. angle. Secure each to floor with four $\frac{5}{16}$ in. x 3 in. spikes. When the two center spikes cannot be applied, use a 2 in. x 4 in. x 24 in. back-up cleat, nailed to floor with three 30-D nails.
D	1 ea. two side by side reels	$1\frac{3}{4}$ in. dia. rod, length to suit, with nut and cotter at each end.
E	1 ea. side by side reel	$3\frac{1}{2}$ in. extra heavy pipe spacer, length to suit, with ends turned to fit inside of reel core.
F	2 ea. two adjoining reels	$\frac{5}{8}$ in. x 4 in. rim clamp, formed to suit.
G	1 ea. two adjoining reels.	1 in. dia. clamp bolt, length to suit, with nut and lock washer.
H	4 ea. single reel; 4 ea. two side by side reels	$1\frac{1}{4}$ in. dia. rod, consisting of eye bolt top section with 2 in. dia. welded eye, bent to suit, $1\frac{1}{4}$ in. turnbuckle with jam nut on each rod. Bottom section formed to pass through stake pocket and Items "J".
J	To suit	$\frac{3}{8}$ in. x 2 in. x 3 in. x 11 in. angle with two $1\frac{1}{16}$ in. dia. holes spaced $2\frac{1}{2}$ in. centers drilled in 3 in. leg of angle.
K	To suit	Hardwood block consisting of one piece of 6 in. x 6 in. x 14 in. cut square on one end, with $5\frac{1}{2}$ in. bevel on opposite end, and one piece 6 in. x 6 in. x $19\frac{1}{2}$ in. with one end beveled 1 in. and opposite end beveled $4\frac{1}{2}$ in. Nail both blocks to the floor, one above the other, with four 40-D nails in each.

The width of side by side reels must not exceed 20 in. less than width of car to provide necessary angularity of Items "H".

Suitable metal blocking may be substituted for Items "K".

See General Rules 4, 5, 9, 14 and 15 for further details.

LARGE SINGLE CABLE REEL—LENGTHWISE—FLAT CARS

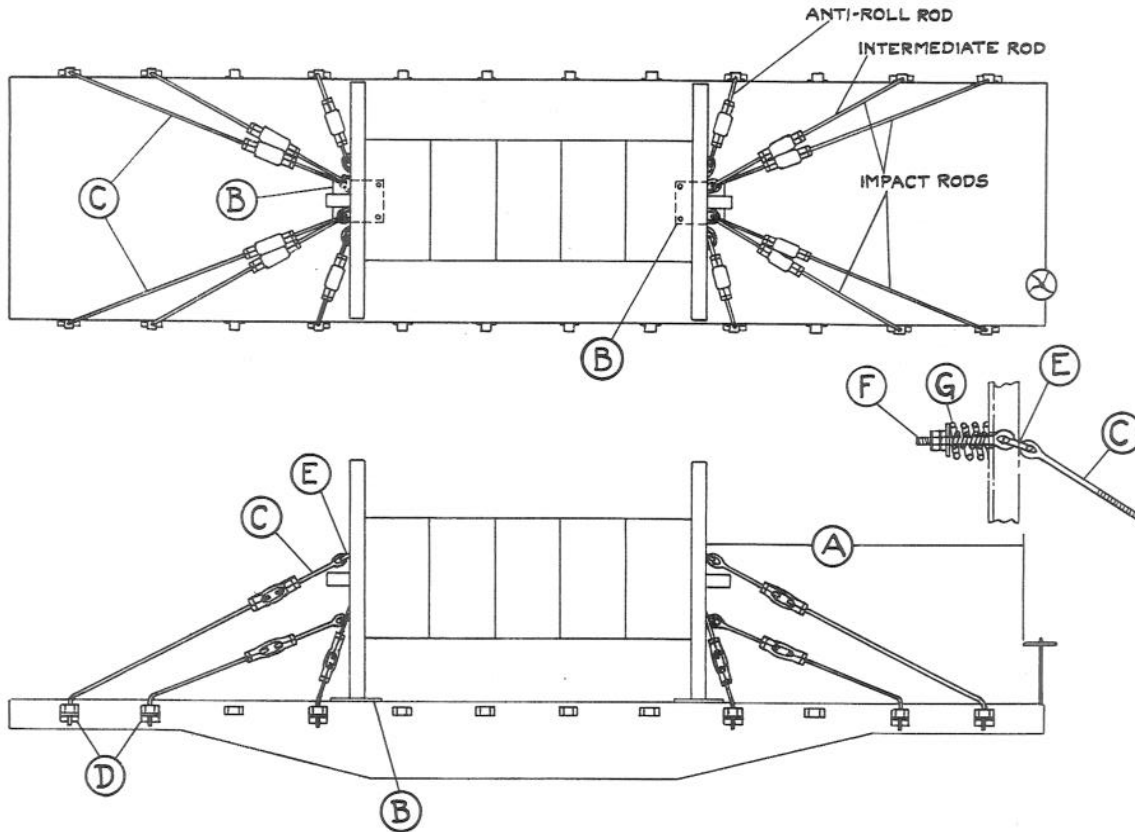

Item	No. of Pcs.	Description
A		Brake wheel clearance. See Fig. 2.
B	2	Steel plate $\frac{1}{2}$ in. x 14 in. x 20 in. for reels weighing 25,000 lbs. or less; $\frac{3}{4}$ in. x 14 in. x 20 in. for reels weighing over 25,000 lbs. Secure $\frac{1}{2}$ in. plates to floor with four $\frac{1}{2}$ in. x 3 in. lag screws and $\frac{3}{4}$ in. plates with four $\frac{3}{4}$ in. x 3 in. lag screws.
C	Reel 25,000 lbs. or less 8; Reel over 25,000 lbs., 12	$1\frac{1}{4}$ in. dia. rod, length to suit, consisting of eye bolt top section with $1\frac{3}{4}$ in. dia. welded eye, $1\frac{1}{4}$ in. turnbuckle with jam nuts. Top section to be secured with Items "E", bottom section to pass through stake pocket and Item "D".
D	1 ea. Item "C"	$\frac{3}{8}$ in. x 2 in. x 3 in. x 11 in. angle with one $1\frac{5}{16}$ in. dia. hole drilled in 3 in. leg of angle.
E	1 ea. Item "C"	$1\frac{1}{4}$ in. dia. link with $1\frac{1}{2}$ in. x $3\frac{1}{4}$ in. opening.
F	1 ea. Item "C"	$1\frac{1}{2}$ in. dia. eye bolt, 20 in. long, with $2\frac{1}{4}$ in. dia. welded eye with 8 in. threaded end. Use $\frac{1}{4}$ in. spring plate.
G	1 ea. Item "C"	8 in. double coil compression spring.

When reel exceeds 25,000 lbs., six rods shall be used on each end of reel as shown. For reel of 25,000 lbs. or less only four rods need be used, omitting the two impact rods marked "intermediate" at each end.

Items "E", "F" and "G" are a component part of reel.

See General Rules 4, 5 and 15 for further details.

WIRE ROPE, CABLE AND SIMILAR COMMODITIES ON REELS—LENGTHWISE—FLAT CARS

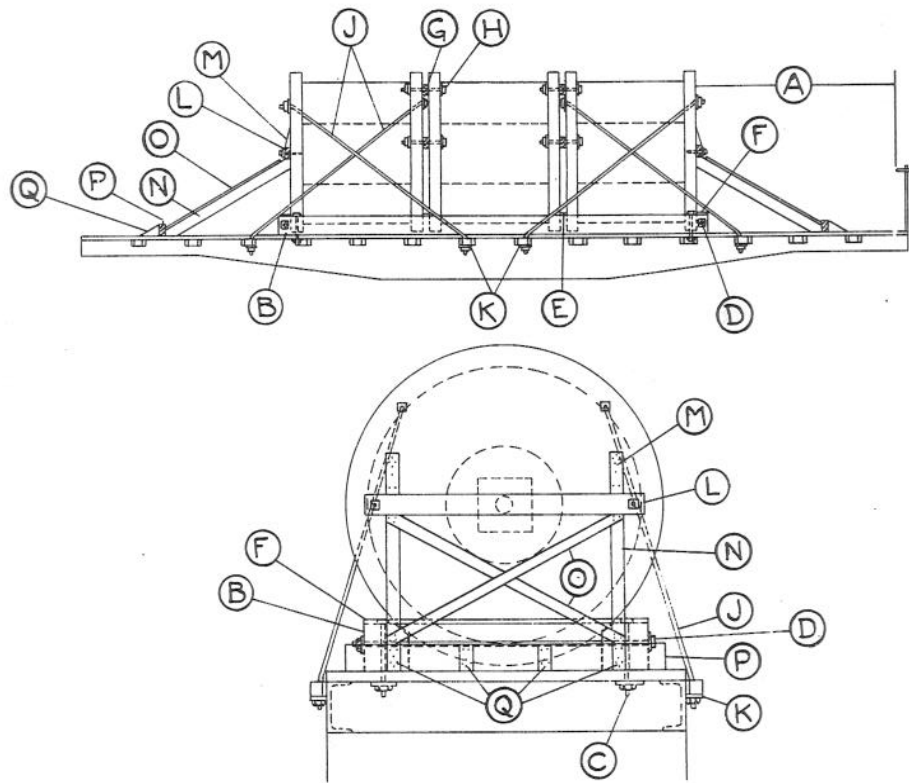

Item	No. of Pcs.	Description
A		Brake wheel clearance. See Fig. 2.
B	2	12 in. x 12 in., hardwood, lengthwise of car, extending 8 in. beyond each end of load. Bevel top inside edge about 4 in. to fit contour of reel head. Locate so as to provide about 1 in. clearance above floor.
C	2 ea. Item "B"	3/4 in. dia. bolts, with washers. Use a 4 in. x 4 in. x 18 in. hardwood cleat, or a 1/2 in. x 4 in. x 18 in. plate under floor.
D	2 ea. Item "B"	3/4 in. dia. tie rods, with nuts and washers, length to suit.
E	1 between ea. two adjacent reels	2 in. x 4 in. hardwood, length to suit. Nail to Items "B" with two 20-D nails in each end.
F	2	2 in. x 8 in. hardwood, length to suit. Nail to Items "B" with four 20-D nails in each end.
G	2 between ea. two adjacent reels	4 in. x 4 in. hardwood, length to suit. Locate one at center and one near top of each two reels, secured with Items "H".
H	2 ea. Item "G"	3/4 in. dia. bolts, with nuts and washers, length to suit.
J	4 ea. single or end reels	3/4 in. dia. rods, with nuts and washers, length to suit. Top end to extend through washer and reel head, bottom end to extend through stake pockets and Item "K", as shown.
K	1 ea. Item "J"	1/2 in. x 4 in. x 10 in. plate.
L	2	4 in. x 6 in. hardwood, length about 4 in. less than dia. of reel head. Secure to reel head with two 3/4 in. x 8 in. lag screws.
M	4	4 in. x 6 in. x 12 in. hardwood wedge blocks. Secure each to reel head above Items "L" with four 20-D nails.
N	4	4 in. x 6 in. hardwood, length and ends cut to suit. Secure to reel head and car floor with three 60-D nails in each end.
O	4	1 1/4 in. x 3 in. hardwood, length to suit. Nail to Items "N" with two 20-D nails at each end.
P	2	4 in. x 6 in. x 72 in. hardwood. Nail each to floor with eight 60-D nails.
Q	8	4 in. x 6 in. x 12 in. hardwood wedge blocks. Nail each to floor with four 20-D nails.

If desired, when shipments consist of two reels, they may be loaded and secured separately at each end of car. See General Rules 4, 5, 9, 14 and 15 for further details.

Sec. 2—Fig. 67

WIRE ROPE, CABLE AND SIMILAR COMMODITES ON REELS—LENGTHWISE—GONDOLA CARS

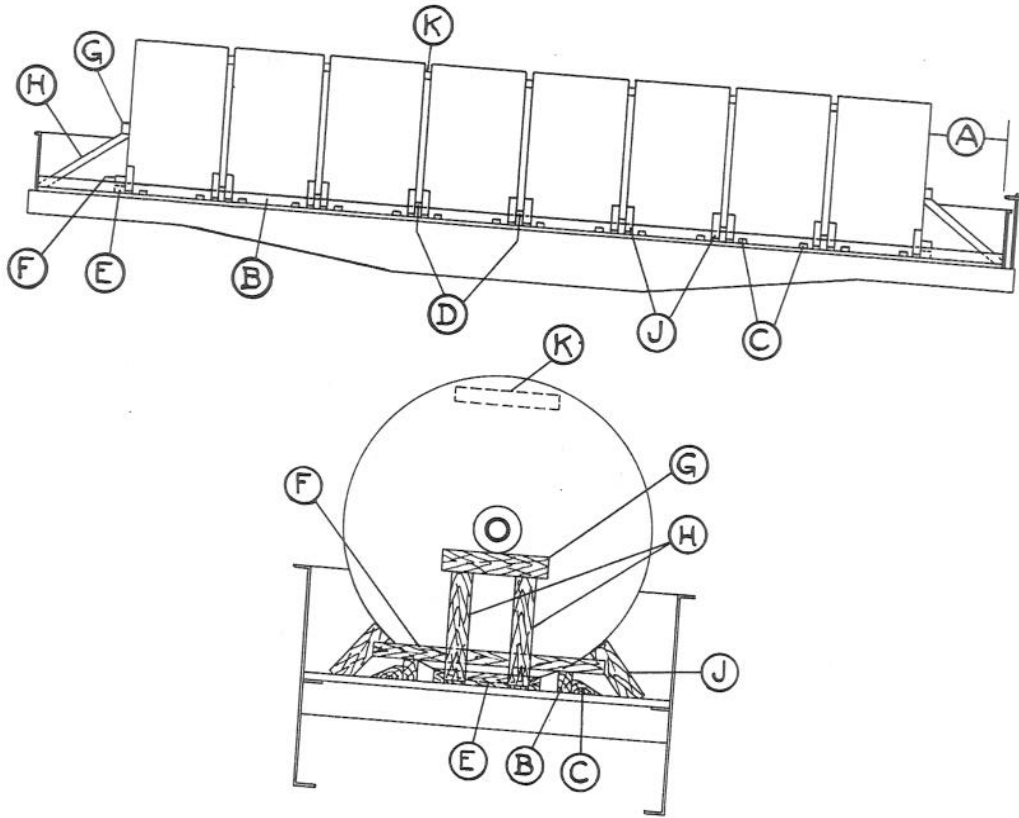

Item	No. of Pcs.	Description
A		Brake wheel clearance. See Fig. 2.
B	2	4 in. x 6 in. hardwood, full length of car. Bevel inside edge about 1 in. to fit contour of reel head. Locate so as to provide about 1 in. clearance above floor. May be made of two pieces spliced together.
C	4 per reel	4 in. x 6 in. x 12 in. hardwood wedge blocks. Locate against Items "B" and nail each to floor with three 60-D nails.
D	1 between ea. two adjacent reels	2 in. x 4 in. hardwood, length to suit. Nail to Items "B" with two 20-D nails in each end.
E	2	4 in. x 6 in. x 30 in., hardwood. Locate one against each end of load and nail to floor with four 60-D nails.
F	2	2 in. x 6 in., hardwood, length to suit. Locate on top of and nail to Items "B" with three 30-D nails at each location.
G	2	4 in. x 6 in. x 30 in., hardwood. Secure one to end of reel head on each end of load with two 1/2 in. x 8 in. lag screws.
H	4	4 in. x 6 in., hardwood, length and ends cut to suit. Secure to reel head and car floor with three 60-D nails in each end.
J	4 per reel	4 in. x 6 in. x 19 in. hardwood, with beveled ends. Locate two each side of reel against reel ends and nail to floor with three 60-D nails in each.
K	1 between ea. two adjacent reels	4 in. x 4 in. x 30 in. hardwood. Secure to reel head with three 60-D nails at each end.

See General Rules 4, 5, 9 and 14 for further details.

ELECTRIC CABLE AND SIMILAR COMMODITIES ON REELS—LENGTHWISE—FLAT CARS

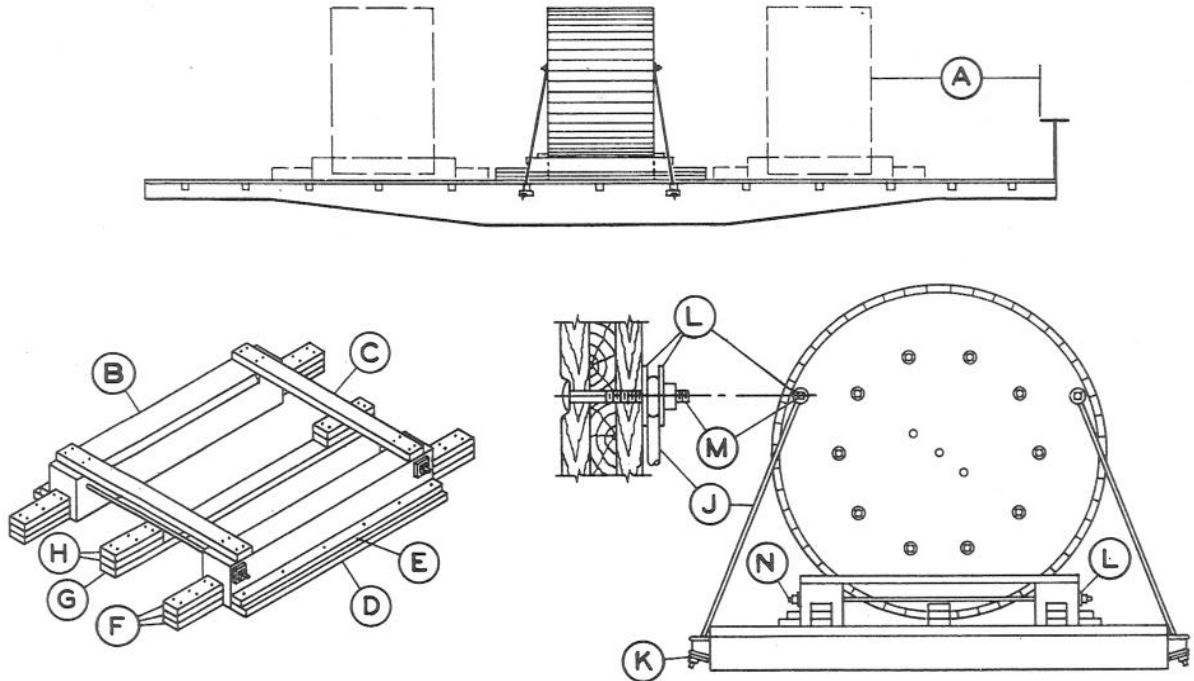

Item	No. of Pcs.	Description
A		Brake wheel clearance. See Fig. 2.
B	2 ea. reel	10 in. x 10 in. for reels with head diameter 78 in. or less; 12 in. x 12 in. for reels with head diameter over 78 in., long enough to extend 10 in. beyond each side of reel head. Bevel inside corner 4 in. deep, 1 in. longer than width of reel.
C	2 ea. reel	2 in. x 6 in., long enough to extend to outside edges of Items "B". Secure each to Items "B" with four 20-D nails at each location.
D	2 ea. reel	2 in. x 6 in., length equal to Items "B". Locate against Items "B" and nail to floor with 20-D nails spaced about 12 in. apart.
E	2 ea. reel	2 in. x 4 in., length equal to Items "B". Locate against Items "B", on top of Items "D" and nail to Items "D" with 20-D nails spaced about 12 in. apart.
F	4 ea. reel	Each to consist of three pieces of 2 in. x 6 in. x 18 in. Locate against Items "B". Nail lower piece to floor with six 20-D nails and top pieces to those below with six 20-D nails.
G	1 ea. reel	2 in. x 6 in., long enough to extend 18 in. beyond each side of reel head. Locate as shown and nail to floor with six 20-D nails at each end. Not required for reel heads having head diameter 78 in. or less.
H	2 ea. reel	Each to consist of two pieces of 2 in. x 6 in. x 18 in. Locate against reel head on top of Item "G". Nail lower piece to Item "G" with six 20-D nails and top piece to the one below with six 20-D nails. Bottom piece to be nailed to floor when Item "G" is not used.
J	4 ea. reel	$\frac{3}{4}$ in. dia. rods, length to suit, with welded eye on one end, threaded on opposite end. Secure top end to reel with Item "M" and pass opposite end through stake pocket and Item "K".
K	1 ea. Item "J"	$\frac{1}{2}$ in. x 4 in. x 10 in. plate.
L	12 ea. reel	$\frac{3}{16}$ in. x 4 in. washers. Place one between Item "J" and reel head, one between Item "J" and nut and two on Item "N".
M	4 ea. reel	$\frac{3}{4}$ in. x 8 in. bolt. Locate one-sixth the diameter of reel head above center of reel. Pass through Items "J", "L" and reel head and tighten so as to draw head into wood.
N	2 ea. reel	$\frac{3}{4}$ in. dia. rods, long enough to tie Items "B" together.

See General Rules 4, 5, 9, 14 and 15 for further details.

WIRE ROPE, CABLE AND SIMILAR COMMODITIES ON REELS—CROSSWISE—GONDOLA CARS

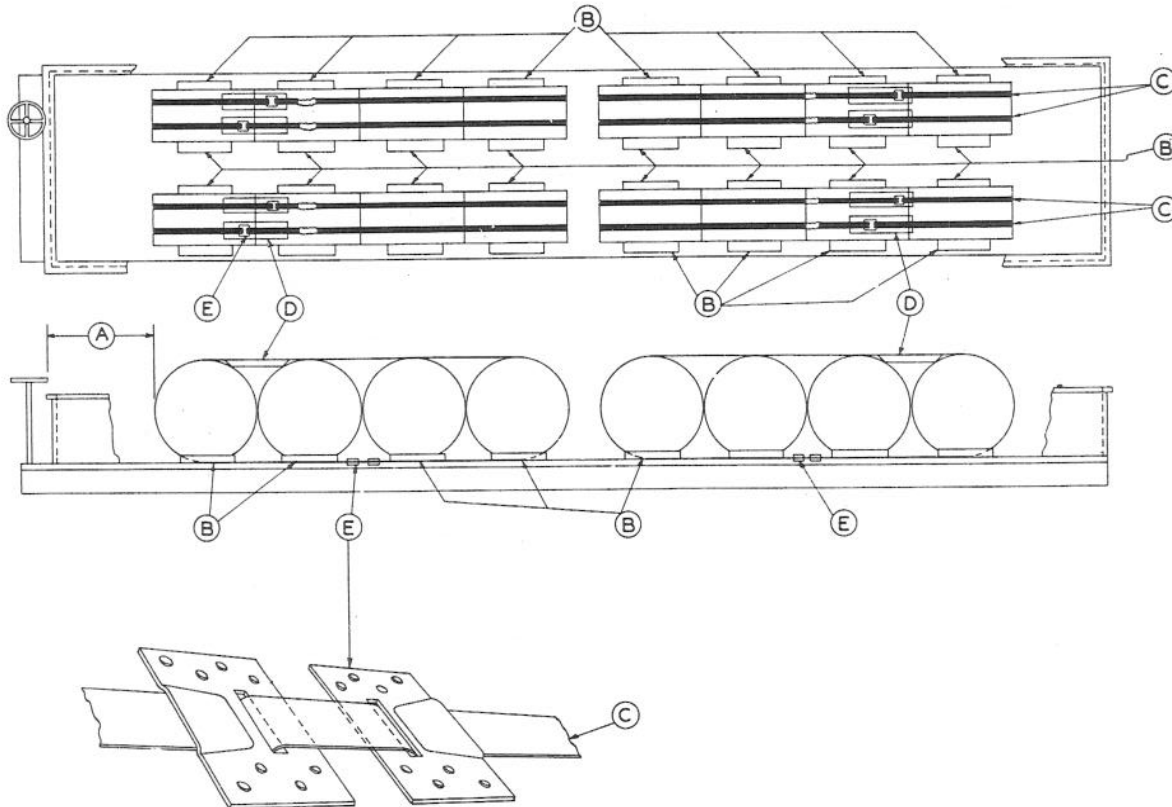

Item	No. of Pcs.	Description
A		Brake wheel clearance. See Fig. 2.
B	1 ea. reel	2 in. x 4 in. x 30 in., hardwood. Locate against outside of reel head and secure to floor with six 20-D nails.
C	2 ea. row unit	2 in. x .050 in. high tension bands, suitably spaced.
D	1 ea. band	2 in. x 6 in., hardwood, length to suit and beveled at ends. Secure to reels with three 20-D nails at each end.
E	3 ea. band	Mechanical brakeman, each secured with $\frac{1}{2}$ in. x $1\frac{1}{4}$ in. drive screws. Locate two on floor suitably spaced between reels and one on each Item "D".

When space between rows of reels will permit, additional Items "B" are required against inside of reel heads.

See General Rules 4, 5, 9, 14 and 15 for further details.

STEEL WIRE MESH OR BAR MATS EDGEWISE—GONDOLA CARS

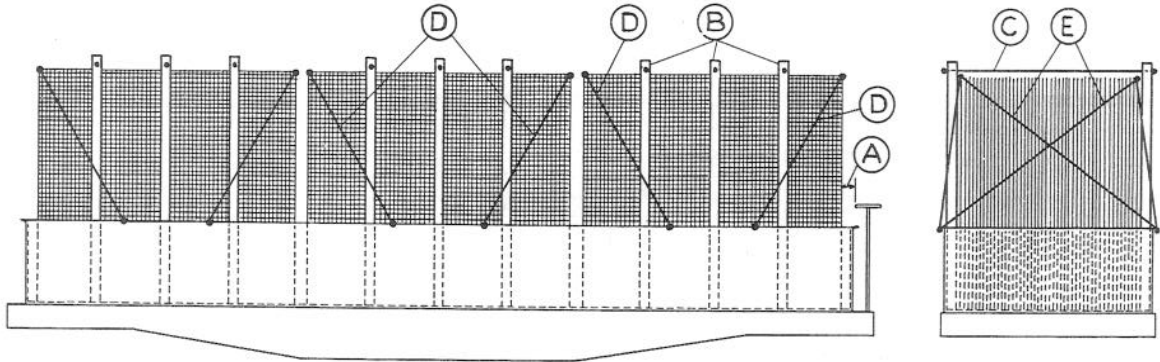

Item	No. of Pcs.	Description
A		Brake wheel clearance. See Fig. 2.
B	Pile 20 ft. long or less, 3 pr. Pile over 20 ft. long, 4 pr.	Stakes, hardwood, equally spaced, inside or outside. Not required for loads 2 times, or less, the height of car sides.
C	1 ea. pr. Items "B"	$\frac{5}{8}$ in. dia. rod, or 6 strands, No. 11 ga. wire.
D	4 per pile	6 strands, No. 11 ga. wire. Not required on intermediate piles or on inside ends of end piles when intermediate piles are tied to each other and to end piles, and end piles are tied per Item "E".
E	4 per pile	6 strands, No. 11 ga. wire. Not required on intermediate piles and on the inside ends of end piles when the intermediate piles are tied to each other and to end piles, nor on piles two times, or less, the height of car sides above floor.

See General Rules 4, 5, 10 and 15 for further details.

Sec. 2—Fig. 71

WIRE MESH OR BAR MATS, DIAGONALLY OR DISHED, 9 FT. HIGH OR LESS ABOVE FLOOR, WITH NO. 8 GAGE
HIGH TENSION WIRE—GONDOLA CARS

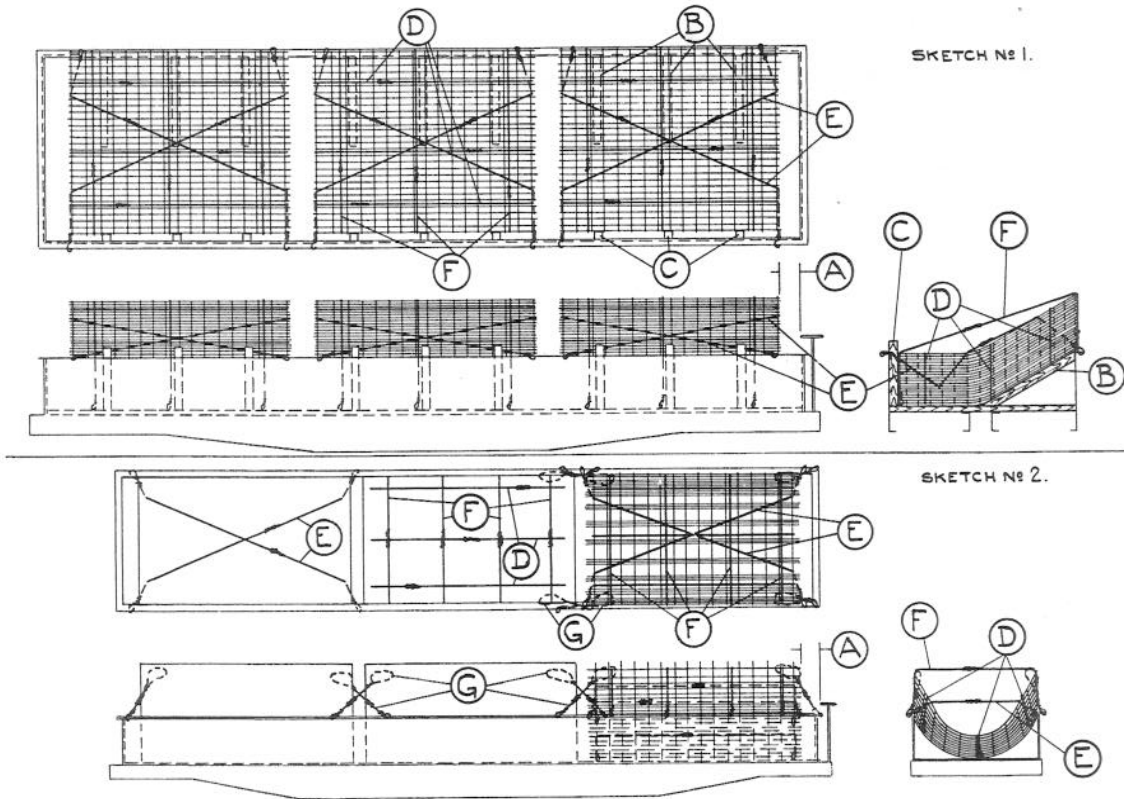

Item	No. of Pcs.	Description
A		Brake wheel clearance. See Fig. 2.
B	3 per pile Sketch 1	4 in. x 4 in., equally spaced. Bevel top and bottom ends to fully contact car sides and floor.
C	3 per pile Sketch 1	Stakes, hardwood, extending above top of car sides and equally spaced.
D	3 per pile Sketches 1 and 2	Thread one end of each wire through about 1 ft. of lower edge of pile and twist at least six times. Place opposite ends of wires over top of piles, machine tension and twist tie.
E	2 ties per pile Sketches 1 and 2	Place one end of wire through and twist six times at stake pocket nearest top of car side or hole in top side chord, then thread opposite end diagonally through upper portion and machine tension and twist tie both wires on top of load.
F	Pile 14 ft. 6 in. long or less, 3 Add 1 for each additional 8 ft. or less in length. Sketches 1 and 2	Thread one end of each wire through about 1 ft. of lower corner of pile and twist at least six times. Place opposite ends of wires over top of pile, machine tension and twist tie on top of pile.
G	4 per pile Sketch 2	Each to consists of two strands No. 7 gage wire. Locate, as shown, at each end of each side of pile threaded through mesh and attached at top of car sides.

Invert every other sheet to interlock cross bars, to stabilize and reduce height of load.

See General Rules 4, 5, 9, 10 and 15 for further details.

Sec. 2—Fig. 72

WIRE MESH OR BAR MATS, DIAGONALLY OR DISHED, WITH 2 IN. X .050 IN. HIGH TENSION BANDS—GONDOLA CARS

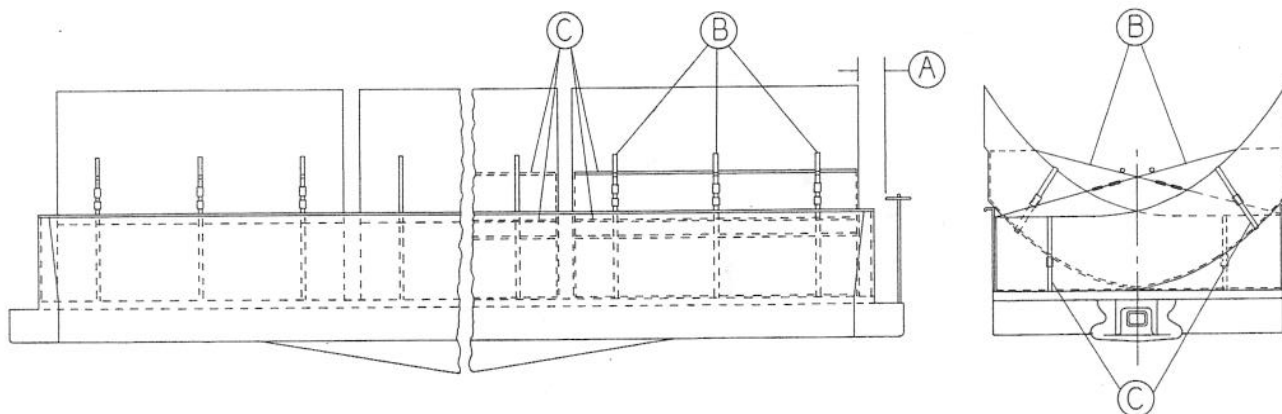

Item	No. of Pcs.	Description
A		Brake wheel clearance. See Fig. 2.
B	3 per pile.	Bands suitably spaced. Thread through mesh, as shown.
C	2 per pile.	Bands, suitably spaced, encircling entire pile.

Invert every other sheet to interlock cross bars, to stabilize and reduce height of load.

Reverse every other pile to stabilize load.

See General Rules 4, 5 and 15 for further details.

Sec. 2—Fig. 73

WIRE MESH OR BAR MATS, FLATWISE, 7 FT. HIGH OR LESS ABOVE CAR FLOOR, WITH 2 IN. X .050 IN. HIGH TENSION BANDS—GONDOLA CARS

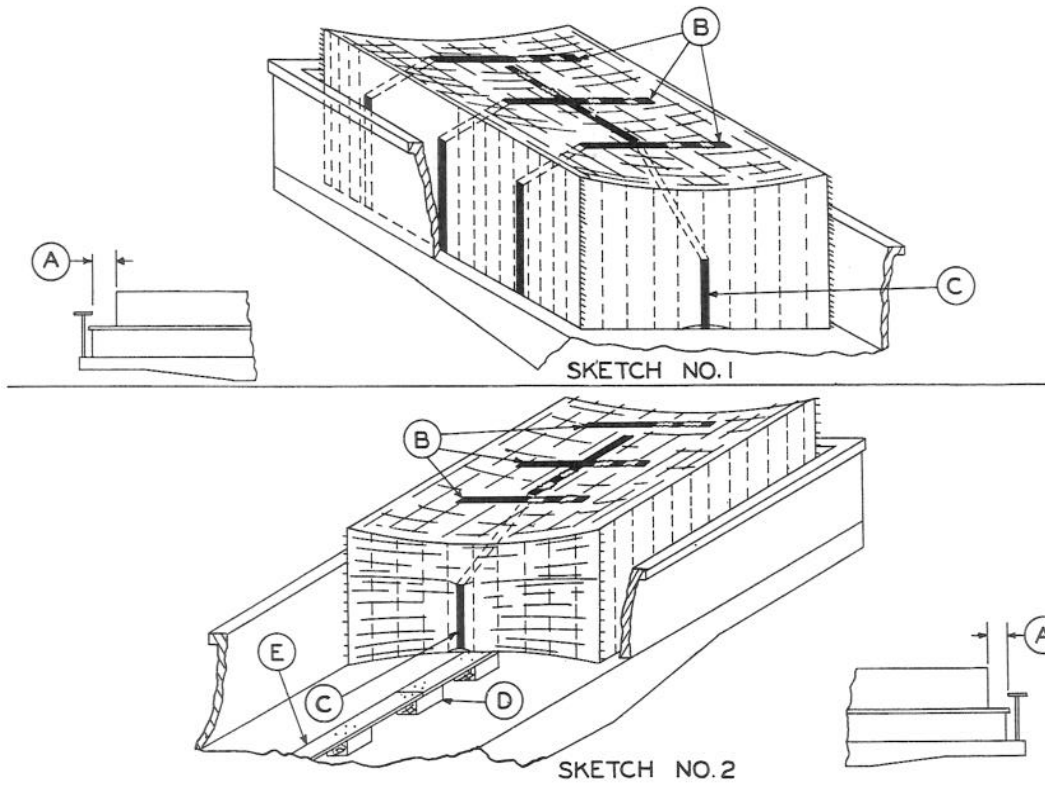

Item	No. of Pcs.	Description
A		Brake wheel clearance. See Fig. 2.
B	Pile 10 ft. 6 in. long or less, 2; pile over 10 ft. 6 in. to 16 ft. 6 in. long, 3; pile over 16 ft. 6 in. long, 4	Bands, equally spaced. Thread through mesh, as shown.
C	1 per pile	Bands. Thread through mesh, as shown.
D	3 per pile Sketch 2 only	4 in. x 4 in. x 8 in., or higher if necessary, to prevent load contacting car sides.
E	1 Sketch 2 only	1 in. x 4 in., hardwood, in one or more sections, nailed to Item "D" with 6-D nails.

Invert every other sheet to interlock cross bars, to stabilize and reduce height of load.

Sketch 2 covers loading of mesh as wide or wider than width of car.

See General Rules 4, 5, 9, 14 and 15 for further details.

ROLLED WIRE MESH, 30 IN. OR LESS IN DIAMETER, 8 FT. LONG OR LESS, LENGTHWISE, IN PYRAMIDAL FORM, WITH HIGH TENSION BANDS—GONDOLA CARS

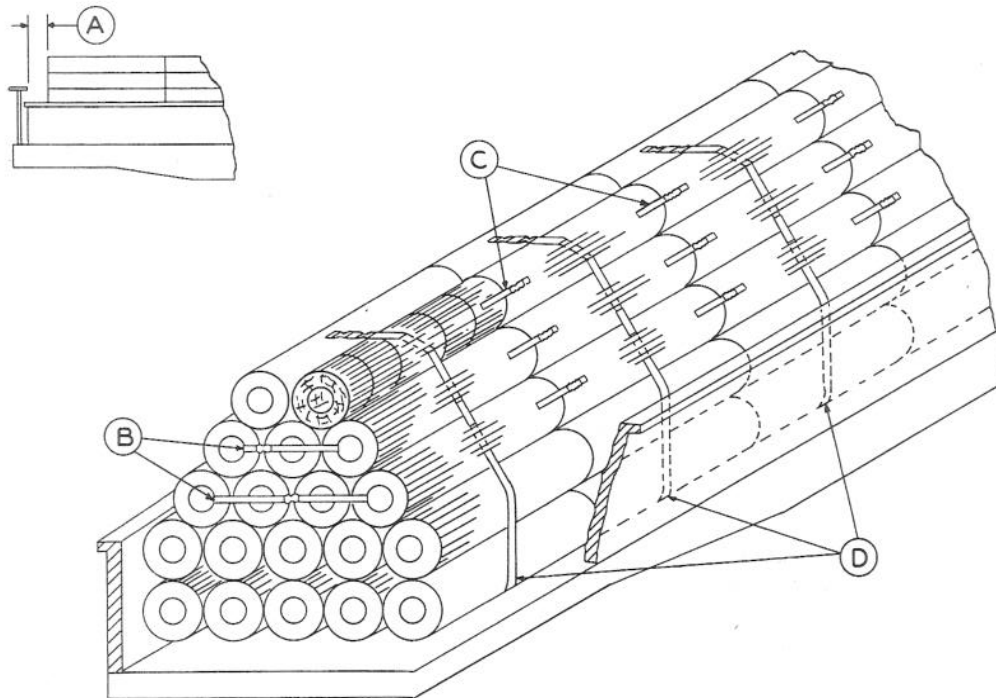

Item	No. of Pcs.	Description
A		Brake wheel clearance. See Fig. 2.
B	1 ea. row above car sides, except top row	$\frac{3}{4}$ in. x .035 in. bands. Thread through cores, as shown.
C	As required	$\frac{3}{4}$ in. x .035 in. bands. Place ends of rolls tightly together and thread bands through sides and near ends of outside rolls, as shown.
D	1 ea. pile	2 in. x .050 in. bands. Place around center of each pile, thread through outside rolls in each row above car sides, as shown.

The diameter of rolls forming the base of pyramid must not extend above the top of car sides. Space between piles and car sides must be filled in, at two points, on each side with vertical blocking secured to prevent displacement.

See General Rules 4, 5, 9, 14 and 15 for further details.

WIRE MESH IN ROLLS ON END, PYRAMIDED ON TOP, WITH WIRES. HEIGHT OF LOAD NOT TO EXCEED 10 FT.
6 IN. ABOVE FLOOR—GONDOLA CARS

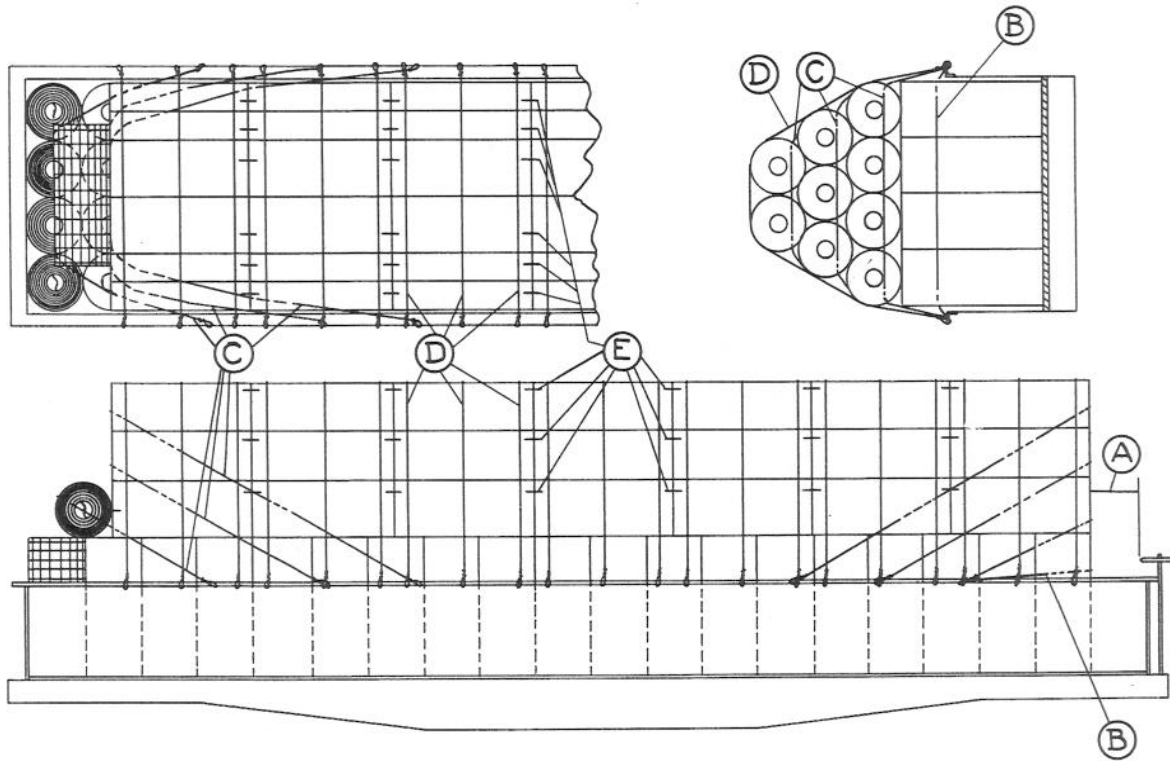

Item	No. of Pcs.	Description
A		Brake wheel clearance. See Fig. 2.
B	Rolls extending 2 ft. above top of car sides, 1 at ea. end of load Add 1 at ea. end for ea. additional 2 ft. or less in height	Each to consist of 2 strands $\frac{3}{16}$ in. dia. wire, or equivalent, twisted taut, full length. Secure to stake pockets or top side angles. Not required when load completely fills car and one-half or more of the height of rolls are below top of car sides.
C	2 ea. horizontal layer	Each to consist of 2 strands $\frac{3}{16}$ in. dia. wire, or equivalent, twisted taut, full length. Thread through corner rolls and secure to stake pockets or top side angles on opposite sides of car.
D	3 per pile	No. 8 ga. high tension wire. Pass across top of load and secure to stake pockets or top side angles on opposite sides of car.
E	As required	Each to consist of 2 strands No. 12 ga. wire, threaded through adjacent ends of horizontal rolls, twisted taut.

One horizontal crosswise roll may be loaded at end of lower horizontal layer and secured with one Item "C" and one Item "E" at each end.

Items "C", "D" and "E" not required when horizontal layers are omitted.

See General Rules 4, 5 and 15 for further details.

WIRE MESH IN ROLLS ON END, CROSSWISE LAYERS ON TOP, WITH 2 IN. X .050 IN. HIGH TENSION BANDS—
GONDOLA CARS

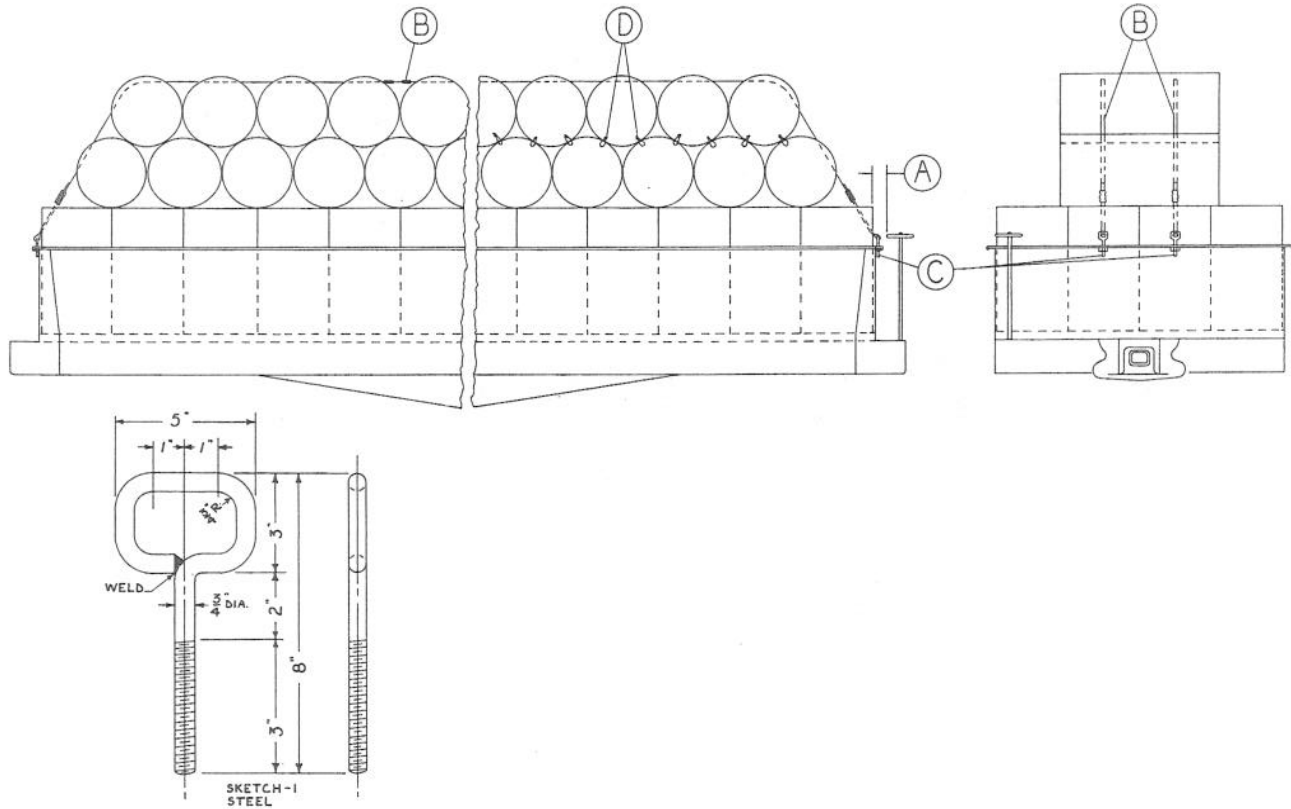

Item	No. of Pcs.	Description
A		Brake wheel clearance. See Fig. 2.
B	2	Bands, suitably spaced. Thread through mesh, as shown, and secure each to top end chord angles with Items "C".
C	2 ea. Item "B"	$\frac{3}{4}$ in. dia. threaded eye bolts, per Sketch 1.
D	As required.	Two strands No. 12 gage wire securing each roll in crosswise layers to layer underneath or to vertical portion of load. Not required when ends of vertical rolls extend sufficiently to prevent sidewise movement.

Vertical portion of load must occupy full floor space of car.

See General Rules 4, 5 and 15 for further details.

Sec. 2—Fig. 77

WIRE MESH OR BAR MATS, FLATWISE, 9 FT. HIGH OR LESS—GONDOLA CARS

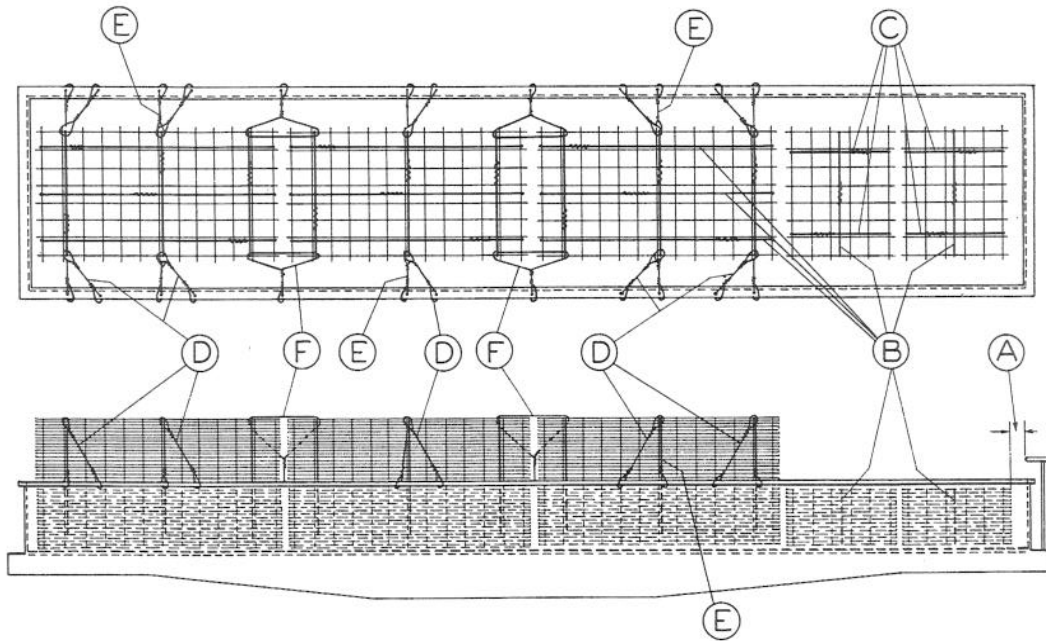

Item	No. of Pcs.	Description
A		Brake wheel clearance. See Fig. 2.
B	Pile 4 ft. high or less x 5 ft. wide or less; 1 Add 1 for each additional 3 ft. or less in width Pile over 4 ft. high by 6 ft. wide or less; 2 Add 1 for each additional 3 ft. or less in width	No. 8 gage high tension wire. Thread through lower portion of mesh at each side and seal at top of pile.
C	Pile 4 ft. high or less by 10 ft. long or less; 2 Add 1 for each additional 5 ft. or less in length Pile over 4 ft. high by 14 ft. 6 in. long or less; 3 Add 1 for each additional 5 ft. or less in length	No. 8 gage high tension wire. Thread through lower portion of mesh at each end and seal at top of pile.
D	Pile 7 ft. high or less; 4 per end pile; 2 per intermediate pile. Pile over 7 ft. high; 6 per end pile; 2 per intermediate pile	Each to consist of four strands No. 7 gage wire. Thread through mesh on each side at top of pile and attach to top of car sides.
E	Pile 7 ft. high or less; 2 Pile over 7 ft. high; 4 per end pile; 6 per intermediate pile	Each to consist of four strands No. 7 gage wire. Thread through mesh on each side at top of pile and attach to opposite car sides.
F	Between consecutive piles; 2	Each to consist of four strands No. 7 gage wire. Thread through mesh on each side at top of end to end piles and attach to top of car sides.

Invert every other sheet to interlock cross bars and stabilize load.
See General Rules 4, 5, and 15 for further details.

Sec. 2—Fig. 78

WIRE MESH OR BAR MATS, FLATWISE, LOAD 7 FT. HIGH OR LESS ABOVE FLOOR, WITH NO. 8 GAGE HIGH TENSION WIRE—FLAT OR GONDOLA CARS

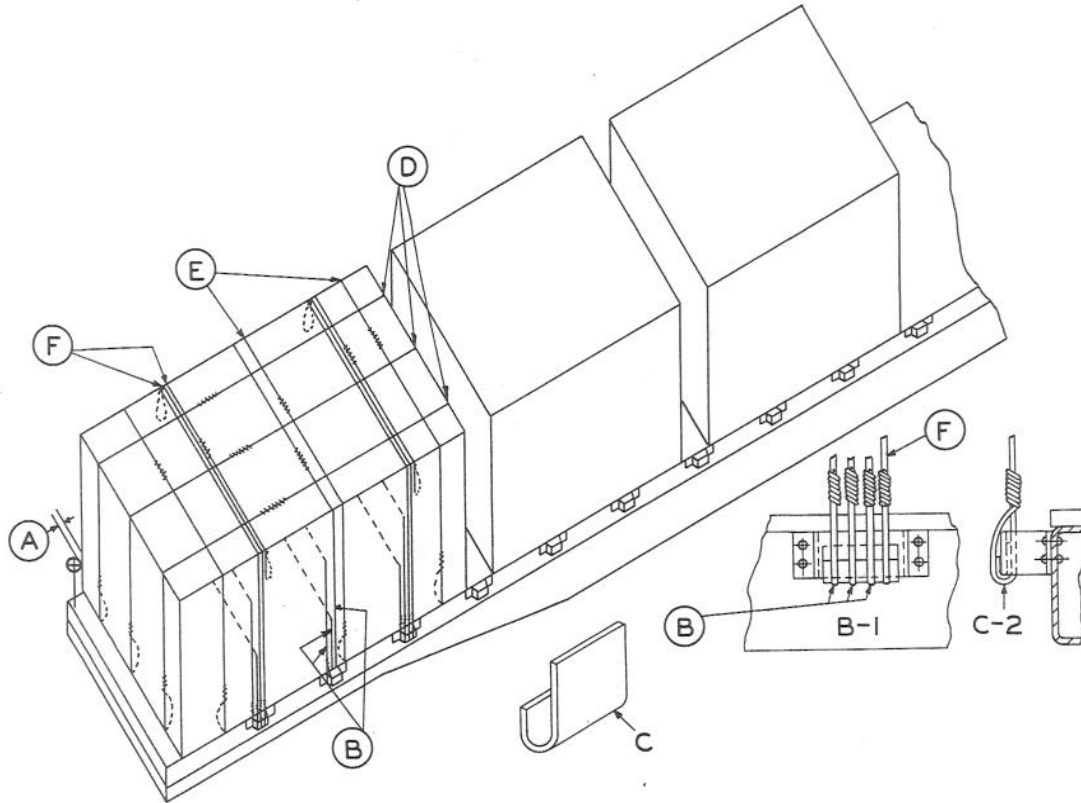

Item	No. of Pcs.	Description
A		Brake wheel clearance. See Fig. 2.
B	Pile 2 ft. 6 in. high or less, 8 ft. to 14 ft. 6 in. long, inclusive, 3 Add 1 for ea. additional 8 ft. or less in length Add 1 for ea. additional 18 in. or less in height at ea. location	Place one end of each wire through stake pockets, around Items "C", and twist at least 6 times, per sketch B-1. Place opposite ends of wires over top of pile. Items "B" required at only two locations on piles less than 8 ft. long.
C	4 or more per pile	4 in. wide, metal, strong enough to maintain 1/2 in. radius.
D	3 per pile	Thread one end of each wire through about 1 ft. of lower edge of pile and twist at least 6 times, per sketches B-1 and C-2. Place opposite ends of wires over top of pile.
E	Pile 14 ft. 6 in. long or less, 3 Pile over 14 ft. 6 in. long, 4	Thread one end of each wire through about 1 ft. of lower edge of pile and twist at least 6 times, per sketches B-1 and C-2. Place opposite ends of wires over top of pile.
F	4 per pile	Thread one end of each wire through mesh about 2 ft. from top of pile, and twist at least 6 times, per sketches B-1 and C-2. Pass wire over top, down opposite side of pile, around stake pocket and Item "C".

Invert every other sheet to interlock cross bars, to stabilize and reduce height of load.

An alternate method consisting of a washer attachment may be substituted for Sketches B-1 or C-2.

See General Rules 4, 5 and 15 for further details.

WIRE MESH OR BAR MATS, FLATWISE, 7 FT. HIGH OR LESS ABOVE FLOOR, WITH HIGH TENSION BANDS AND MECHANICAL BRAKEMAN—FLAT OR GONDOLA CARS

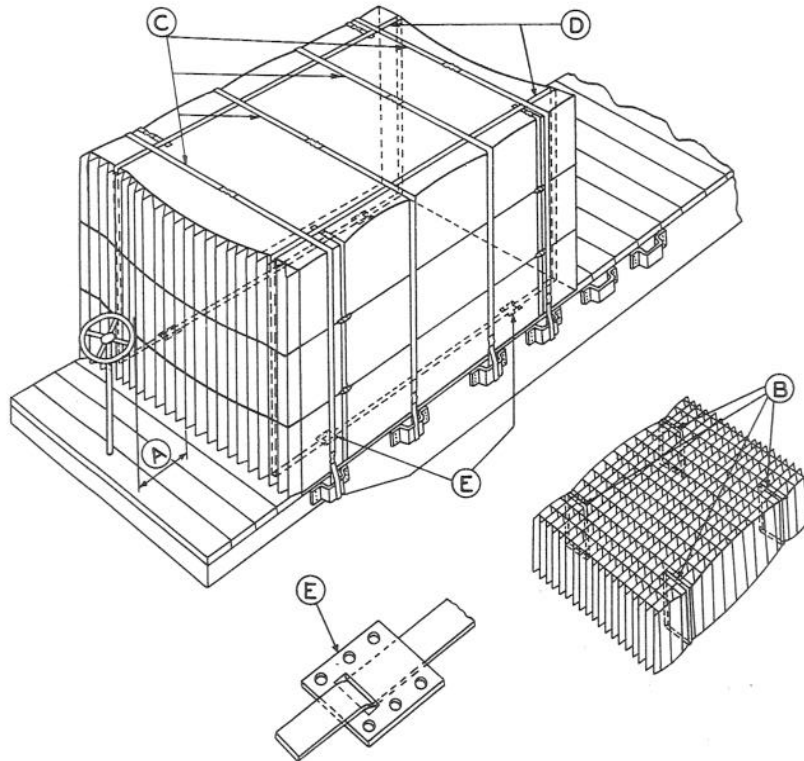

Item	No. of Pcs.	Description
A		Brake wheel clearance. See Fig. 2.
B	Pile 20 ft. long or less, 4 Add 2 bands for each additional 10 ft. or less in length	1 1/4 in. x .035 in. bands, encircling portion of bundle, height of which must not exceed 30 in. after bands have been tensioned.
C	Pile 8 ft. long or less, 2 Pile over 8 ft. long to 14 ft. 6 in. inclusive, 3 Add 1 band for each additional 4 ft. or less in length	2 in. x .050 in. bands, attached to stake pockets. May be threaded through mesh.
D	2 per pile	2 in. x .050 in. bands, encircling entire pile, and passing through Items "E". Locate about 18 in. from outside of pile. May be threaded through mesh.
E	2 ea. Item "D"	Mechanical brakeman, each secured with 1/32 in. x 1 1/4 in. drive screws, located about 2 ft. from ends of load.

When lengthwise bars or wires comprising mesh or bar mats are not of uniform diameter throughout, add two 1 1/4 in. x .035 in. crosswise bands around the two lower lifts to prevent side shifting of piles.

Invert every other sheet to interlock cross bars, to stabilize and reduce height of load.

See General Rules 4, 5 and 15 for further details.

WIRE MESH OR BAR MATS, FLATWISE, 7 FT. HIGH OR LESS ABOVE FLOOR, WITH 2 IN. X .050 IN. HIGH TENSION BANDS—FLAT CARS

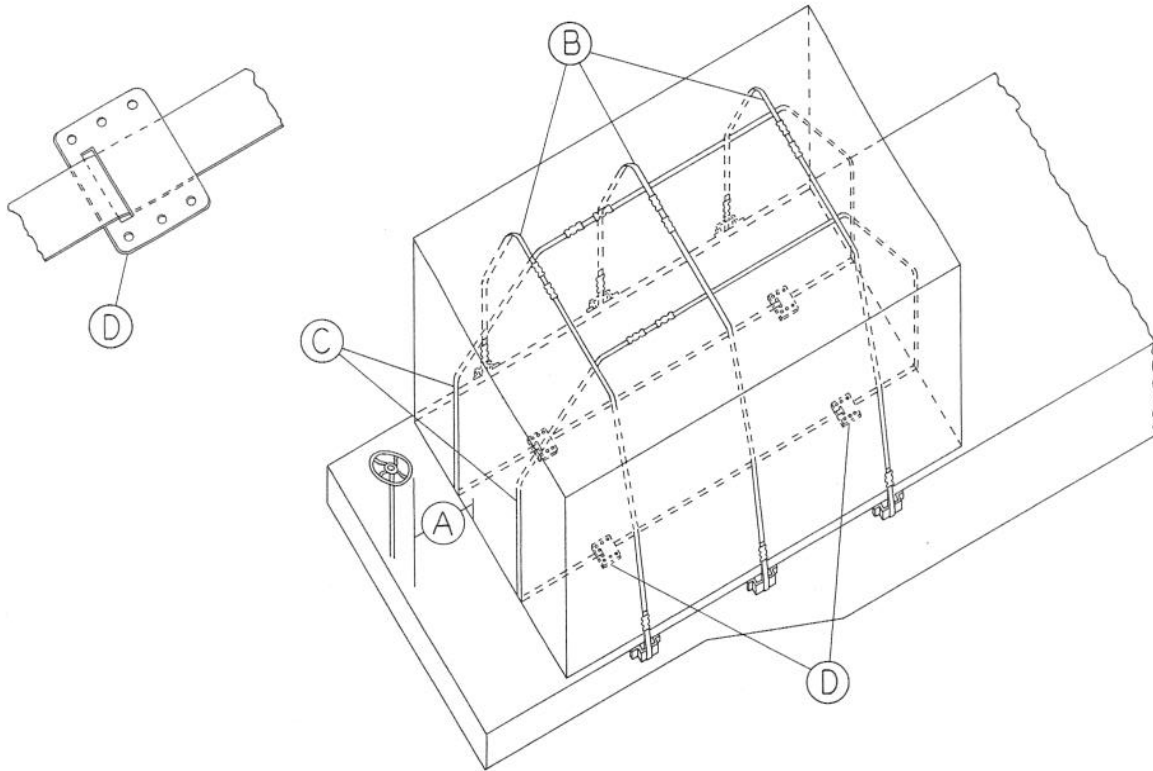

Item	No. of Pcs.	Description
A		Brake wheel clearance. See Fig. 2.
B	Pile 15 ft. long or less, 3. Add 1 band for each additional 4 ft. or less in length.	Bands, suitably spaced. Thread through mesh, as shown, and pass through stake pockets.
C	2 per pile	Bands, suitably spaced encircling entire pile. Thread through mesh, as shown, and pass through Items "D".
D	2 ea. Item "C".	Mechanical brakeman. Locate each about 2 ft. from ends of pile and secure with six $\frac{1}{32}$ in. x $1\frac{3}{4}$ in. drive screws.

Invert every other sheet to interlock cross bars, to stabilize and reduce height of load.

See General Rules 4, 5 and 15 for further details.

WIRE MESH OR BAR MATS, FLATWISE, 8 FT. HIGH OR LESS ABOVE FLOOR, WITH 2 IN. X .050 IN. HIGH TENSION BANDS—FLAT CARS.

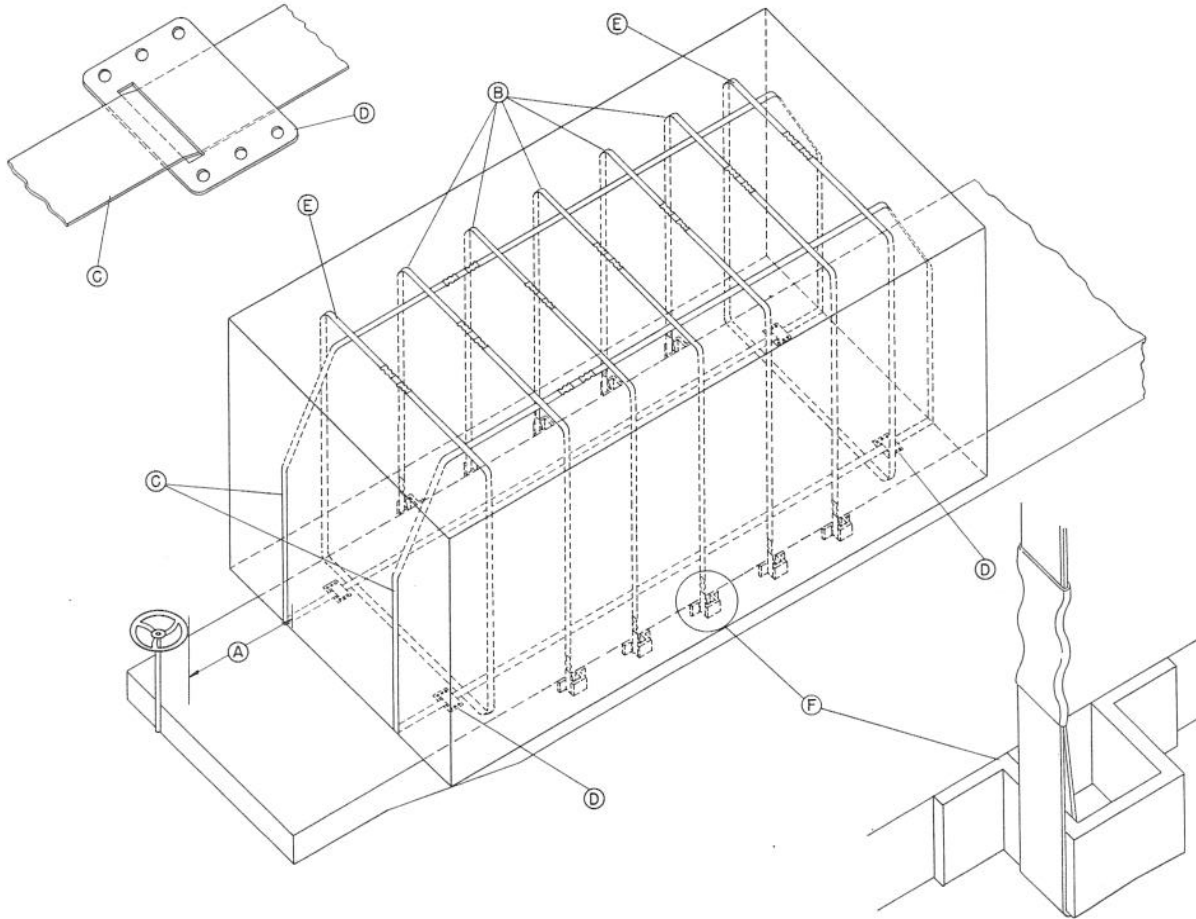

Item	No. of Pcs.	Description
A		Brake wheel clearance. See Fig. 2.
B	Pile 15 ft. long or less, 5. Add 1 band for each additional 4 ft. or less in length.	Bands, suitably spaced. Thread through mesh, as shown, and pass through stake pockets.
C	2 per pile.	Bands, suitably spaced encircling entire pile. Thread through mesh, as shown, and pass through Items "D".
D	2 ea. Item "C".	Mechanical brakeman. Locate each about 2 ft. from ends of pile and secure with six $\frac{1}{2}$ in. x $1\frac{3}{4}$ in. drive screws.
E	2 per pile.	Bands, crosswise encircling entire pile, spaced approximately 2 to 3 ft. from each end of pile. Thread through mesh, as shown, and place over Items "C".

See General Rules 4, 5 and 15 for further details.

WIRE MESH OR BAR MATS, 7 FT. HIGH OR LESS ABOVE FLOOR, FLATWISE, WITH RODS AND CLAMPS—FLAT CARS

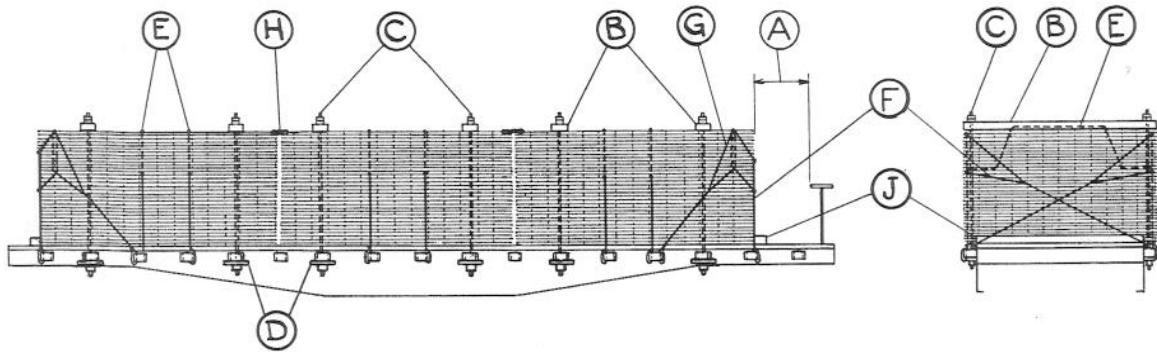

Item	No. of Pcs.	Description
A		Brake wheel clearance. See Fig. 2.
B	Pile 16 ft. long or less, 1 Add 1 for each additional 10 ft. or less in length	4 in. x 4 in., hardwood, ½ in. dia. bolt with washers, at each end to prevent splitting.
C	1 pr. each Item "B"	⅛ in. dia. rods, with nuts and washers, long enough to extend through Item "B", stake pocket and Item "D".
D	1 each Item "C"	½ in. x 4 in. x 10 in. plate.
E	Pile 16 ft. long or less, 2 Add 1 for each additional 10 ft. or less in length	2 strands, No. 11 ga. wire, passed through mesh about as shown, twisted taut, and secured to stake pockets on each side of car.
F	4 per pile	4 strands, No. 11 ga. wire, twisted taut.
G	4 per pile	4 strands, No. 11 ga. wire, twisted taut.
H	As required	4 strands, No. 11 ga. wire, laced through top corners of piles as shown. Permitted as a substitute for Items "F" and "G" between piles only when distance between piles is 6 in. or less.
J	2 per pile	4 in. x 4 in., hardwood, length equal to width of load, nailed to floor with 60-D nails.

Invert every other sheet to interlock cross bars, to stabilize and reduce height of load.

When lengthwise bars or wires comprising mesh or bar mats, are not of uniform diameter throughout, causing sag in center, apply sufficient blocking between layers or lifts to level off load.

See General Rules 4, 5, 9, 14 and 15 for further details.

MOUNTED WHEELS—GONDOLA CARS

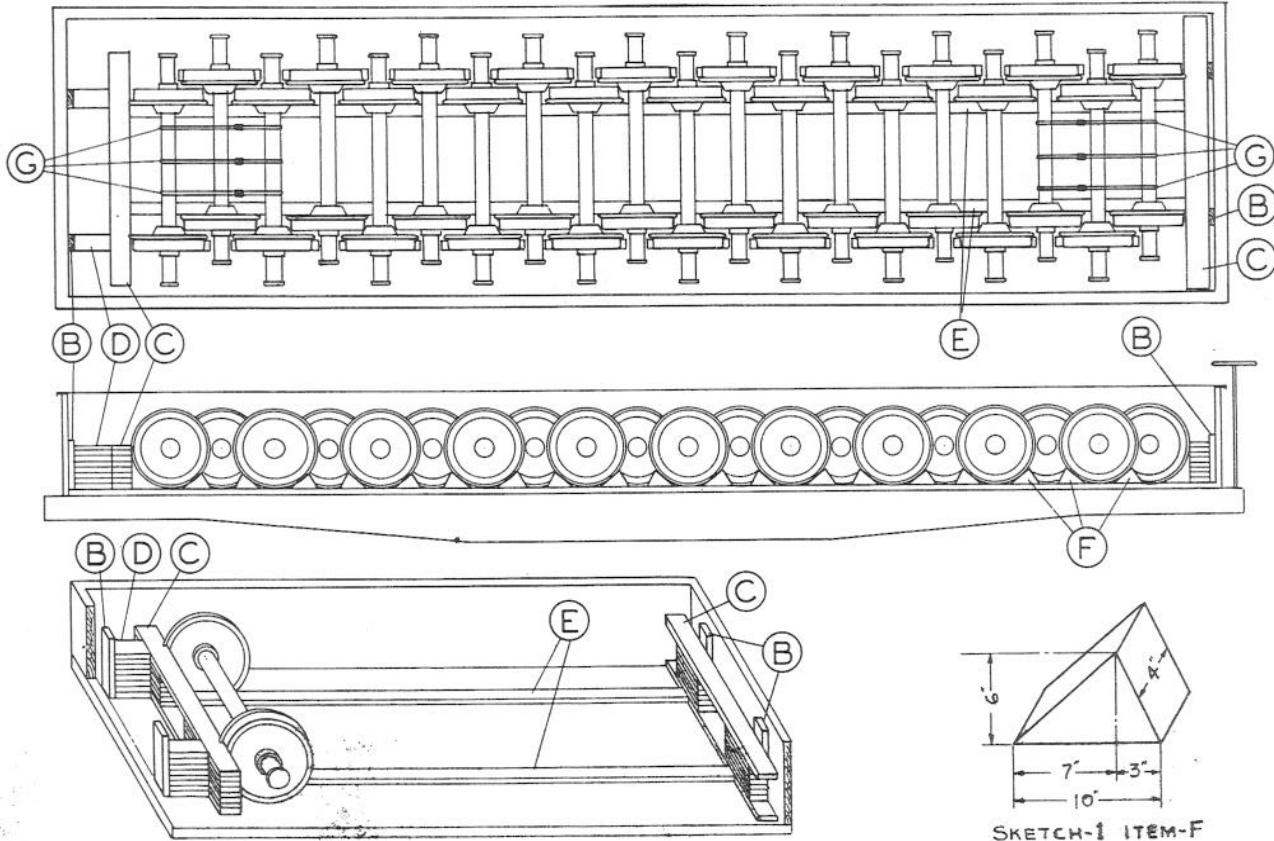

Item	No. of Pcs.	Description
A		Brake wheel clearance. See Fig. 2.
B	2 ea. end of load	1 3/4 in. x 8 in. x 18 in., hardwood, securely wedged between Items "D" or "C" and end of car.
C	As required	1 3/4 in. x 7 in., hardwood, long enough to extend 12 in. beyond outside face of wheels, height equal to 1/2 the dia. of wheels or a maximum of 16 in. Nail to floor and to each other with ten 20-D nails in each. Toe-nail top piece to Items "B" with two 20-D nails at each location where Items "D" are not used. Pieces contacting flanges must be cut to fit flange so as to provide full bearing on wheel tread. Substitute, if desired, the intermediate pieces with 1 3/4 in. x 7 in. x 24 in. pieces, centered against wheel. Nail to bottom Item "C" and to each other with three 30-D nails in each.
D	As required 1 end only	1 3/4 in. x 6 in., hardwood, long enough to completely fill space between Items "B" and "C", height equal to Items "C". Locate against Items "C" at center of wheel and nail to floor and to each other with three 20-D nails in each. Top piece must be toe-nailed to Items "B".
E	2 per load	2 in. x 3 in., hardwood, full length of load. Locate against inside faces of inside wheels and nail each to floor with 20-D nails spaced about 18 in. apart.
F	2 ea. outside wheel	4 in. x 6 in. x 10 in., hardwood, per Sketch 1. Locate against tread of wheel and nail each to floor with three 40-D nails.
G	3 ea. end of load	1 1/4 in. x .035 in. high tension bands, equally spaced, encircling 3 end axles. Substitute, if desired, two 3/4 in. dia. rods, long enough to tie three pair of wheels together, and two 1/2 in. x 2 1/2 in. x 10 in. clamps.

See General Rules 4, 5, 9, 14 and 15 for further details.

Sec. 2—Fig. 84

MOUNTED WHEELS LESS THAN 42 IN. IN DIAMETER—FLAT OR GONDOLA CARS

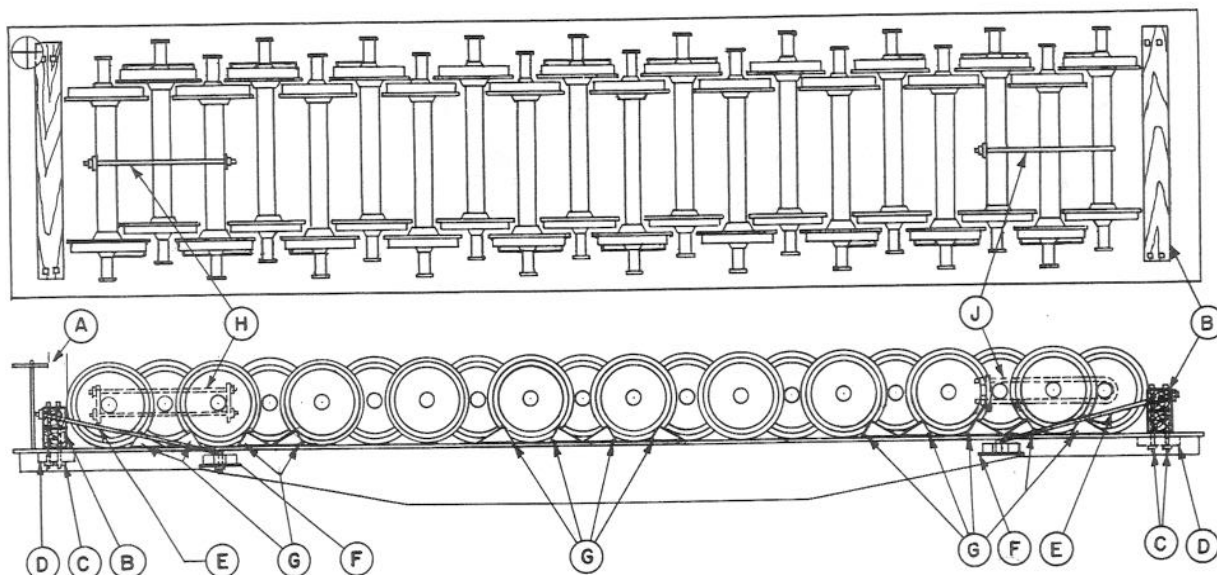

Item	No. of Pcs.	Description
A		Brake wheel clearance. See Fig. 2.
B	1 ea. end of load	Flat cars.—8 in. wide, 16 in. high, hardwood. Gondola cars.—6 in. wide, 16 in. high, hardwood. Must be long enough to extend 6 in. beyond outside face of wheels.
C	4 ea. Item "B"	$\frac{3}{4}$ in. dia. bolts, through Item "B", floor and Item "D".
D	2 ea. end of load	4 in. x 4 in. x 18 in., hardwood, or $\frac{1}{2}$ in. x 4 in. x 18 in. plate.
E	2 ea. Item "B"	$\frac{7}{8}$ in. dia. rods, with washers, through upper portions of Items "B", near each end and Item "F" under stake pocket at a suitable angle. Not required for gondola cars.
F	1 ea. Item "E"	$\frac{1}{2}$ in. x 4 in. x 10 in. plate. Not required for gondola cars.
G	As required	4 in. x 5 in. x 8 in., hardwood, each secured with three 20-D nails.
H	3 ea. end of load.	$1\frac{1}{4}$ in. x .035 in. high tension bands, equally spaced, encircling 3 end axles. Substitute, if desired, two $\frac{3}{4}$ in. dia. rods, long enough to tie three pair of wheels together, and two $\frac{1}{2}$ in. x $2\frac{1}{2}$ in. x 10 in. clamps.

See General Rules 4, 5, 9, 14 and 15 for further details.

MOUNTED WHEELS—DOUBLE DECKED—FLAT OR GONDOLA CARS

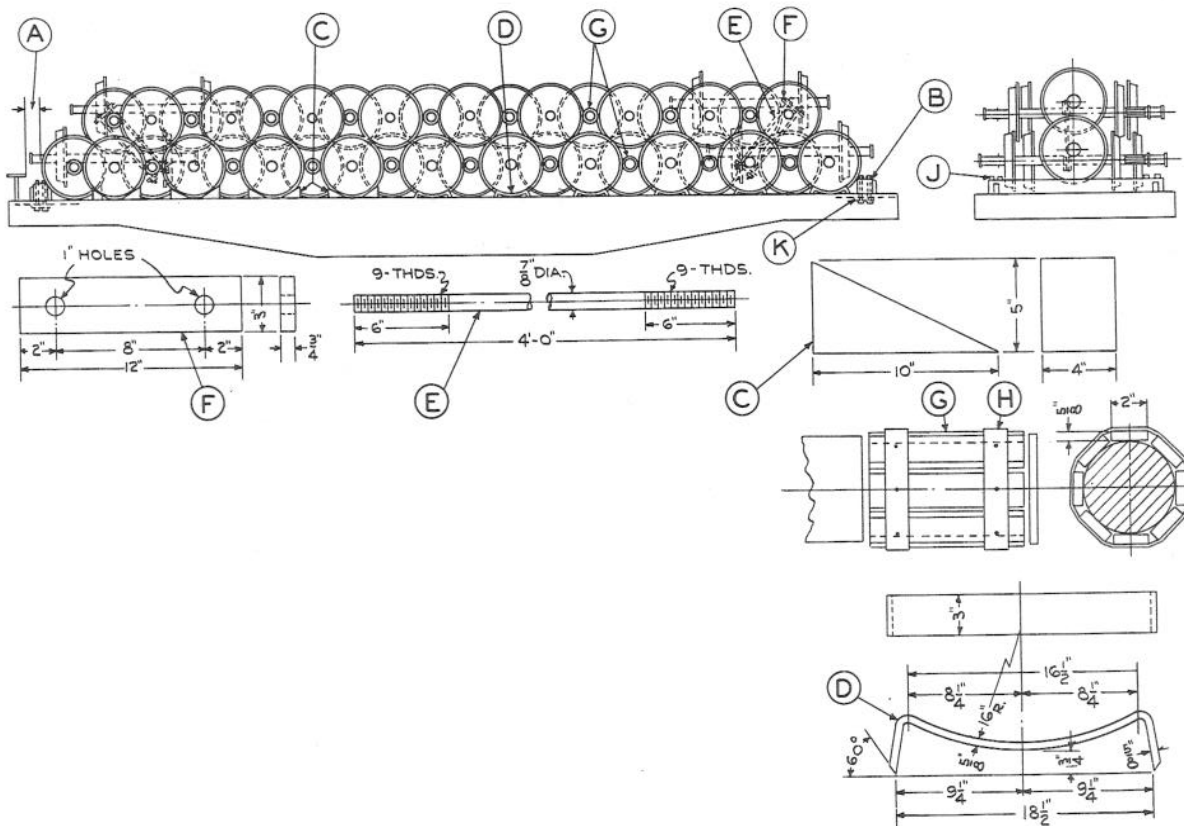

Item	No. of Pcs.	Description
A		Brake wheel clearance. See Fig. 2.
B	2	Flat cars.—8 in. wide, 8 in. high, hardwood, full width of load. Gondola cars.—6 in. wide, 8 in. high, hardwood, full width of load. Must be backed up with two 4 in. x 5 in. hardwood stakes each end. When stake pockets are not available, use tapered blocks, secured with 20-D nails.
C	2 ea.	outside wheel 4 in. x 5 in. x 10 in., secured to floor with 30-D nails. Item "D" may be substituted.
D	1 ea.	outside wheel 5/8 in. x 3 in. x 18 1/2 in. Item "C" may be substituted.
E	4	7/8 in. dia. x 4 ft. rods. Substitute, if desired, four 1 1/4 in. x .035 in. high tension bands.
F	4	3/4 in. x 3 in. x 12 in. plate.
G	To protect journal	Hardwood strips, 5/8 in. x 2 in., length of journal.
H	2 per journal	20 ga. 1 1/4 in. wide, metal band, nailed to Item "G".
J	8	3/4 in. dia. bolts through Item "B" and floor.
K	4	4 in. x 4 in. x 18 in. hardwood, or 1/2 in. x 4 in. x 18 in. plates.

See General Rules 4, 5, 9, 14 and 15 for further details.

Sec. 2—Fig. 86

MOUNTED WHEELS, LOADED CROSSWISE—GONDOLA CARS

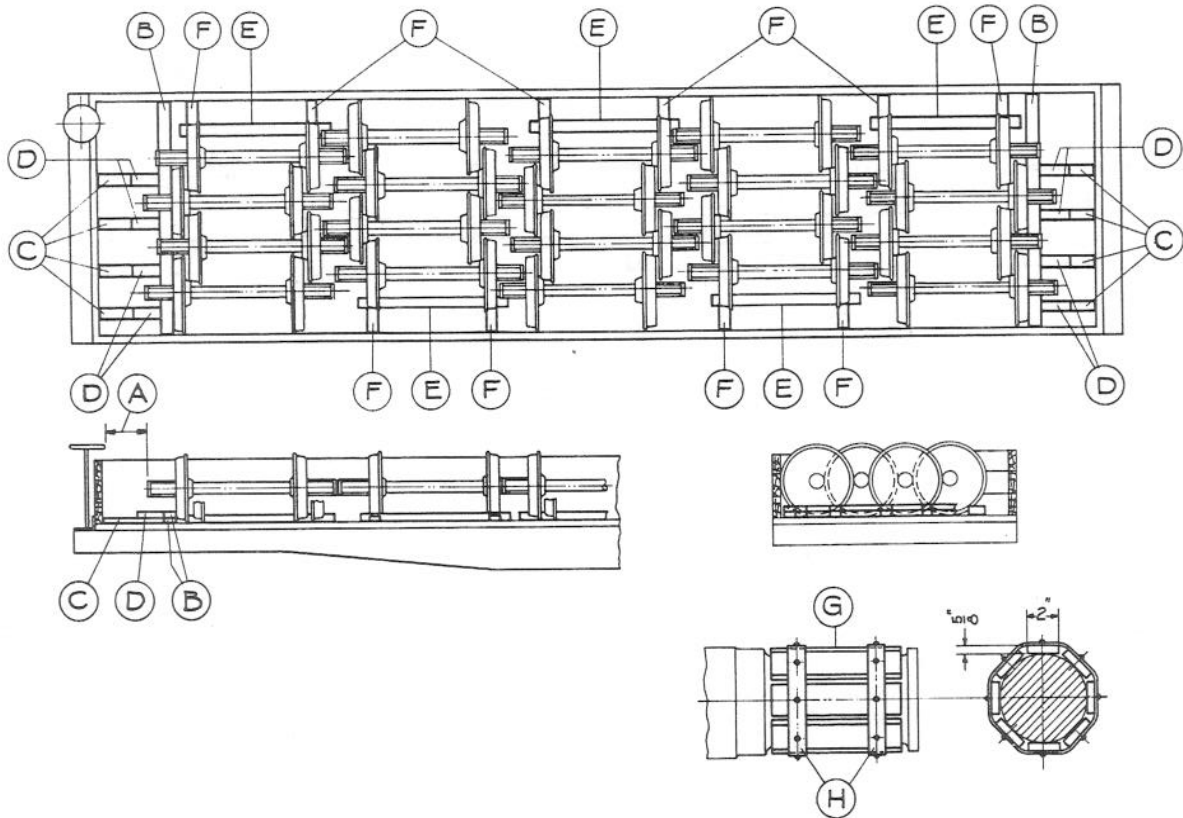

Item	No. of Pcs.	Description
A		Brake wheel clearance. See Fig. 2.
B	2 ea. end of load	Each to consist of two pieces 2 in. x 4 in., hardwood, length about equal to width of car. Nail lower pieces to floor with 30-D nails spaced about 12 in. apart, and top pieces to those below in like manner.
C	4 ea. end of load	2 in. x 4 in., hardwood, long enough to extend from Item "B" to end of car. To be suitably located and nailed to floor with six 30-D nails in each.
D	1 ea. Item "C"	2 in. x 4 in. x 12 in., hardwood. Locate on top of Item "C", with one end against Item "B". Nail to Item "C" with four 30-D nails in each.
E	1 ea. row of wheels	3 in. x 4 in. x 6 ft. long or over. Locate against wheels and toe-nail to floor with 40-D nails spaced about 12 in. apart.
F	2 ea. Item "E"	2 in. x 4 in., long enough to extend from Item "E" to car side. Locate opposite to wheel treads and nail each to floor with five 20-D nails.
G	To protect journal	Hardwood strips, 5/8 in. x 2 in., length of journal.
H	2 per journal	20 ga., 1 1/4 in. wide, metal bands, nailed to Item "G".

Wheels in each row must be of same nominal diameter.

See General Rules 4, 5, 9 and 14 for further details.

SCRAP, ETC., EXTENDING ABOVE CAR SIDES—GONDOLA CARS

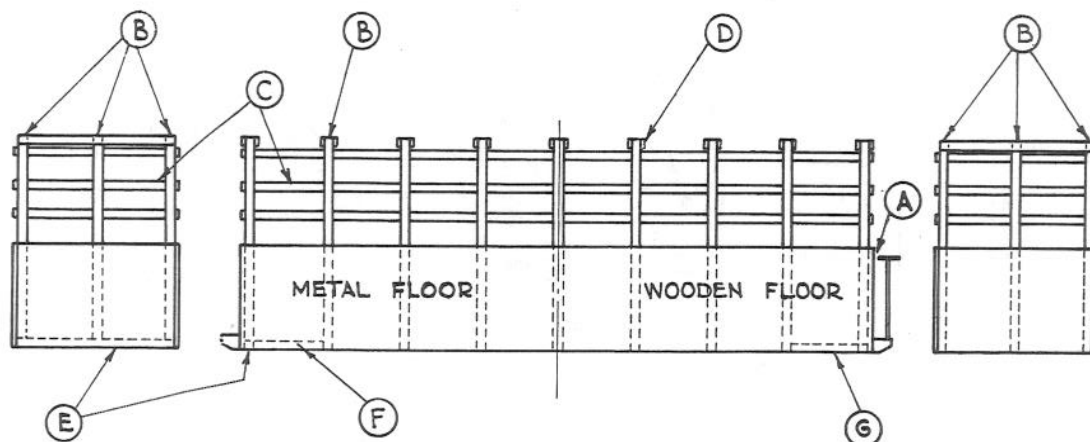

Item	No. of Pcs.	Description
A		Brake wheel clearance. See Fig. 2.
B	To suit	Stakes, hardwood, spaced not over 5 ft. apart. Substitute, if desired, the following for each stake, Item "B": (a) One 2 in. dia. pipe, or 1 bar of equal strength. (b) Two 1½ in. dia. pipe, located side by side, or 2 bars equal to the strength of the combined strength of the 2 pieces of pipe. (c) One channel, I beam, rail, and similar shapes of equal strength, or 2 such smaller parts, located side by side, when the combined strength of both is equal to the strength of a stake. They must extend from car floor to about 4 in. above top of load and be tied across top of load with 6 strands, of No. 11 gage wire, Items "D". Material considerably weakened by rust or corrosion must not be used for this purpose.
C	To suit	1 in. thick, width to suit, nailed to inside of Items "B". Must be close enough together to prevent loss of lading. Substitute, if desired, metal parts of sufficient area to fully protect load. Such parts must be strong enough to prevent load from forcing them outward and they must be placed or secured so as to prevent displacement.
D	1 ea. Pr. "B"	6 strands, No. 11 gage wire.
E	1 ea. end	4 in. x 4 in., secured by nailing end and end corner stakes with 20-D nails. Use on steel floors only.
F	2 ea. end	4 in. x 4 in., length to suit, nailed to Items "B" and "E" with 20-D nails. Use on steel floors only.
G	3 ea. end	2 in. x 6 in. x 18 in., nailed to floor with six 20-D nails.

Borings, turnings, loose tin and sheet steel cuttings not over ¼ in. thick, of a nature that will not cause derailment by dropping on track or lodging in frogs or switches, may be loaded in hopper or drop-door gondola cars without boarding over door openings as specified in Rule 20.

Unbaled scrap tin, or similar material, loaded above car sides liable to displacement by suction, or material originally loaded even with or below top of car sides, and of such a nature that it can work above top of car sides in transit, must be secured to prevent displacement.

Items "B" to "G" inclusive, may be substituted with 2 strands, No. 11 gage wire, in cases where load extends 6 in. or less above top of car side or ends, or when pyramided from top of car sides to not more than 18 in. at center of car and wired down so as to prevent scrap from projecting beyond car sides or ends. Wire must be spaced not more than 3 ft. apart and be secured to stake pockets or car sides.

Large scrap, such as structural steel, plates, pipe, rods, boilers, tanks, machines, wheels, etc., must be secured as per other figures specified for such material.

Items "B" and "C" not required for light material 8 ft. long or over, such as tin, when properly baled with wire, or high tension bands, provided not less than ½ the height of top bales extends below top of car sides, provided height of load above top of car sides does not exceed 4 ft.

See General Rules 4, 5, 9, 14 and 15 for further details.

Sec. 2—Fig. 88

MANNER OF LOADING IRON ORE, LIMESTONE AND SIMILAR MATERIAL—HOPPER & GONDOLA CARS

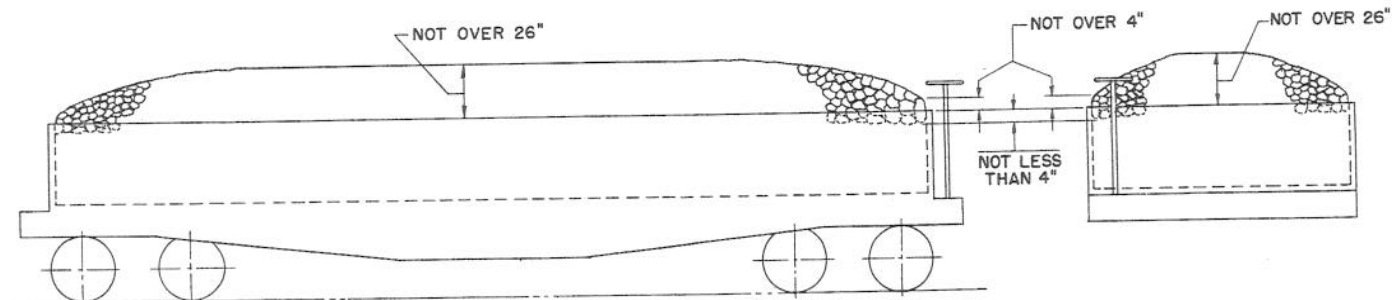
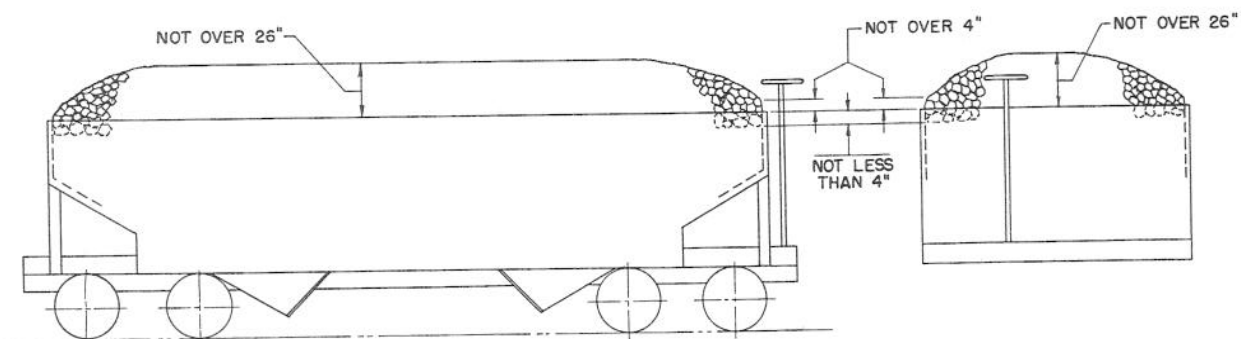
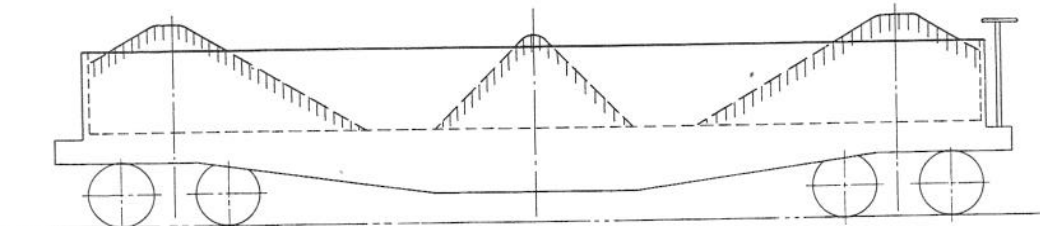
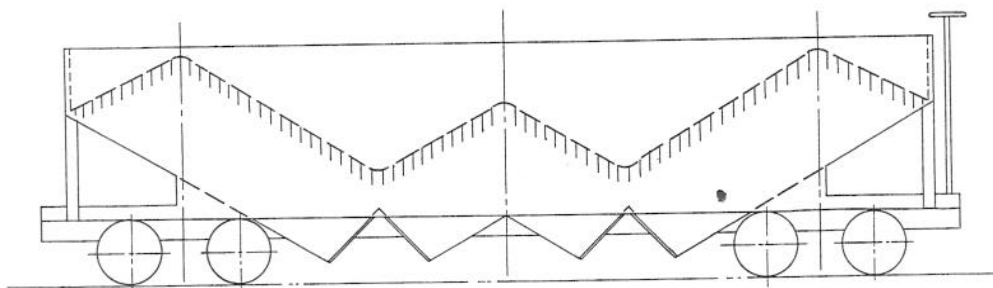
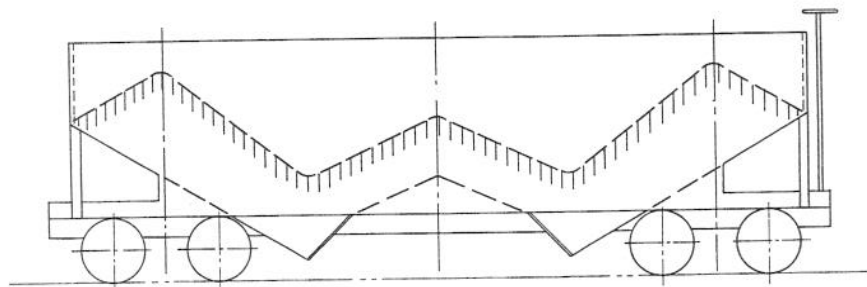

MANNER OF LOADING COAL AND COKE—HOPPER AND GONDOLA CARS.

SECTION No. 2

PART 2

RULES GOVERNING

THE

**Loading of Pipe
On Open Top Cars**

Sec. 2—Fig. 120

WROUGHT IRON AND STEEL PIPE, 26 INCHES OR LESS IN DIAMETER, WITH WIRE—FLAT CARS

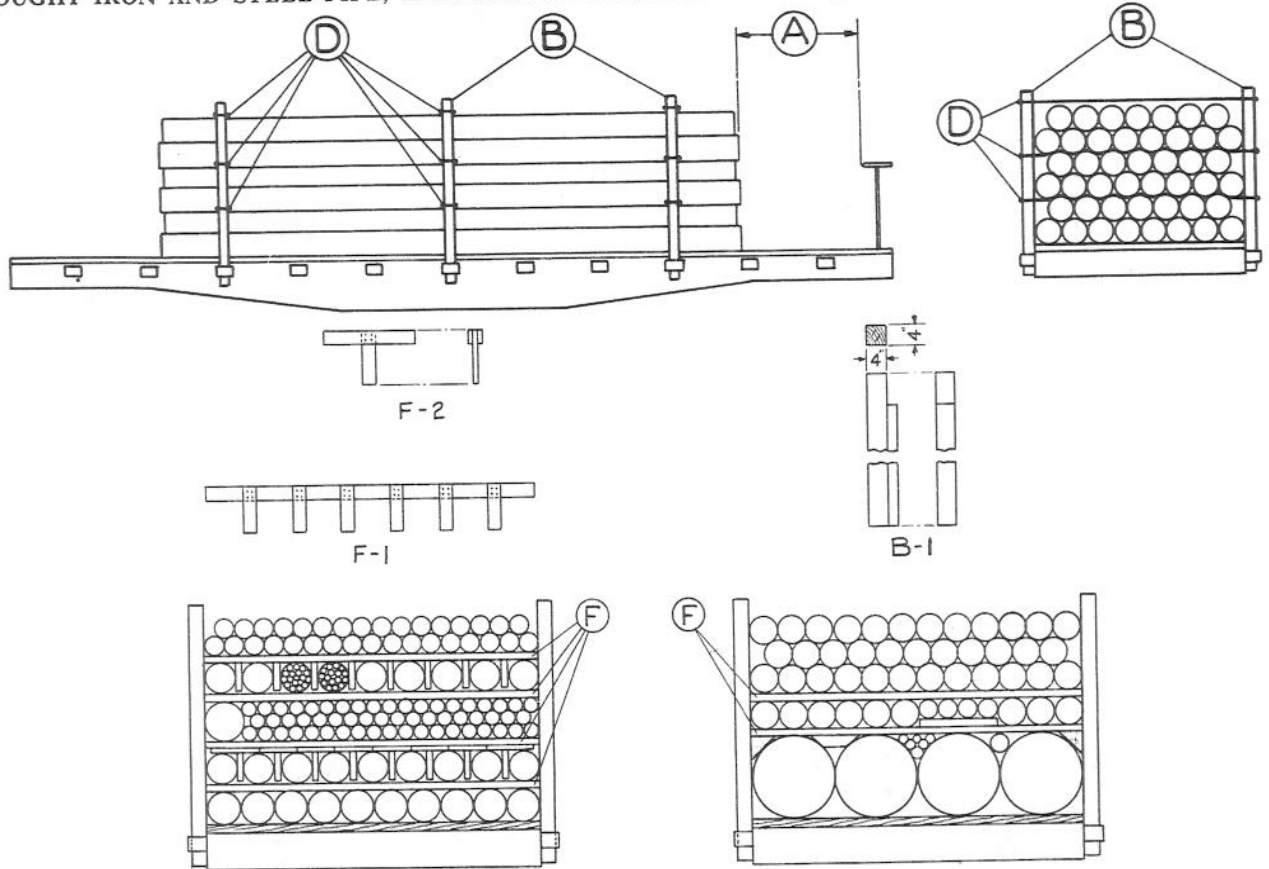

SKETCH. No. 1

SKETCH. No. 2
Description

Item	No. of Pcs.	Description
A		Brake wheel clearance. See Fig. 2.
B	Pile 4 ft. high or less: 3 pr. per pile 25 ft. long or less; 4 pr. per pile over 25 ft. to 34 ft. long, inclusive; 5 pr. per pile over 34 ft. long. Pile over 4 ft. high: 4 pr. per pile 25 ft. long or less; 5 pr. per pile over 25 ft. to 34 ft. long, inclusive; 6 pr. over 34 ft. long.	Stakes, hardwood, spaced as equally as possible. Fill space between pipe and stakes by nailing suitable fillers to inside face of stakes, per Sketch B-1.
C		VACANT.
D	Each pr. Items "B" as required	6 strands, No. 11 ga. wire. Space lower wire not more than 20 in. from floor and intermediate wires not more than 20 in. apart, except for pipe over 20 in. dia., use wire between each successive layer. Place wire across top of pile.
E		VACANT.
F	3 between one or more successive layers. Use only when necessary for separation of pipe.	2 in. x 4 in., hardwood, length equal to width of load, not to extend beyond inside face of stakes, equally spaced. For pipe 10 in. or more in dia., nail a 2 in. x 4 in. block, length to suit, located midway between both ends, with three 20-D nails. On pipe less than 10 in. dia., size of block to be as large as possible, located in same manner. Place one pipe directly above the one below, if possible, otherwise use supports underneath Items "F", per Sketch 2, for spaces over 10 in. between pipe and over 4 in. between pipe and inside of Items "B", measured crosswise. Suitable vertical separators, per Sketch F-1, nailed to Item "F", or "T" shaped separators, per Sketch F-2, may be used as per Sketch 1.

Ends of pipe must not be less than 18 in. from ends of car.

Couplings must be staggered and must not rest on each other.

Wire, flat metal strips or heavy paper may be placed between pipe where separations are required for identification purposes.

Tubular steel poles, tapered or made of two or more sections of different diameters, must be loaded with the large and small ends alternated in each layer. Use suitable fillers when necessary to equalize load.

Pipe 12 ft. long or less must not be loaded on flat cars. Small diameter pipe must not be loaded inside larger diameter pipe.

See General Rules 4, 5, 9, 10, 14 and 15 for further details.

Sec. 2—Fig. 121

WROUGHT IRON AND STEEL PIPE, 26 IN. OR LESS IN DIAMETER, WITH HIGH TENSION BANDS—FLAT CARS

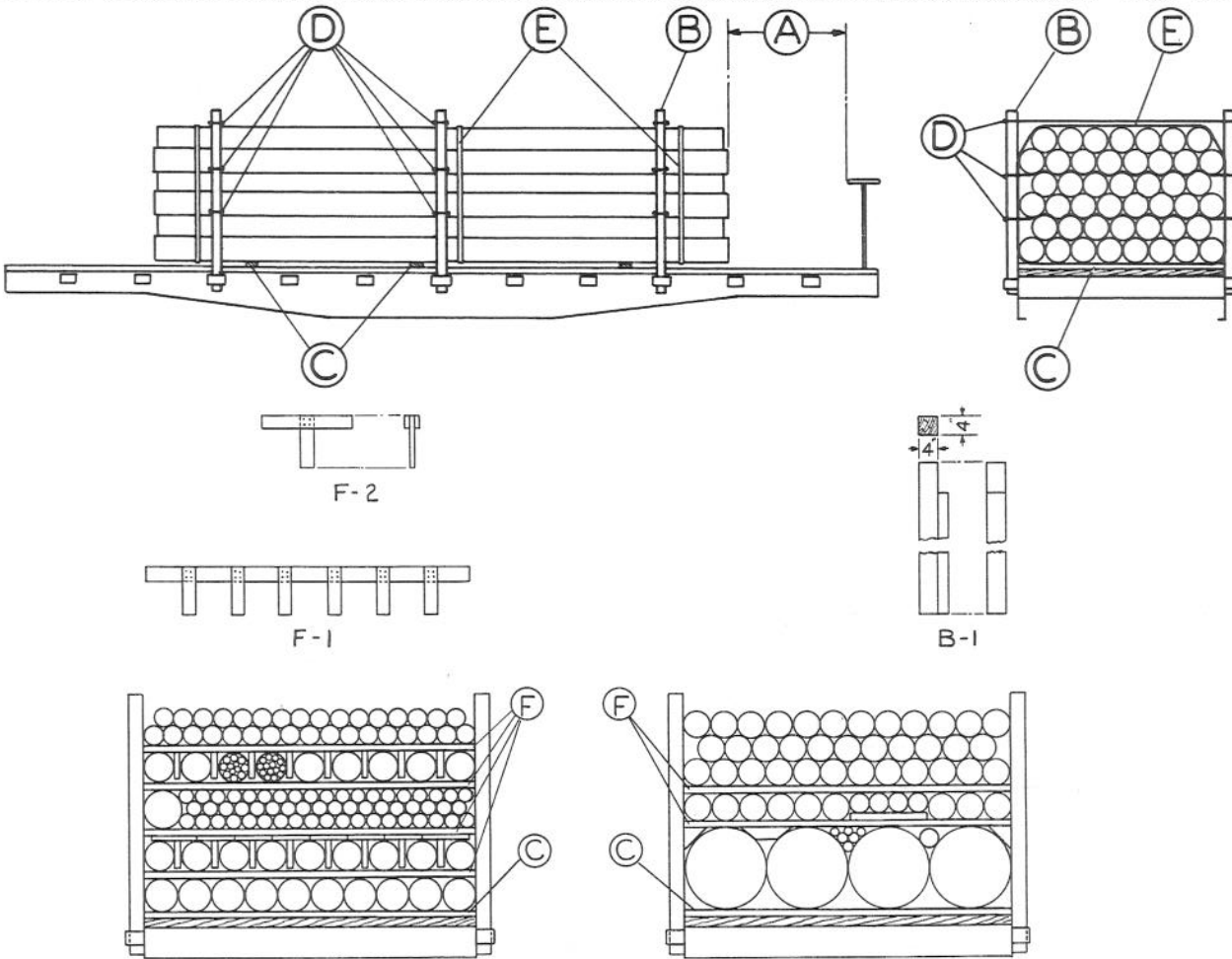

SKETCH. No. 1

SKETCH. No. 2

Item	No. of Pcs.	Description
A		Brake wheel clearance. See Fig. 2.
B	Pile 4 ft. high or less: 3 pr. per pile 34 ft. long or less; 4 pr. per pile over 34 ft. long. Pile over 4 ft. high: 4 pr. per pile 34 ft. long or less; 5 pr. per pile over 34 ft. long.	Stakes, hardwood, spaced as equally as possible. Fill space between pipe and stakes by nailing suitable fillers to inside face of stakes, per Sketch B-1.
C	3 per pile	4 in. wide, length equal to width of car, high enough to protect bands, suitably spaced.
D	Ea. Pr. Items "B", as required	6 strands, No. 11 ga. wire. Space lower wire not more than 20 in. from floor and intermediate wires not more than 20 in. apart, except for pipe over 20 in. dia., use wire or band between each successive layer. Place wire or band across top of pile.
E	1 ea. pr. Item "B"	2 in. x .050 in. bands, suitably spaced.
F	3 between one or more successive layers. Use only when necessary for separation of pipe.	2 in. x 4 in., hardwood, length equal to width of load, not to extend beyond inside face of stakes, equally spaced. For pipe 10 in. or more in dia., nail a 2 in. x 4 in. block, length to suit, located midway between both ends, with three 20-D nails. On pipe less than 10 in. dia., size of block to be as large as possible, located in same manner. Place one pipe directly above the one below, if possible, otherwise use supports underneath Items "F", per Sketch 2, for spaces over 10 in. between pipe and over 4 in. between pipe and inside of Items "B", measured crosswise. Suitable vertical separators, per Sketch F-1, nailed to Item "F", or "T" shaped separators, per Sketch F-2, may be used as per Sketch 1.

Ends of pipe must not be less than 18 in. from ends of car.

Couplings must be staggered and must not rest on each other.

Wire, flat metal strips or heavy paper may be placed between pipe where separations are required for identification purposes.

Tubular steel poles, tapered or made of two or more sections of different diameters, must be loaded with the large and small ends alternated in each layer. Use suitable fillers when necessary to equalize load.

Pipe 12 ft. long or less must not be loaded on flat cars. Small diameter pipe must not be loaded inside larger diameter pipe.

See General Rules 4, 5, 9, 10, 14 and 15 for further details.

Sec. 2—Fig. 122

WROUGHT IRON AND STEEL PIPE 26 INCHES OR LESS IN DIAMETER, WITH WIRE—GONDOLA CARS

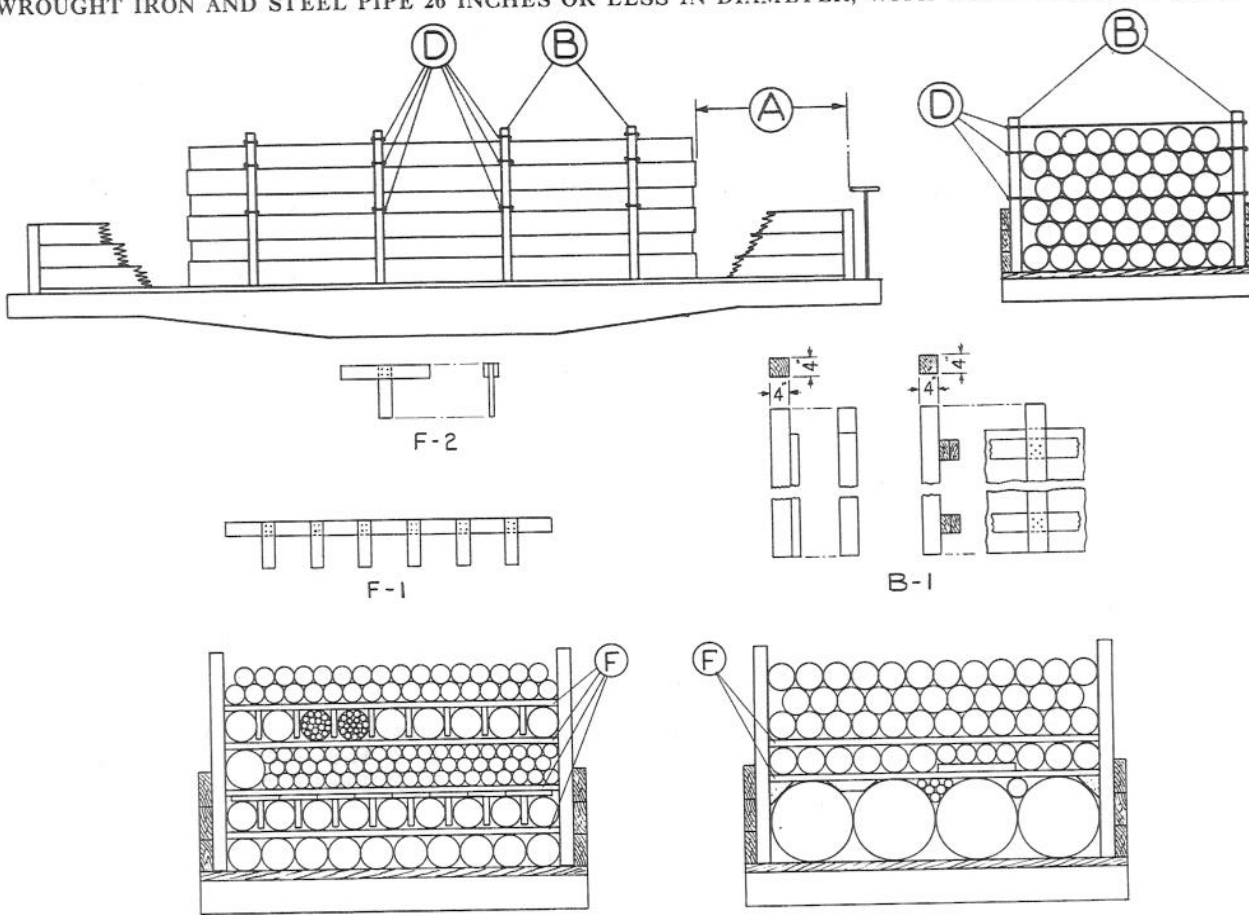

SKETCH No. 1

SKETCH No. 2

Item	No. of Pcs.	Description
A		Brake wheel clearance. See Fig. 2.
B	Pile 3 ft. high or less above car sides: 4 pr. per pile 25 ft. long or less; 5 pr. per pile over 25 ft. to 34 ft. long, inclusive; 6 pr. per pile over 34 ft. long. Pile over 3 ft. high above car sides: 5 pr. per pile 25 ft. long or less; 6 pr. per pile over 25 ft. long.	Stakes, hardwood, equally spaced. Fill space between stakes and car sides by nailing fillers to stakes, per Sketch B-1.
C		VACANT.
D	Ea. Pr. Items "B", as required.	6 strands, No. 11 ga. wire. Place lower wire underneath layer, extending more than 1/2 its dia. above top of car sides, and on top of layer if less than 1/2 of its dia. is above top of car sides. Place top wire across top of pile. Place intermediate wire not more than 18 in. apart, except on pipe 18 in. or more in dia., use wire between each successive layer of pipe. On loads 1 ft. 6 in. high or less above car sides, space top and bottom wires not less than 1 ft. 6 in. apart. Space wire as near same distance apart as possible.
E		VACANT
F	3 between one or more successive layers. Use only when necessary for separation of pipe.	2 in. x 4 in., hardwood, length equal to width of load, not to extend beyond inside face of stakes, equally spaced. For pipe 10 in. or more in dia., nail a 2 in. x 4 in. block, length to suit, located midway between both ends, with three 20-D nails. On pipe less than 10 in. dia., size of block to be as large as possible, located in same manner. Not required for Items "F" located below top of car sides or when separators (F-1) are used. Place one pipe directly above the one below, if possible, otherwise use supports underneath Items "F", per Sketch 2, for spaces over 10 in. between pipe and over 4 in. between pipe and inside of Items "B", measured crosswise. Suitable vertical separators, per Sketch F-1, nailed to Item "F", or "T" shaped separators per Sketch F-2, may be used as per Sketch 1.

Couplings must be staggered and must not rest on each other.
 Pipe 12 ft. long or less must be loaded below top of car sides. Small diameter pipe must not be loaded inside larger diameter pipe, except when loaded below top of car sides.
 Wire, flat metal strips or heavy paper may be placed between pipe where separations are required for identification purposes.
 Tubular steel poles, tapered or made of two or more sections of different diameters, must be loaded with the large and small ends alternated in each layer. Use suitable fillers when necessary to equalize load.
 See General Rules 4, 5, 9, 10, 14 and 15 for further details.

Sec. 2—Fig. 123

WROUGHT IRON AND STEEL PIPE, 26 IN. OR LESS IN DIAMETER, WITH NO. 8 GAGE HIGH TENSION WIRE—
GONDOLA CARS

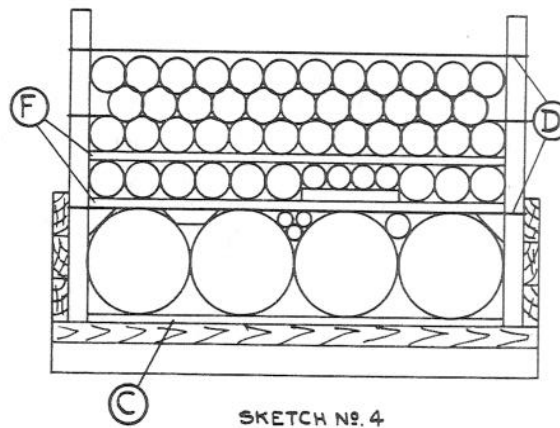
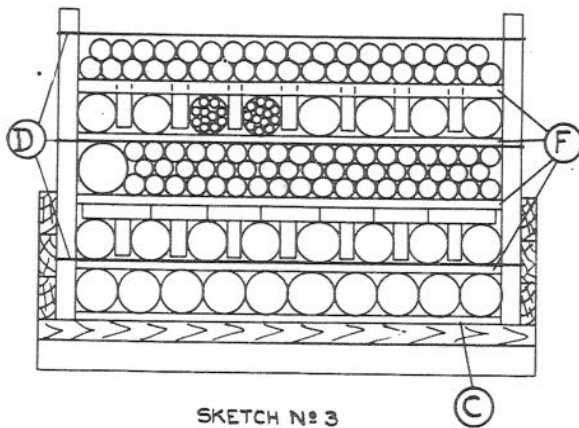
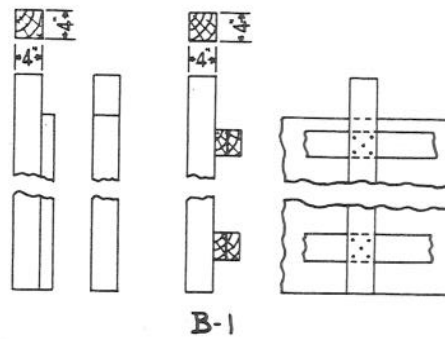
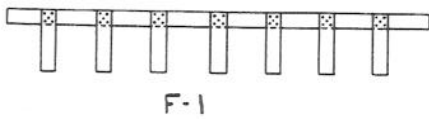
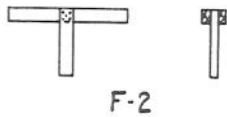
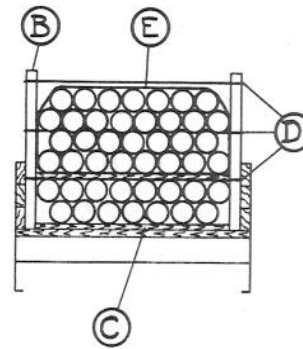
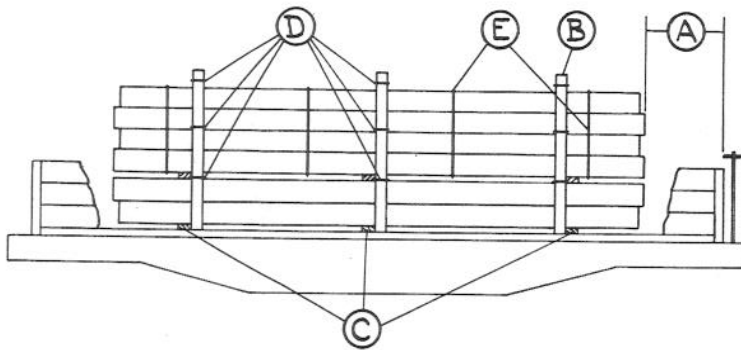
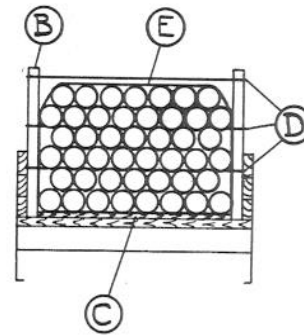
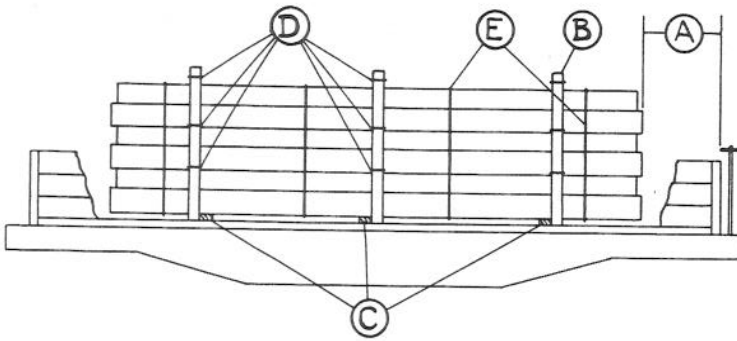

Sec. 2—Fig. 123

WROUGHT IRON AND STEEL PIPE, 26 IN. OR LESS IN DIAMETER, WITH NO. 8 GAGE HIGH TENSION WIRE—
GONDOLA CARS

Item	No. of Pcs.	Description
A		Brake wheel clearance. See Fig. 2.
B	Pile 3 ft. 6 in. high or less above car sides, 3 pr. per pile. Pile over 3 ft. 6 in. high above car sides, 4 pr. per pile 34 ft. long or less, 5 pr. per pile over 34 ft. long.	Stakes, hardwood, equally spaced. Fill space between stakes and car sides by nailing fillers to stakes per Sketch B-1.
C	3 per pile	4 in. wide, length equal to width of car, high enough to protect wires, suitably spaced.
D	Pile 3 ft. 6 in. high or less above car sides, 34 ft. long or less, 2 ea. pr. Items "B"; pile over 34 ft., 3 ea. pr. Items "B". Pile over 3 ft. 6 in. high above car sides, 3 ea. pr. Items "B"	2 strands. Place lower wire about midway between top of car floor and top of car sides, when practicable. On large diameter pipe, place across top of bottom row. Place intermediate wire about midway between top wire and top of car sides, when practicable. Place top wire across top of pile. High tension bands must not be substituted.
E	Pile 3 ft. 6 in. high or less above car sides, 34 ft. long or less, 4 per pile; over 34 ft. long, 5 per pile. Pile over 3 ft. 6 in. high above car sides, 34 ft. long or less, 5 per pile; over 34 ft. long, 6 per pile	If desired, these wires may pass underneath pipe below top of car sides; provided the pipe so tied forms a unit not less than 3 ft. 6 in. high, per Sketch 2. In such cases place three 1 in. x 4 in. strips between layers of pipe to protect wires. High tension bands must not be substituted.
F	3 between one or more successive layers. Use only when necessary for separation of pipe.	2 in. x 4 in., hardwood, length equal to width of load, not to extend beyond inside face of stakes, equally spaced. For pipe 10 in. or more in dia., nail a 2 in. x 4 in. block, length to suit, located midway between both ends, with three 20-D nails. On pipe less than 10 in. dia., size of block to be as large as possible, located in same manner. Not required for Items "F" located below top of car sides or when separators (F-1) are used. Place one pipe directly above the one below, if possible, otherwise use supports underneath Items "F", per Sketch 4, for spaces over 10 in. between pipe and over 4 in. between pipe and inside of Items "B", measured crosswise. Suitable vertical separators, per Sketch F-1, nailed to Item "F", or "T" shaped separators, per Sketch F-2, may be used as per Sketch 3.

Couplings must be staggered and must not rest on each other.

Fifth pair of Items "B" may be omitted by adding one additional wire, Item "E", for loads over 3 ft. 6 in. high above car side and over 34 ft. in length.

Pipe 8 ft. long or less must be loaded below top of car sides. Small diameter pipe must not be loaded inside larger diameter pipe, except when loaded below top of car sides.

Wire, flat metal strips or heavy paper may be placed between pipe where separations are required for identification purposes.

Tubular steel poles, tapered or made of two or more sections of different diameters, must be loaded with the large and small ends alternated in each layer. Use suitable fillers when necessary to equalize load.

See General Rules 4, 5, 9, 10, 14 and 15 for further details.

WROUGHT IRON AND STEEL PIPE, 26 IN. OR LESS IN DIAMETER, WITH HIGH TENSION BANDS—GONDOLA CARS

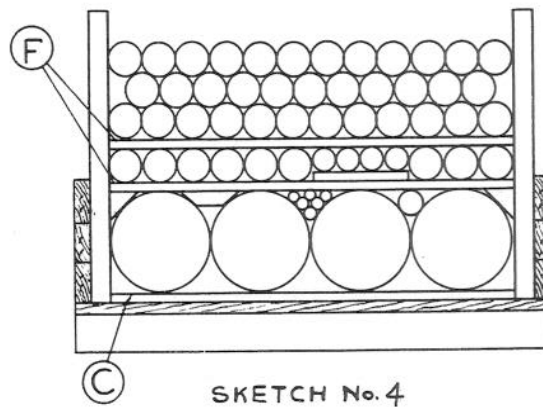
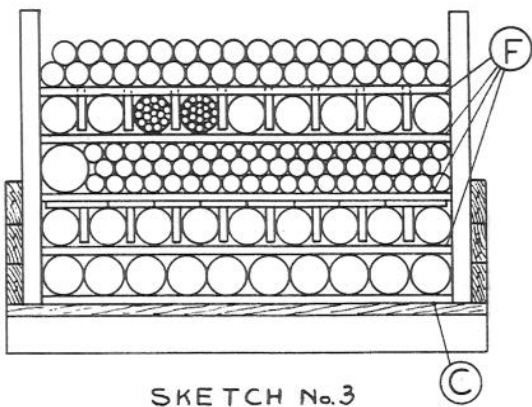
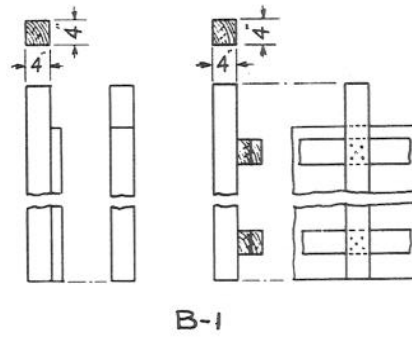
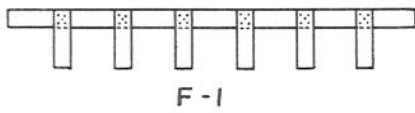
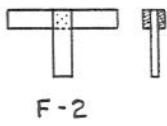
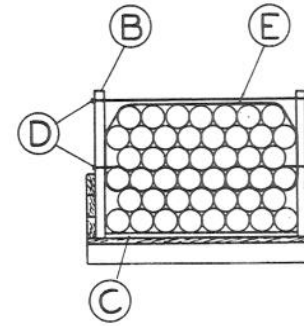
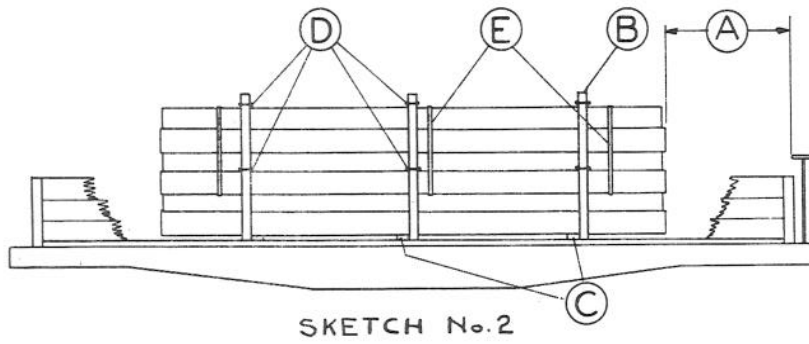
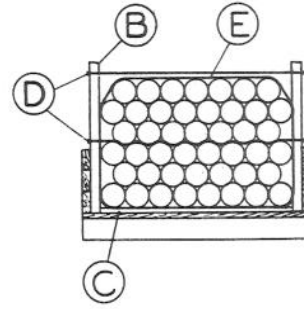
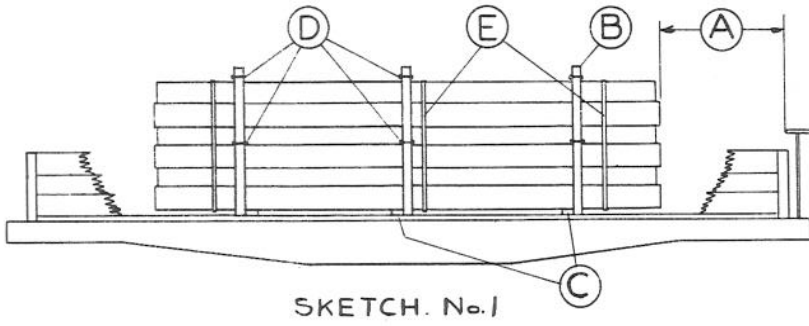

Sec. 2—Fig. 124

WROUGHT IRON AND STEEL PIPE, 26 IN. OR LESS IN DIAMETER, WITH HIGH TENSION BANDS—GONDOLA CARS

Item	No. of Pcs.	Description
A		Brake wheel clearance. See Fig. 2.
B	Pile 3 ft. 6 in. high or less above car sides, per 3 pr. per pile. Pile over 3 ft. 6 in. high above car sides, 4 pr. per pile.	Stakes, hardwood, equally spaced. Fill space between stakes and car sides by nailing fillers to stakes, per Sketch B-1.
C	3 per pile.	4 in. wide, length equal to width of car, high enough to protect bands, suitably spaced.
D	2 ea. pr. Items "B"	1 Strand, $1\frac{1}{4}$ in. x .035 in. band, or 6 strands, No. 11 ga. wire. Locate one close to top of car sides, and the other across top of pile. On loads 1 ft. 6 in. high or less above car sides, space top and bottom bands or wires not less than 1 ft. 6 in. apart.
E	Pile 3 ft. 6 in. high or less above car sides: 3 per pile 34 ft. long or less; 4 per pile over 34 ft. long. Pile over 3 ft. 6 in. high above car sides: 4 per pile 34 ft. long or less; 6 per pile over 34 ft. long (5 only required when 2 in. x .050 in. bands are used.)	$1\frac{1}{4}$ in. x .035 in., or 2 in. x .050 in. bands, suitably spaced. For piles exceeding 7 ft. 6 in. in height, tie upper portion into a unit including all pipe extending wholly or partially above top or car sides, forming a unit not less than 3 ft. 6 in. high, per Sketch 2. For pile 7 ft. 6 in. high or less, pass bands around entire load. If desired, these bands may pass underneath pipe below top of car sides provided the pipe, so tied, forms a unit not less than 3 ft. 6 in. high, per Sketch 2.
F	3 between one or more successive layers. Use only when necessary for separation of pipe.	2 in. x 4 in., hardwood, length equal to width of load, not to extend beyond inside face of stakes, equally spaced. For pipe 10 in. or more in dia., nail a 2 in. x 4 in. block, length to suit, located midway between both ends, with three 20-D nails. On pipe less than 10 in. dia., size of block to be as large as possible, located in same manner. Not required for Items "F" located below top of car sides or when separators (F-1) are used. Place one pipe directly above the one below, if possible, otherwise use supports underneath Items "F", per Sketch 4, for spaces over 10 in. between pipe and over 4 in. between pipe and inside of Items "B", measured crosswise. Suitable vertical separators, per Sketch F-1, nailed to Items "F", or "T" shaped separators, per Sketch F-2, may be used as per Sketch 3.

Couplings must be staggered and must not rest on each other.

Pipe 8 ft. long or less must be loaded below top of car sides. Small diameter pipe must not be loaded inside larger diameter pipe, except when loaded below top of car sides.

Flat metal strips or heavy paper may be placed between pipe where separations are required for identification purposes.

Tubular steel poles, tapered or made of two or more sections of different diameters, must be loaded with the large and small ends alternated in each layer. Use suitable fillers when necessary to equalize load.

See General Rules 4, 5, 9, 10, 14 and 15 for further details.

WROUGHT IRON AND STEEL PIPE, 26 INCHES OR LESS IN DIAMETER, IN PYRAMIDAL FORM, WITH NO. 8 GAGE HIGH TENSION WIRES—GONDOLA CARS

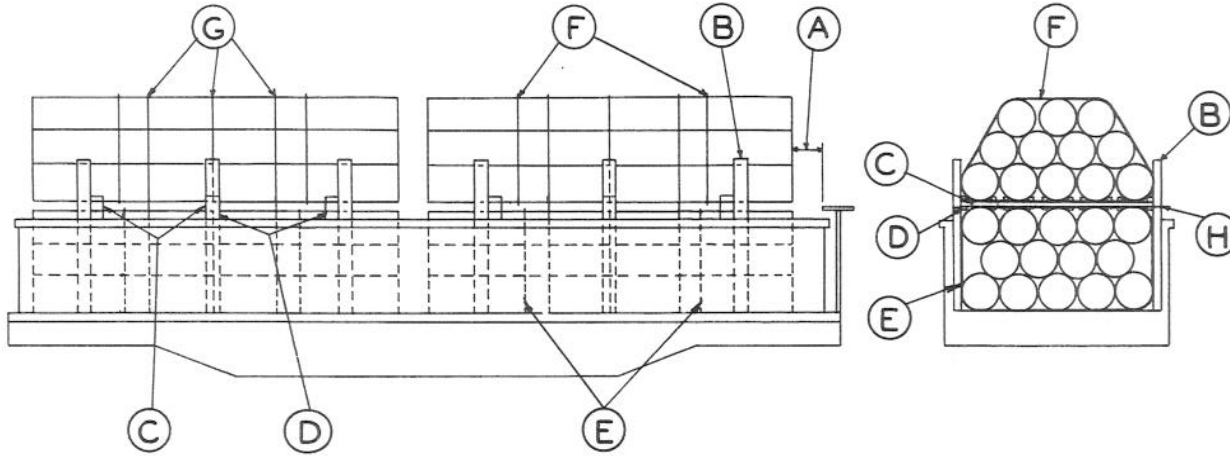

Item	No. of Pcs.	Description
A		Brake wheel clearance. See Fig. 2.
B	Pile 40 ft. long or less, 3 pr. per pile. For ea. 10 ft. or less over 40 ft. long, 1 additional pr. per pile.	Stakes, hardwood, extending to top of pipe forming the base layer of pyramid.
C	3 per pile.	2 in. x 4 in., length equal to width of load, equally spaced between base layer of pyramid and top layer of lower unit. On cars with sides 54 in. high or over, locate on layer even with or extending partially above top of car sides. On cars with sides less than 54 in. high, locate not to exceed 4 ft. 6 in. from floor. If lower unit consists of mixed diameter pipe, level off top layer to provide uniform bearing, full length of Items "C".
D	As required.	3 in. x 4 in. x 4 in., nailed on top of Item "C", against each side of each pipe in the base layer of pyramid, and on bottom sides at each end bearing against outside pipe of the layer below.
E	Pile 40 ft. long or less, 2 per pile. For ea. 10 ft. or less over 40 ft. long, 1 additional per pile.	1 strand, around pipe below Items "C". Not required when layer of pipe directly below Items "C" is at least one-half its diameter below top of car sides. High tension bands must not be substituted.
F	Pile 40 ft. long or less, 2 per pile. For ea. 10 ft. or less over 40 ft. long, 1 additional per pile.	1 strand, around pyramided portion, equally spaced. High tension bands must not be substituted.
G	3 per pile.	1 strand, around entire load. Locate one about 4 ft. from each end and one at center. High tension bands must not be substituted.
H	1 ea. pr. Items "B".	2 strands. High tension bands must not be substituted.

When height of load does not exceed 30 inches above top of car sides, and more than one-half the diameter of pipe in base layer of pyramid is below top of car sides, Items "B", "C", "D", "E", "G" and "H" may be omitted, provided Items "F" are 15 in. or more below top of car sides. When so loaded, use six Items "F" for pile 24 ft. long or less, seven for piles over 24 ft. long to and including 40 ft. long, and eight for pile over 40 ft. long. End wires must be located about 2 ft. from each end of pile, and all wires must be about equally spaced.

For pipe 18 in. to 26 in. in diameter, inclusive, Items "B", "C", "D", "E", "F" and "H" may be omitted when eight equally spaced wires, Items "G", encircle the entire pile and when at least one-half the diameter of pipe in base layer of pyramid is below top of car sides.

Couplings must be staggered and must not rest on each other.

Pipe 8 ft. long or less must be loaded below top of car sides. Small diameter pipe must not be loaded inside larger diameter pipe, except when loaded below top of car sides.

Wire, flat metal strips or heavy paper may be placed between pipe where separators are required for identification purposes.

See General Rules 4, 5, 9, 10, 14 and 15 for further details.

Sec. 2—Fig. 126

WROUGHT IRON AND STEEL PIPE, 26 IN. OR LESS IN DIAMETER, IN PYRAMIDAL FORM WITH
HIGH TENSION BANDS—GONDOLA CARS

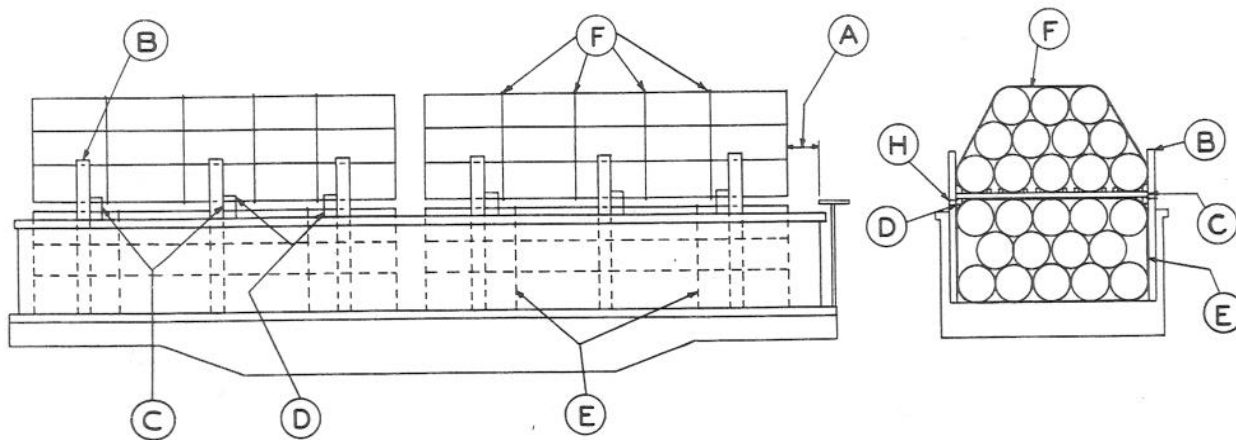

Item	No. of Pcs.	Description
A		Brake wheel clearance. See Fig. 2.
B	Pile 40 ft. long or less, 3 pr. per pile; for ea. 10 ft. or less over 40 ft. long, 1 additional pr. per pile.	Stakes, hardwood, extending to top of pipe forming the base layer of pyramid.
C	1 ea. pr. Items "B"	2 in. x 4 in., length equal to width of load, equally spaced between base layer of pyramid and top layer of lower unit. On cars with sides 54 in. high or over, locate on layer even with or extending partially above top of car sides. On cars with sides less than 54 in. high, locate not to exceed 4 ft. 6 in. from floor. If lower unit consists of mixed diameter pipe, level off top layer to provide uniform bearing, full length of Items "C".
D	As required.	3 in. x 4 in. x 4 in., nailed on top of Items "C", against each side of each pipe in the base layer of pyramid, and on bottom sides at each end bearing against outside pipe of the layer below.
E	Pile 40 ft. long or less, 2 per pile; for ea. 10 ft. or less over 40 ft. long, 1 additional per pile.	1 1/2 in. x .035 in. bands, around pipe below Items "C". Not required when layer of pipe directly below Items "C", is at least one-half its diameter below top of car sides.
F	Pile 40 ft. long or less, 4 per pile; for ea. 10 ft. or less over 40 ft. long, 1 additional per pile.	1 1/2 in. x .035 in. bands, around pyramided portion, equally spaced.
G		VACANT.
H	1 ea. pr. Items "B"	1 1/2 in. x .035 in. bands. Locate at Items "C".

When height of load does not exceed 30 in. above top of car sides and 1/2 dia. of pipe in base layer of pyramid is below top of car sides, Items "B", "C", "D", "E" and "H" may be omitted, provided Item "F" is 15 in. or more below top of car sides.

For pipe from 16 in. to 26 in. in diameter, inclusive, Items "B", "C", "D", "E" and "H" may be omitted when six equally spaced bands, Items "F", encircle the entire pile, and when at least one-half the diameter of pipe in base layer of pyramid is below top of car sides.

Couplings must be staggered and must not rest on each other.

Pipe 8 ft. long or less must be loaded below top of car sides. Small diameter pipe must not be loaded inside larger diameter pipe, except when loaded below top of car sides.

Wire, flat metal strips or heavy paper may be placed between pipe where separations are required for identification purposes.

When bottom row does not fill width of car, chock blocks must be placed between pipe so as to bring outside pipe of base layer flush with side stakes.

See General Rules 4, 5, 7, 9, 10, 14 and 15 for further details.

COATED WROUGHT IRON AND STEEL PIPE 22 INCHES AND OVER IN DIAMETER, 30 FT. OR OVER, IN LENGTH, ON SKIDS, WITH 2 IN. X .050 IN. HIGH TENSION BANDS—ENDS OF LOAD MUST NOT BE LESS THAN 2 FT. 6 IN. FROM ITEM "K"—GONDOLA CARS

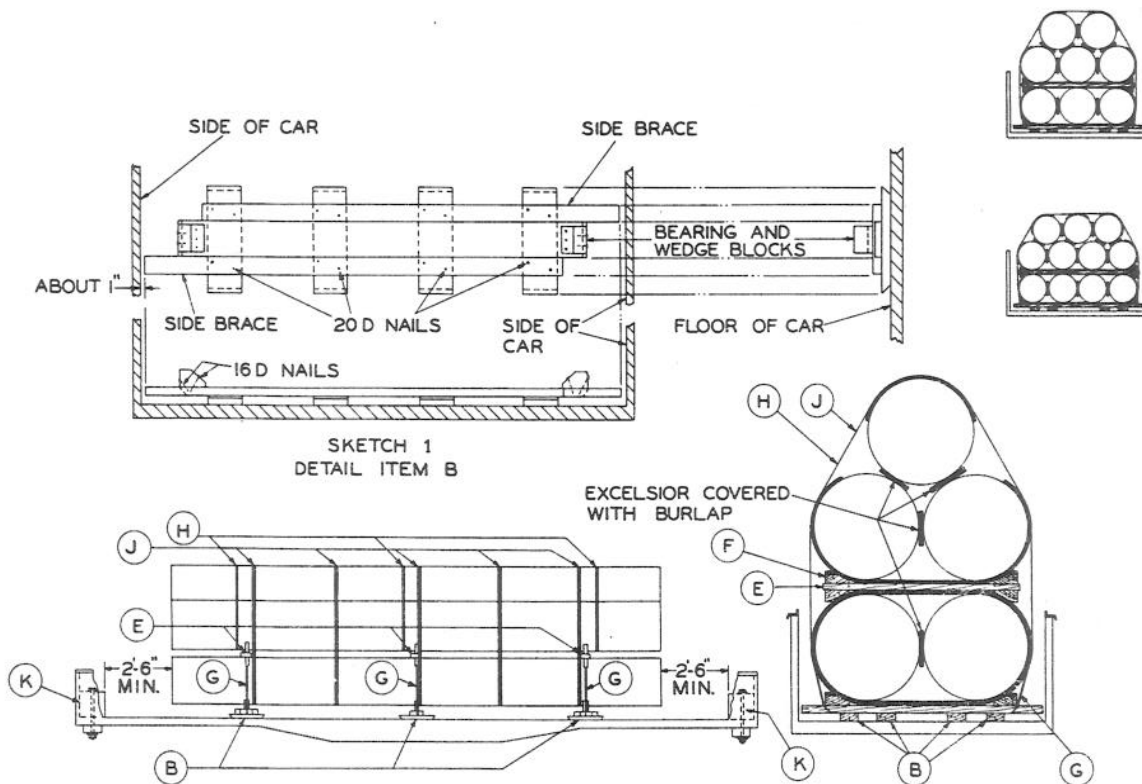

Item	No. of Pcs.	Description
A		Brake wheel clearance. See Fig. 2.
B	3 per pile.	Bearing skids, each comprising one 2 in. x 8 in., hardwood plank, two 4 in. x 6 in., hardwood wedge blocks, four 2 in. x 8 in. x 24 in., hardwood skid blocks and two 2 in. x 4 in., hardwood side braces. See Sketch 1.
C		VACANT.
D		VACANT.
E	3 per pile between first and second layer.	2 in. x 8 in., hardwood, long enough to apply Items "F" but short enough to clear bands. Locate directly above Items "B".
F	4 ea. Item "E".	4 in. x 6 in., hardwood, wedge-shaped blocks. Nail to top and bottom of Items "E" with five 16-D nails in each, three in tapered face and two in outside face.
G	3 per pile.	Bands, encircling bottom row and Item "B".
H	3 per pile.	Bands, encircling top portion of pile above bottom row.
J	5 per pile.	Bands, encircling entire pile.
K	1 ea. end of load.	6 in. x 6 in., hardwood, length equal to inside width of car. Locate tight against end of car and secure each to floor with two $\frac{1}{8}$ in. dia. bolts passed through Item "K", floor and 4 in. x 4 in. x 18 in., hardwood, or $\frac{1}{2}$ in. x 4 in. x 18 in. plate under floor.

When loaded, pile should be located equally distant from each end of car.

Pipe must be separated and protected on bearing pieces and under bands by excelsior covered with burlap or similar padding.

See General Rules 4, 5, 9, 10, 14 and 15 for further details.

THIS PAGE WAS LEFT BLANK INTENTIONALLY

Sec. 2—Fig. 128

WROUGHT IRON AND STEEL PIPE, 24 INCHES TO 31 INCHES, INCLUSIVE, IN DIAMETER, IN PYRAMIDAL FORM,
 WITH 2 IN. X .050 IN. HIGH TENSION BANDS—FLAT CARS
 17 PIECES PER CAR, LESS THAN $\frac{3}{8}$ IN. THICK
 15 PIECES PER CAR, $\frac{3}{8}$ IN. TO $\frac{1}{2}$ IN. THICK
 12 PIECES PER CAR, $\frac{1}{2}$ IN. THICK AND OVER

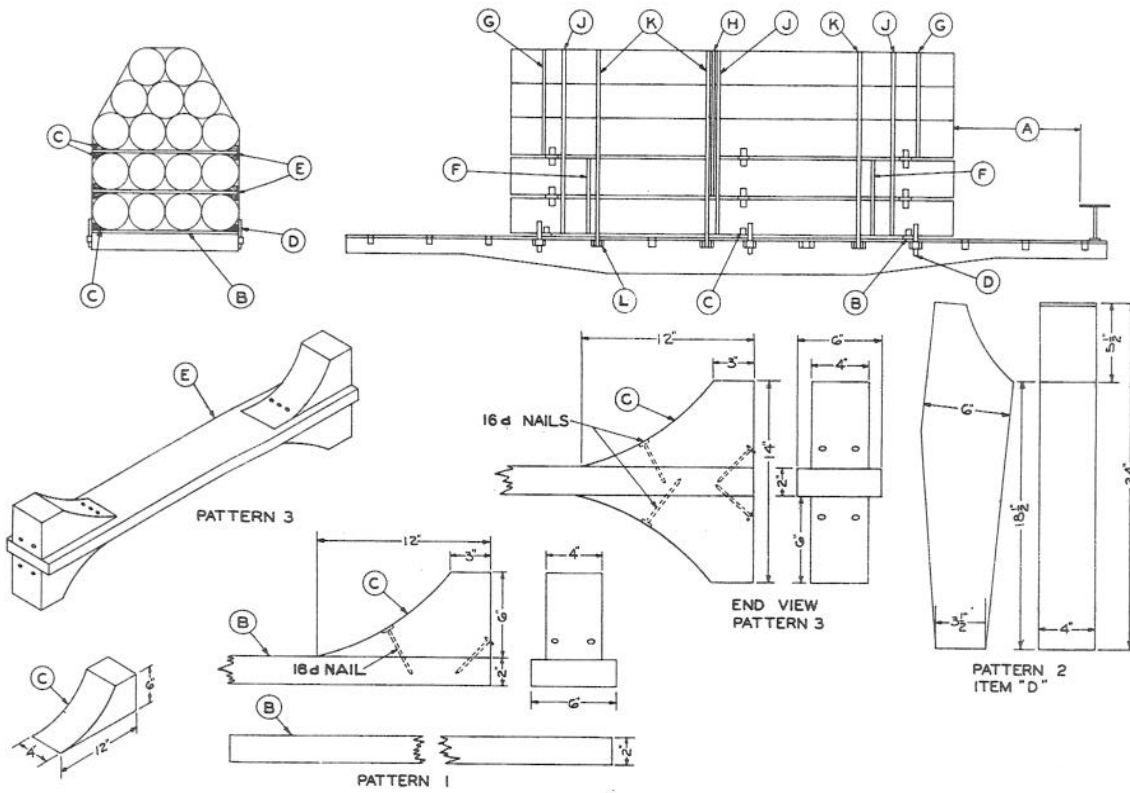

Sec. 2—Fig. 128

WROUGHT IRON AND STEEL PIPE, 24 INCHES TO 31 INCHES, INCLUSIVE, IN DIAMETER, IN PYRAMIDAL FORM,
 WITH 2 IN. X .050 IN. HIGH TENSION BANDS—FLAT CARS
 17 PIECES PER CAR, LESS THAN $\frac{3}{8}$ IN. THICK
 15 PIECES PER CAR, $\frac{3}{8}$ IN. TO $\frac{1}{2}$ IN. THICK
 12 PIECES PER CAR, $\frac{1}{2}$ IN. THICK AND OVER

Item	No. of Pcs.	Description
A		Brake wheel clearance. See Fig. 2.
B	Pile 31 ft. long or less, 3 per pile. Add one for each additional 10 ft. or less in length.	2 in. x 6 in., wood, length equal to width of car, suitably spaced and nailed to car floor with six 16-D nails.
C	2 ea. Item "B". Also used with Item "E" as required.	4 in. x 6 in. x 12 in., wood chock blocks, cut to fit contour of pipe. Locate against pipe and nail to Item "B" with five 16-D nails, 3 through contour surface and Item "B" and 2 through vertical surface and Item "B". Pattern 1.
D	1 pr. ea. Item "B".	Stakes 4 in. x 6 in. x 24 in., hardwood, Pattern 2. Inside face cut to fit contour of pipe and suitably spaced. When width of load does not permit location of contoured side stake against outside surface of pipe in bottom layer, suitable wood filler must be used between Items "D" and load.
E	Pile 31 ft. long or less, 3 between first and second layer, and 3 between second and third layer. Add one between first and second layer and one between second and third layer for each additional 10 ft. or less in length.	2 in. x 6 in., wood, length equal to width of load, with four 4 in. x 6 in. x 12 in. wood chock blocks (Item "C"). Locate against pipe and nail to Item "E" with five 16-D nails, three through contour surface and Item "E", and two through vertical surface and Item "E". Pattern 3.
F	Pile 31 ft. long or less, 2 per pile. Add one for each additional 10 ft. or less in length.	2 in. x .050 in. bands, suitably spaced, encircling the two bottom layers.
G	Pile 31 ft. long or less, 2 per pile. Add one for each additional 10 ft. or less in length.	2 in. x .050 in. bands, suitably spaced, encircling all layers above the two bottom layers.
H	Pile 31 ft. long or less, 1 per pile. Add one for each additional 10 ft. or less in length.	2 in. x .050 in. band suitably spaced, encircling entire pile above bottom layer.
J	Pile 31 ft. long or less, 3 per pile. Add one for each additional 10 ft. or less in length.	2 in. x .050 in. bands, suitably spaced, encircling entire pile.
K	Pile 31 ft. long or less, 3 per pile. Add one for each additional 10 ft. or less in length.	2 in. x .050 in. bands, suitably spaced, secured to opposite stake pockets.
L	2 ea. Item "K".	Metal filler 4 in. wide and of sufficient thickness to maintain $\frac{1}{2}$ in. radius and secured to prevent displacement must be used to protect bands at all stake pockets.

Pipe must be loaded centrally on car.

See General Rules 4, 5, 9, 10, 14 and 15 for further details.

Sec. 2—Fig. 128

NO. 10 STEEL PIPE, 24 INCHES TO 31 INCHES, INCLUSIVE, IN DIAMETER, IN PYRAMIDAL FORM,
 WITH 2 IN. X .050 IN. HIGH TENSION BANDS—FLAT CARS
 17 PIECES PER CAR, LESS THAN $\frac{3}{8}$ IN. THICK
 15 PIECES PER CAR, $\frac{3}{8}$ IN. TO $\frac{1}{2}$ IN. THICK
 12 PIECES PER CAR, $\frac{1}{2}$ IN. THICK AND OVER

AM L

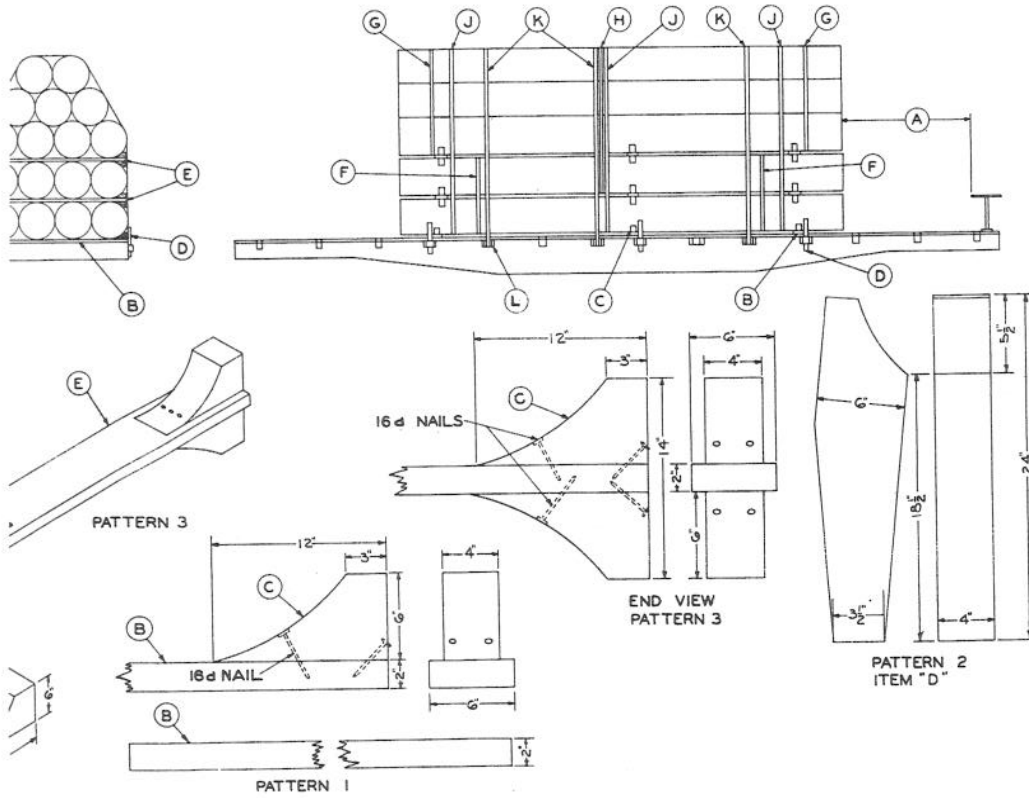

r
f

Sec. 2—Fig. 130

WROUGHT IRON AND STEEL PIPE, OVER 26 IN. IN DIAMETER, 8 FT. TO LESS THAN 12 FT. IN LENGTH, WITH 2 IN. X .050 IN. HIGH TENSION BANDS—GONDOLA CARS

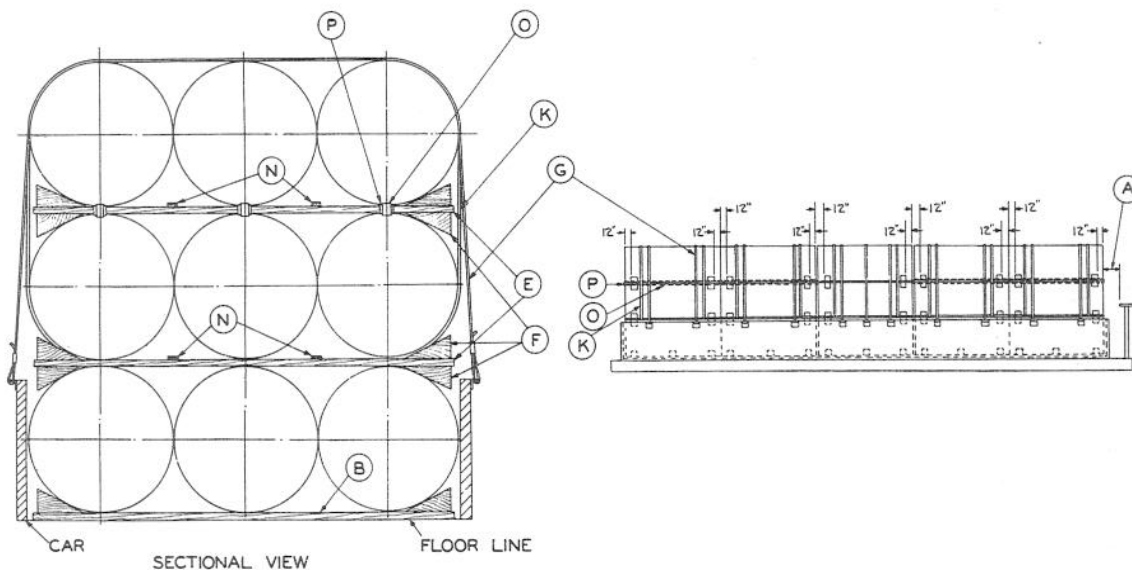

Item	No. of Pcs.	Description
A		Brake wheel clearance. See Fig. 2.
B	3 per pile.	2 in. x 4 in., hardwood, length equal to width of car, suitably spaced. Locate end pieces approximately 12 in. from each end of pile and third piece at center.
C		VACANT.
D		VACANT.
E	2 per pile between ea. successive layer.	2 in. x 6 in., hardwood, long enough to apply Items "F" but short enough to clear bands. Locate approximately 12 in. from each end of pile. Not required beneath top layer when top layer is nested.
F	2 ea. Item "B". 4 ea. Item "E".	4 in. x 6 in., hardwood, wedge shaped, nailed to top of Items "B" and to top and bottom of Items "E" with five 16-D nails in each, three in tapered face and two in outside face.
G	2 on ea. of the 2 outer piles ea. end. 3 on intermediate piles.	Bands. Pass over top of load and attach to opposite car sides.
H		VACANT.
J	2 ea. Item "G".	4 in. wide, 1/2 in. radius, metal filler of suitable design and strong enough to maintain this radius. Required only when necessary to protect bands.
K	2 per pile.	Bands encircling top portion of pile above bottom row. Locate approximately 12 in. from outside Items "G".
L		VACANT.
M		VACANT.
N	As required.	1 in. x 2 in., hardwood, longitudinal strips, long enough to tie Items "E" together. Locate as shown and nail to Items "E" with two 8-D nails at each location.
O	As required on ea. of the 2 outer piles on ea. end, above bottom row.	Bands, longitudinally, tying the first two piles together, as shown.
P	2 ea. Item "O".	Protection clips, 20 gage, 4 in. wide, applied so as to prevent displacement.

When more than one-half the diameter of top layer of pipe is below top of car sides, Items "G", are not required. Longitudinal welds on pipe must not contact bands. Pipe less than 8 ft. long must be loaded below top of car sides. See General Rules 4, 5, 9, 10, 14 and 15 for further details.

Sec. 2—Fig. 131

WROUGHT IRON AND STEEL PIPE, OVER 26 INCHES IN DIAMETER, 63 FT. LONG OR LESS, WITH HIGH TENSION BANDS OR WIRES—GONDOLA CARS

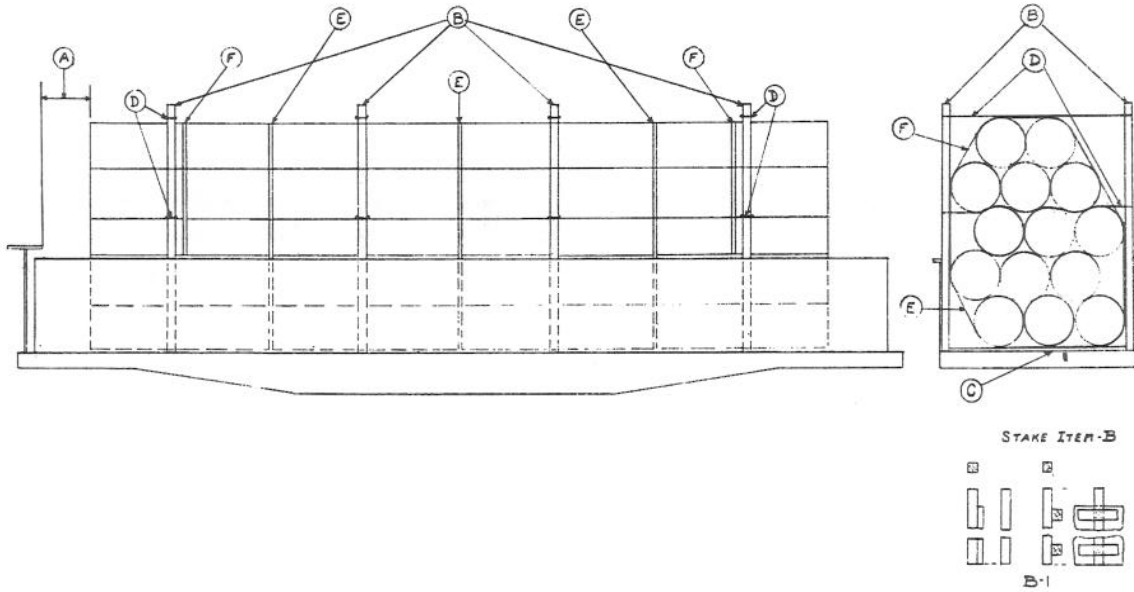

Item	No. of Pcs.	Description
A		Brake wheel clearance. See Fig. 2.
B	4 pr. per pile 41 ft. long or less. 5 pr. per pile over 41 ft. long.	Stakes, hardwood, equally spaced, extending above load to permit application of Item "D". Fill space between stakes and car sides by nailing fillers to stakes, per Sketch B-1.
C	1 ea. pr. Items "B".	2 in. x 4 in., length to suit. Locate between Items "B".
D	2 ea. pr. Items "B".	8 strands No. 11 gage wire. Locate at top of load and one midway between top of car side and top of load. Substitute, if desired, at each location, one 1¼ in. x .035 in. high tension band.
E	3 per pile 41 ft. long or less. 4 per pile over 41 ft. long.	2 in. x .050 in. high tension bands encircling entire pile, equally spaced over length of pile.
F	2 per pile.	2 in. x .050 in. high tension bands, encircling all pipe extending wholly or partially above car side. Locate near end Items "B".

Pile must be located centrally on car.

See General Rules 4, 5, 9, 10, 14 and 15 for further details.

WROUGHT IRON AND STEEL PIPE, 30 INCHES IN DIAMETER 41 FT. LONG OR LESS, 13 PIECES PER CAR, WITH HIGH TENSION BANDS—GONDOLA CARS

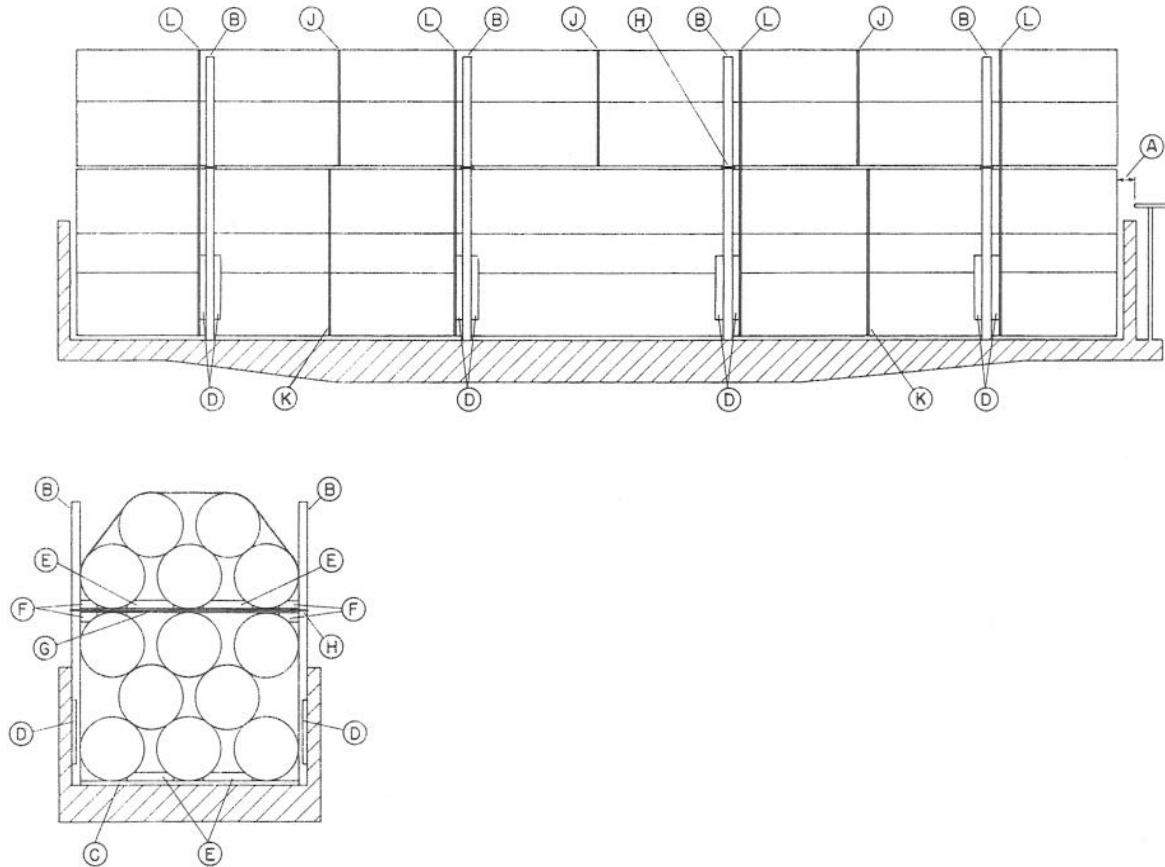

Item	No. of Pcs.	Description
A		Brake wheel clearance. See Fig. 2.
B	4 pr. per pile.	Stakes, hardwood, 4 in. x 4 in. x 9 ft.
C	1 ea. pr. Items "B".	2 in. x 4 in. length to suit, floor bearing pieces. Locate between Items "B".
D	2 ea. Item "B".	2 in. x 4 in. x 30 in., softwood, stake clamp blocks. Locate as shown front and back of Items "B". Secure to car side with 20-D nails. Use optional.
E	4 ea. pr. Items "B".	4 in. x 4 in. x 24 in., hardwood, chock blocks shaped and located as shown. Nail to Items "C" and "G" with four 30-D nails.
F	4 ea. pr. Items "B".	4 in. x 4 in. x 8½ in., hardwood, chock blocks, shaped and located as shown. Nail to top and bottom each end of Items "G" with four 30-D nails.
G	1 ea. pr. Items "B".	2 in. x 4 in. wood, separator, length to suit. Locate as shown between Items "B".
H	1 ea. pr. Items "B".	1¼ in. x .035 in. bands. Locate at Items "G", snug tight around Items "B".
J	3 per pile.	2 in. x .050 in. bands, encircling top five pieces of pipe, equally spaced.
K	2 per pile.	2 in. x .050 in. bands, encircling bottom eight pieces of pipe, suitably spaced.
L	4 per pile.	2 in. x .050 in. bands, encircling entire pile, equally spaced over length of pile.

Suitable end bulkhead, below top of car end, may be used to prevent pipe contacting end of car. Use optional. Pile must be located centrally on car.

See General Rules 4, 5, 9, 10, 14 and 15 for further details.

WROUGHT IRON AND STEEL PIPE OVER 26 IN. IN DIAMETER, 12 FT. LONG OR OVER, WITH 2 IN. X .050 IN. HIGH TENSION BANDS—FLAT OR GONDOLA CARS

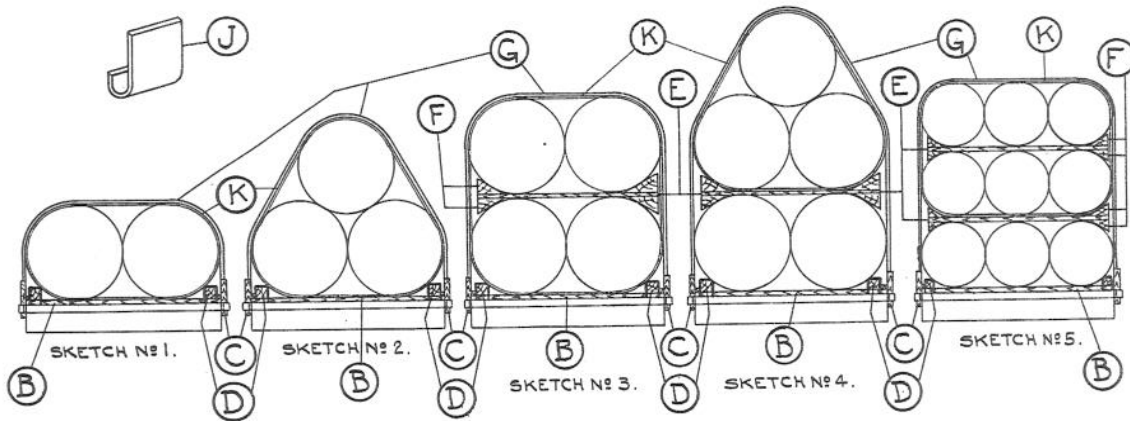
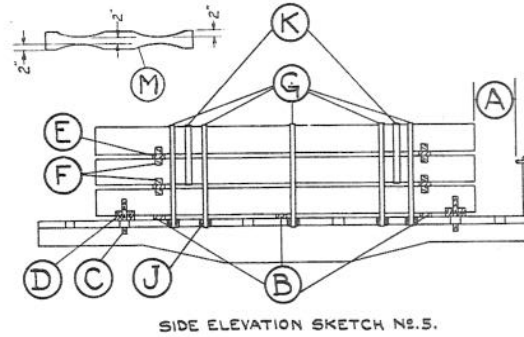
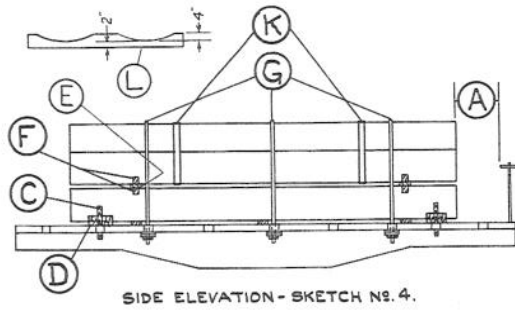

Item	No. of Pcs.	Description
A		Brake wheel clearance. See Fig. 2.
B	3 per pile.	2 in. x 4 in., hardwood, length equal to width of car, suitably spaced. Not required when Items "L" are used.
C	Pile 20 ft. long or less, 2 pr. per pile. Pile over 20 ft. long, 3 pr. per pile.	Stakes, extending 9 in. above floor. Not required for gondola cars.
D	Pile 20 ft. long or less, 4 per pile. Pile over 20 ft. long, 6 per pile.	8 in. x 8 in. x 16 in., hardwood, for pipe to 56 in. in diameter, 8 in. x 10 in. x 16 in., hardwood, for pipe over 56 in. in diameter. Cut top edge to provide a 2 in. bearing against pipe. Nail to floor with 60-D nails. Not required for gondola cars when pipe completely fills inside width of car. Space between Items "C" and "D" must be filled in with suitable blocking nailed to floor.
E	Pile 20 ft. long or less, 2 per pile between ea. successive layer. Pile over 20 ft. long, 3 per pile between ea. successive layer.	2 in. x 6 in., hardwood, long enough to apply Items "F", but short enough to clear bands. Not required beneath top layer when top layer is nested. Not required when Items "M" are used.

WROUGHT IRON AND STEEL PIPE OVER 26 IN. IN DIAMETER, 12 FT. LONG OR OVER, WITH 2 IN. X .050 IN. HIGH TENSION BANDS—FLAT OR GONDOLA CARS

Item	No. of Pcs.	Description
F	4 ea. Item "E".	4 in. x 6 in., hardwood, wedge shaped, nailed to Items "E" with five 16-D nails in each, three in tapered face and two in outside face. Not required when Items "M" are used.
G	Sketches 1 and 2. Pile 20 ft. long or less, 2 per pile. Pile over 20 ft. long, 3 per pile. Sketches 3, 4 and 5. Pile 20 ft. long or less, 3 per pile. Pile over 20 ft. long, add one additional band for ea. 10 ft. or less in length over 20 ft.	Bands. Pass over top of load and attach to opposite stake pockets or car sides.
H		VACANT.
J	2 ea. Item "G".	4 in. wide, $\frac{1}{2}$ in. radius, metal filler of suitable design and strong enough to maintain this radius.
K	Sketch 1. Pile 20 ft. long or less, 1 per pile. Pile over 20 ft. long, 2 per pile. Sketches 2 and 3. Pile 20 ft. long or less, 2 per pile. Pile over 20 ft. long, 3 per pile. Sketches 4 and 5. Pile 20 ft. long or less, 2 per pile. Pile over 20 ft. long, add 1 additional for ea. 10 ft. or less in length over 20 ft.	Bands encircling entire pile. When one band is used, apply at center. When two are used, apply one about one-fourth length of pile from each end. Not required for gondola cars. Bands encircling entire pile. When two are used, apply one about one-fourth length of pile from each end, third band, when used, to be located at center of pile. Bands, encircling top portion of pile above bottom row, suitably spaced.
L	3 per pile.	6 in. x 6 in., hardwood, cradle blocks on floor, cut to fit contour of pipe. Not required when Items "B" are used.
M	Pile 20 ft. long or less, 2 per pile between ea. successive layer. Pile over 20 ft. long, 3 per pile between ea. successive layer.	6 in. x 6 in., hardwood, cradle blocks—intermediate, cut to fit contour of pipe. Not required beneath top layer when top layer is nested. Not required when Items "E" and "F" are used.

$\frac{3}{4}$ in. dia. rods may be substituted for bands, Items "G", in like number. When rods pass through floor, use 4 in. x 4 in. x 18 in., hardwood, or $\frac{1}{2}$ in. x 4 in. x 18 in. plate under floor. When rods pass through stake pockets, use $\frac{1}{2}$ in. x 4 in. x 10 in. plate under stake pockets.

When more than one-half the diameter of top layer of pipe is below top of car sides, Items "G" are not required.

Longitudinal welds on pipe must not contact bands.

See General Rules 4, 5, 9, 10, 14 and 15 for further details.

WROUGHT IRON AND STEEL PIPE 34 IN. OR 36 IN. IN DIAMETER, MAXIMUM THICKNESS .500 IN., WITH 2 IN. X .050 IN. HIGH TENSION BANDS—FLAT CARS

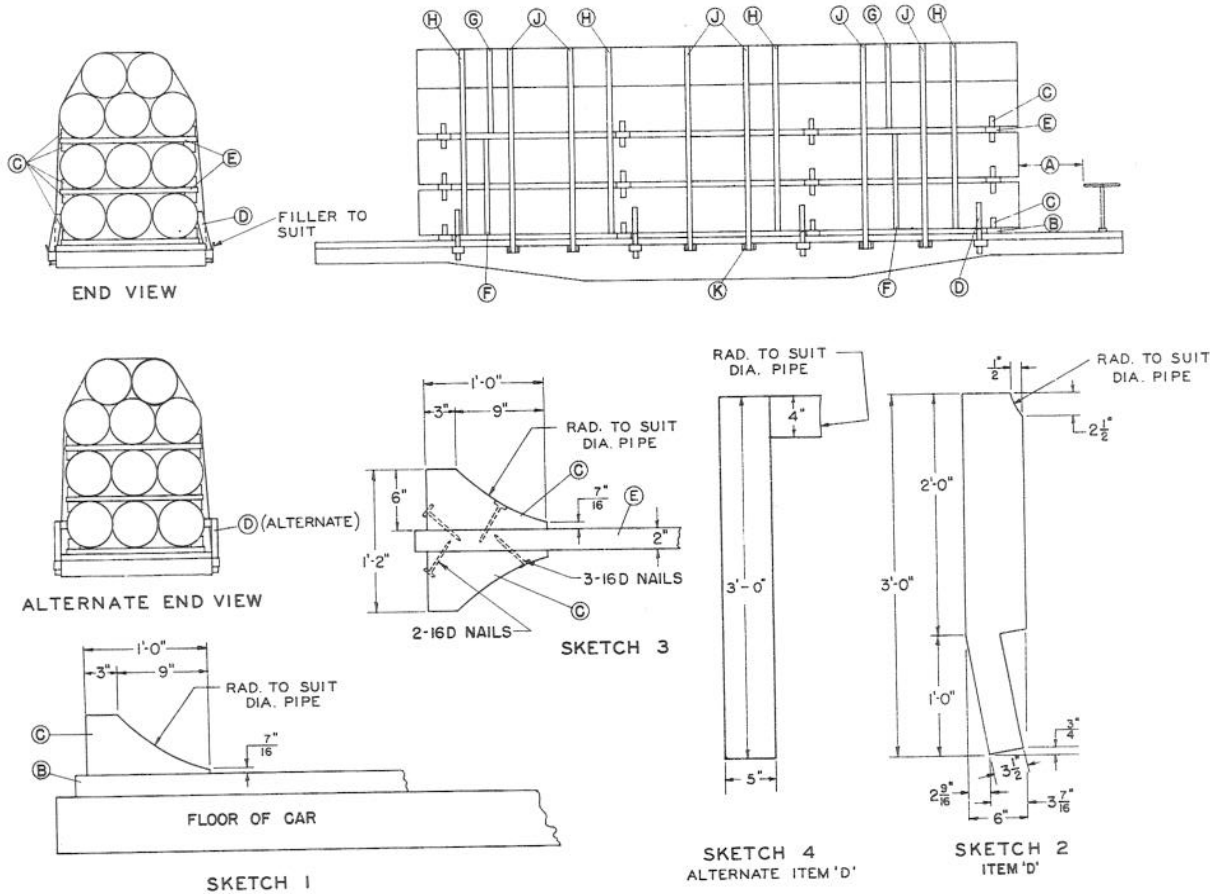

Item	No. of Pcs.	Description
A		Brake wheel clearance. See Fig. 2.
B	4 per pile.	2 in. x 6 in. (rough) hardwood, length equal to width of car, suitably spaced.
C	2 ea. Item "B", also 4 ea. Item "E".	4 in. x 6 in. x 12 in., wood chock blocks, cut to fit contour of pipe. Locate against pipe and nail to Item "B" with five 16-D nails, 3 through contour surface and Item "B" and 2 through vertical surface and Item "E".
D	4 pr. per pile.	Stakes 4 in. x 6 in. x 36 in. hardwood, Sketch 2 or Sketch 4. Inside face cut to fit contour of pipe and suitably spaced.
E	4 between first and second layer and 4 between second and third layer.	2 in. x 6 in. (rough) hardwood, length equal to width of load, with four 4 in. x 6 in. x 12 in. wood chock blocks (Item "C"). Locate against pipe and nail to Item "E" with five 16-D nails, three through contour surface and Item "E", and two through vertical surface and Item "E". Sketch 3.
F	2 per pile.	2 in. x .050 in. bands, suitably spaced, encircling the two bottom layers.
G	2 per pile.	2 in. x .050 in. bands, suitably spaced, encircling the two top layers.
H	4 per pile.	2 in. x .050 in. bands, suitably spaced, encircling entire pile.
J	6 per pile.	2 in. x .050 in. bands, suitably spaced. Pass over top of load and secure to opposite stake pockets.
K	2 ea. Item "J".	Metal filler 4 in. wide and of sufficient thickness to maintain 1/2 in. radius and secured to prevent displacement must be used to protect bands at all stake pockets.

Pipe must be loaded centrally on car and longitudinal welds on pipe must not contact bands.
See General Rules 4, 5, 9, 10, 14 and 15 for further details.

WROUGHT IRON AND STEEL PIPE, 60 INCHES AND OVER IN DIAMETER—GONDOLA CARS

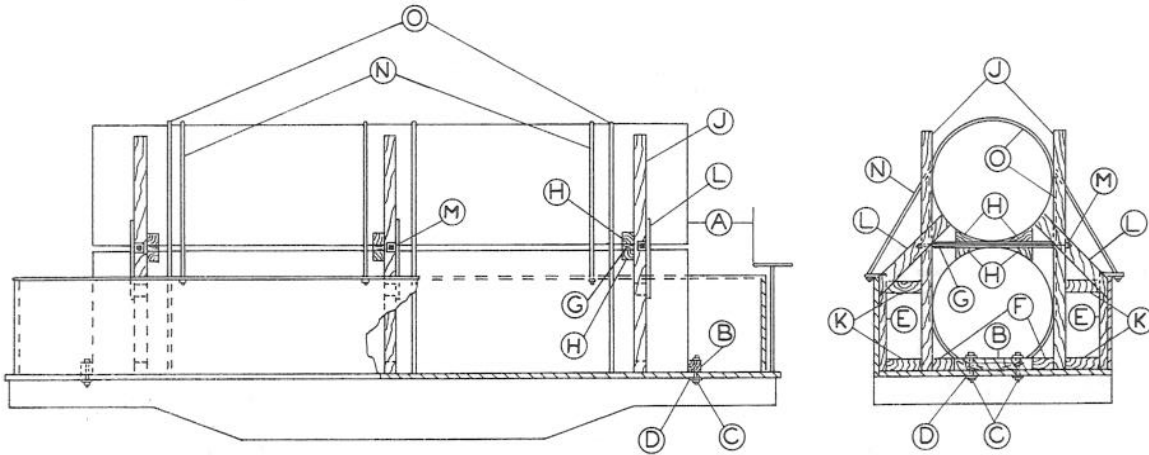

Item	No. of Pcs.	Description
A		Brake wheel clearance. See Fig. 2.
B	2 ea. pile.	6 in. x 6 in., hardwood, length to suit. Cut to fit contour of pipe.
C	2 ea. Item "B".	$\frac{5}{8}$ in. diameter, bolts with washers.
D	1 ea. Item "C".	4 in. x 4 in. x 18 in., hardwood, or $\frac{1}{2}$ in. x 4 in. x 18 in. plates.
E	2 ea. pr. Items "J".	2 in. x 6 in., hardwood, height of car sides. Nail with 20-D nails.
F	2 ea. pr. Items "J".	6 in. x 6 in., hardwood, cut to fit contour of pipe, long enough to extend from pipe to stakes. Nail with 60-D nails.
G	1 ea. pr. Items "J".	2 in. x 6 in., hardwood, length to suit.
H	4 ea. Item "G".	6 in. x 6 in., hardwood, wedge shaped. Nail to Item "G" with 30-D nails.
J	12 ft. long or less, 2 pr. Over 12 ft. long to 24 ft. long, 3 pr. Add 1 for ea. additional 8 ft. or less.	6 in. x 6 in., hardwood.
K	2 ea. Item "J".	6 in. x 6 in., hardwood, length to suit. Toe-nail bottom pieces to floor, Items "E" and "J". Toe-nail top pieces to Items "E" and "J". Use 30-D nails.
L	2 ea. pr. Items "J".	2 in. x 6 in., hardwood, length to suit. Nail to Items "E", "J" and "K" with 30-D nails.
M	1 ea. pr. Items "J".	$\frac{5}{8}$ in. diameter rod, length to suit with $\frac{1}{4}$ in. x 4 in. x 4 in. plate washers.
N	12 ft. long or less, 2. Over 12 ft. long to 24 ft. long, 3. Add 1 for ea. additional 8 ft. or less.	$\frac{3}{4}$ in. diameter rods or bands of equal strength, with threaded ends. When rods pass through floor, use cleats or plates, per Item "D". Substitute, if desired, at each location, one 2 in. x .050 in. high tension band.
O	12 ft. long or less, 2. Over 12 ft. long to 24 ft. long, 3. Add 1 for ea. additional 8 ft. or less.	2 in. x .050 in. high tension bands. Substitute, if desired, at each location, one $\frac{3}{4}$ in. diameter rod, bent to fit contour of pipe on top and bear against sides of pipe and pass through floor and Item "D".

Pipe less than 12 ft. long must be loaded below top of car sides.

Small diameter pipe must not be loaded inside larger diameter pipe, except when loaded below top of car sides.

See General Rules 4, 5, 9, 10, 14 and 15 for further details.

WROUGHT IRON AND STEEL PIPE OF LARGE DIAMETER—GONDOLA CARS

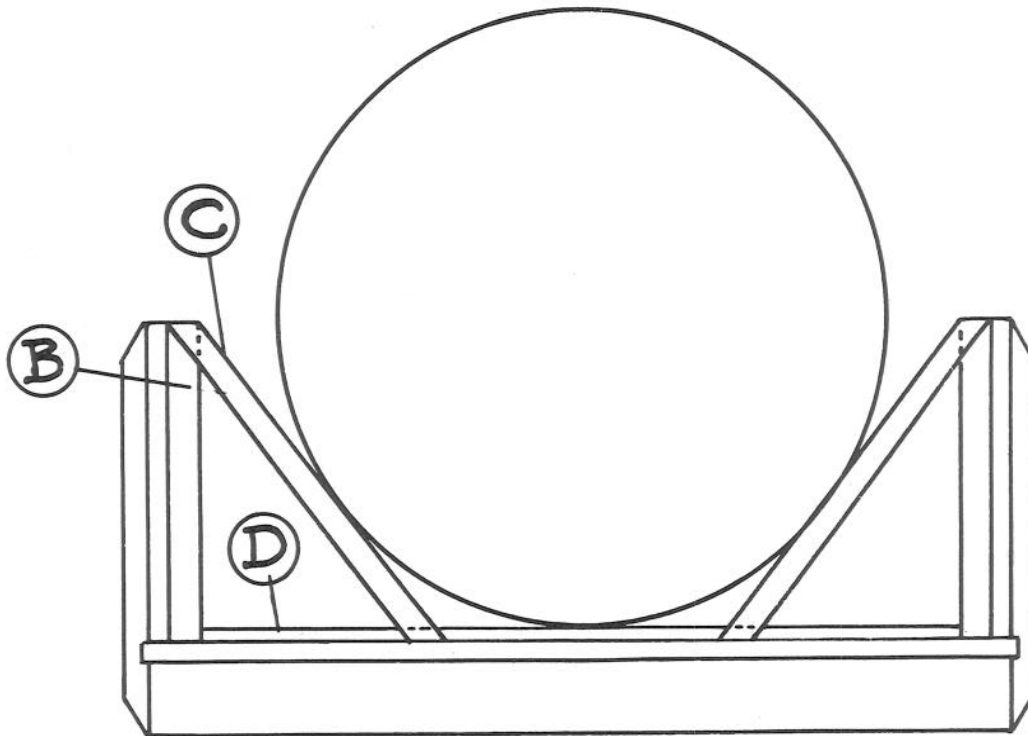

Item	No. of Pcs.	Description
A		Brake wheel clearance. See Fig. 2.
B	3 pr. per pile.	Stakes, hardwood, to top of car sides, equally spaced, nailed or bolted to car side.
C	1 ea. Item "B".	2 in. x 6 in., length to suit, nailed to Items "B" and "D".
D	1 at ea. pr. Items "B".	1 in. x 4 in., length equal to width of car.

Small diameter pipe must not be loaded inside larger diameter pipe, except when loaded below top of car sides.

See General Rules 4, 5, 9, 10, 14 and 15 for further details.

WRAPPED WROUGHT IRON AND STEEL PIPE, WITH HIGH TENSION BANDS—GONDOLA CARS

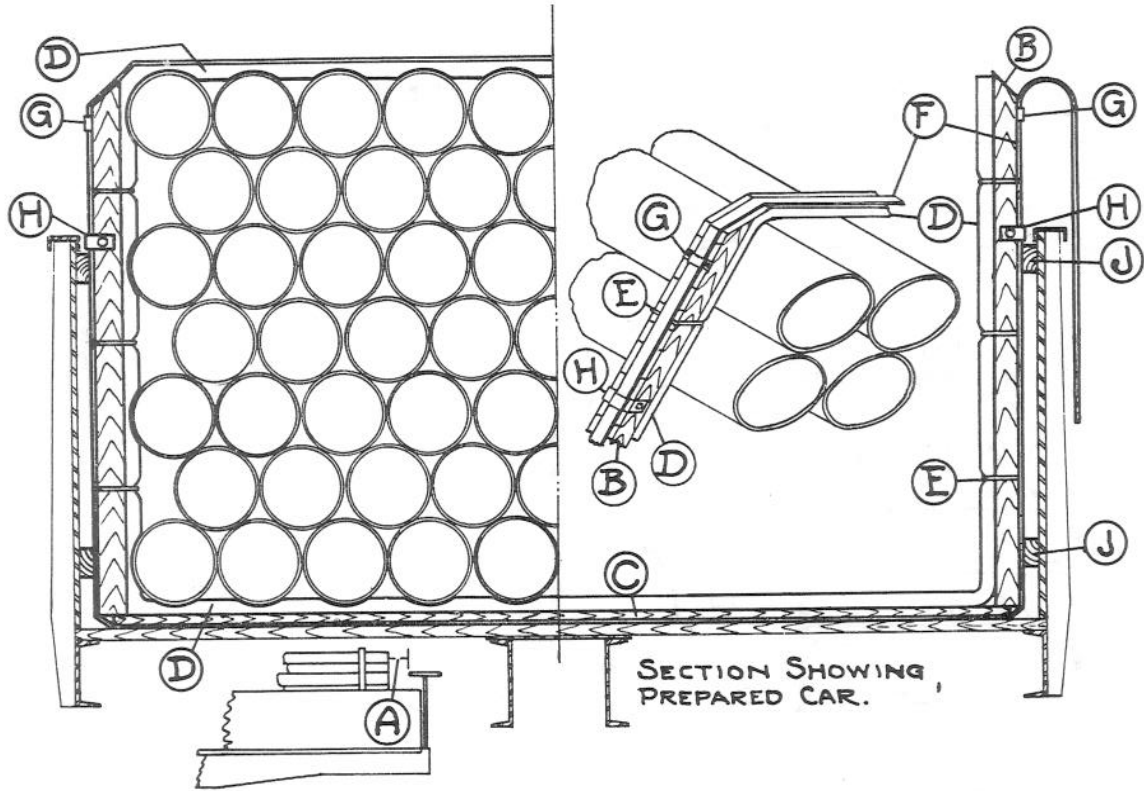

Item	No. of Pcs.	Description
A		Brake wheel clearance. See Fig. 2.
B	Pile 25 ft. long or less, 3 pr. Pile over 25 ft. long, 4 pr. Add 1 pr. when load exceeds 3 ft. above car sides.	Stakes, hardwood, extending from top of Item "C" to top of load. Place not more than 5 ft. from ends of pipe, and equally space intermediate stakes. Half of thickness to project beyond ends of Item "C".
C	1 ea. Item "B".	2 in. x 6 in., about 3 in. shorter than inside width of car.
D	1 ea. Item "B" and "C" and across top of load at ea. pr. Items "B".	Excelsior padding entirely enclosed in heavy wrapping paper.
E	4 ea. Item "B".	Wire to secure Item "D" to Item "B".
F	1 ea. Item "B".	2 in. x .050 in. bands.
G	1 near top ea. Item "B".	Metal plate to hold them "F" in place on Item "B", but permit Item "F" free vertical movement to allow drawing same tight.
H	1 ea. Item "B" located to contact top angle of car when load shifts to side of car.	Metal strap over Item "F" and nailed to sides of Item "B".
J	2 ea. Item "B".	Suitable block, one near top and one near bottom between car side and Item "B" to hold same in place until load has been secured with Item "F". Remove after loading is completed.

Pipe 8 ft. long or less must be loaded below top of car sides. Small diameter pipe must not be loaded inside larger diameter pipe, except when loaded below top of car sides.

See General Rules 4, 5, 9, 10 and 15 for further details.

COATED WROUGHT IRON AND STEEL PIPE, WITH HIGH TENSION BANDS—FLAT OR GONDOLA CARS

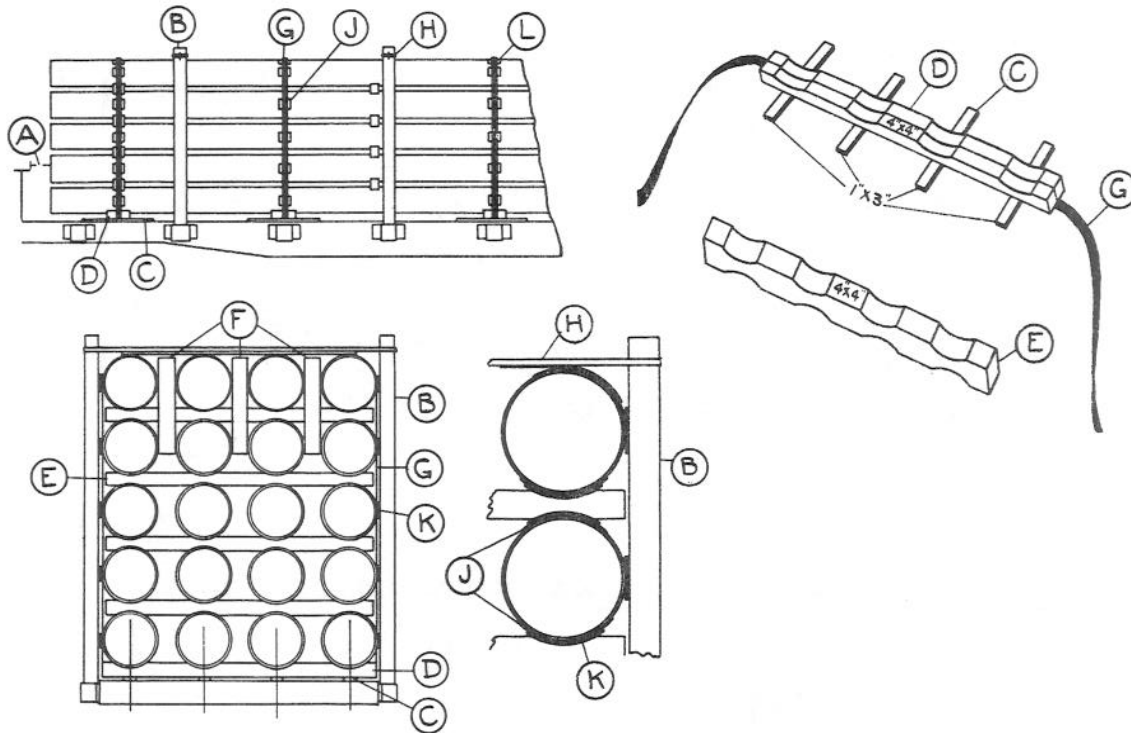

Item	No. of Pcs.	Description
A		Brake wheel clearance. See Fig. 2.
B	Pile 40 ft. long or less, 3 pr. Pile over 40 ft. long, 4 pr.	4 in. x 5 in., hardwood stakes, extending above load to permit application of Item "H".
C	4 ea. Item "D".	1 in. x 3 in. x 18 in., hardwood, nailed to Items "D".
D	Pile 40 ft. long or less, 4 pr. Pile over 40 ft. long, 5 pr.	4 in. x 4 in., hardwood, length equal to width of load, cut out on top 1 in. deep to fit contour of pipe, with rounded corners at bottom to prevent sharp bends in bands.
E	Pile 40 ft. long or less, 3. Pile over 40 ft. long, 4.	4 in. x 4 in., hardwood, length equal to width of load, between each layer of pipe. Cut out on top and bottom 1 in. deep to fit contour of pipe.
F	As required.	Dimensions to suit, locate as shown, apply before Items "G" are tensioned. Secure to prevent displacement.
G	Pile 40 ft. long or less, 4. Pile over 40 ft. long, 5.	2 in. x .050 in. bands, around entire load passing underneath Items "D" and on top of Item "C".
H	1 ea. pr. Items "B".	1 1/4 in. x .035 in. band, secured to Items "B" with staples.
J	As required.	No. 20 ga. dimensions to suit, between pipe and Items "K" at each bearing piece, secured to prevent displacement.
K	As required.	Padding between Items "J" and bearing piece, also between each pipe and Items "B".
L	4 ea. Item "G".	No. 20 ga., dimensions to suit. Pipe must be equally spaced as shown.

Pipe 8 ft. long or less must not be loaded on flat cars or above top of gondola car sides. Small diameter pipe must not be loaded inside larger diameter pipe, except when loaded below top of car sides.

See General Rules 4, 5, 9, 10, 14 and 15 for further details.

Sec. 2—Fig. 139

CAST IRON PIPE, 12 IN. AND LESS IN DIAMETER, 12 FT. LONG OR OVER—GONDOLA CARS

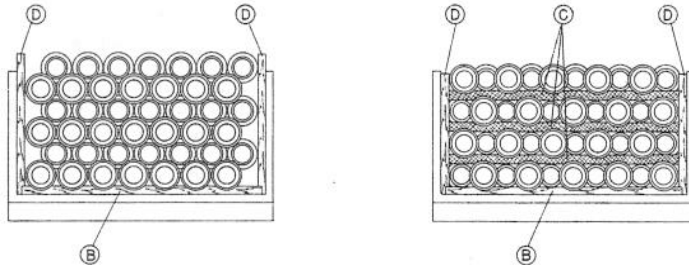
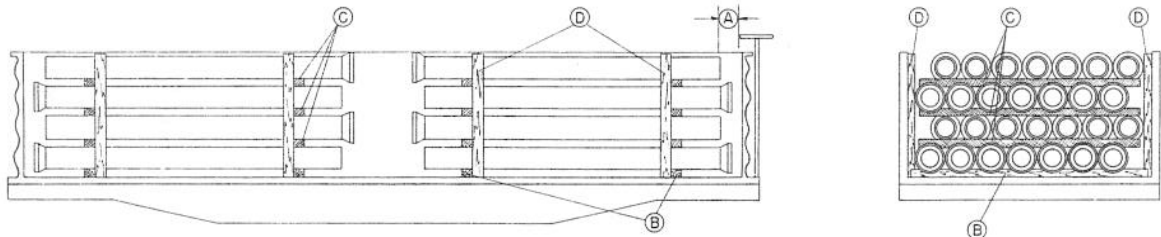

ALTERNATE METHODS

Item	No. of Pcs.	Description
A		Brake wheel clearance. See Fig. 2.
B	2 per pile.	Wood strips, high enough to keep flange or bell from coming in contact with floor, rivet heads, etc., length 2 in. less than width of car. Locate about $\frac{1}{5}$ the distance from each end of pile.
C	2 per pile.	Wood strips, excelsior or similar material, between successive layers, when necessary.
D	4 per pile.	Wood strips, when necessary, to keep pipe from coming in contact with sides, gussets, rivets, etc.

Secure pipe extending above car sides with 3 pairs of stakes per pile, 4 in. x 4 in., extending from floor to top of pile. Opposite stakes must be tied together above pipe with 6 strands, No. 11 ga. wire.

When loading two piles per car, place bell ends of top layers toward center of car; when loading three piles per car, place bell ends of top layer of end piles toward center of car. Space between piles should be about 2 ft.

Pipe less than 12 ft. long must be loaded below top of car sides.

See General Rules 4, 5, 9, 10 and 15 for further details.

Sec. 2—Fig. 140

CAST IRON PIPE 14 IN. TO 30 IN. DIAMETER, INCLUSIVE, 12 FT. LONG OR OVER—GONDOLA CARS

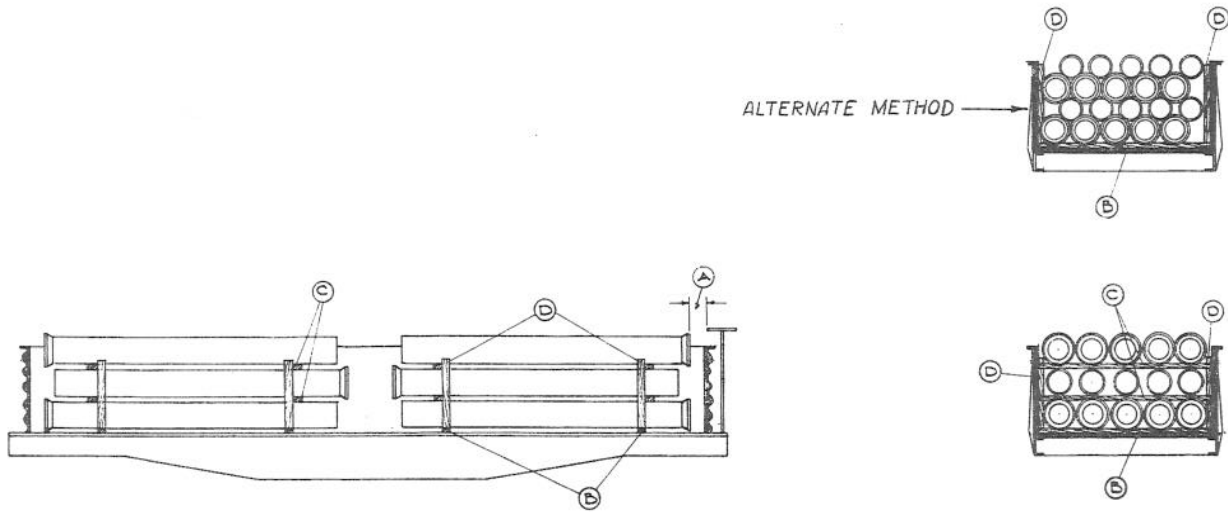

Item	No. of Pcs.	Description
A		Brake wheel clearance. See Fig. 2.
B	2 per pile.	Wood strips, high enough to keep flange or bell from coming in contact with floor, rivet heads, etc., length 2 in. less than width of car. Locate about $\frac{1}{2}$ the distance from each end of pile.
C	2 per pile.	Wood strips, excelsior or similar material, between successive layers, when necessary.
D	4 per pile.	Wood strips, when necessary, to keep pipe from coming in contact with sides, gussets, rivets, etc.

Pipe extending more than $\frac{1}{2}$ its diameter above car sides must be secured with 3 pairs of stakes per pile. Opposite stakes must be tied together above pipe with 6 strands of No. 11 ga. wire.

Pipe less than 12 ft. long must be loaded below top of car sides.

See General Rules 4, 5, 9, 10 and 15 for further details.

Sec. 2—Fig. 141

CAST IRON PIPE 14 IN. AND LESS IN DIAMETER WITH 2 IN. X .050 IN. HIGH TENSION BANDS—FLAT CARS

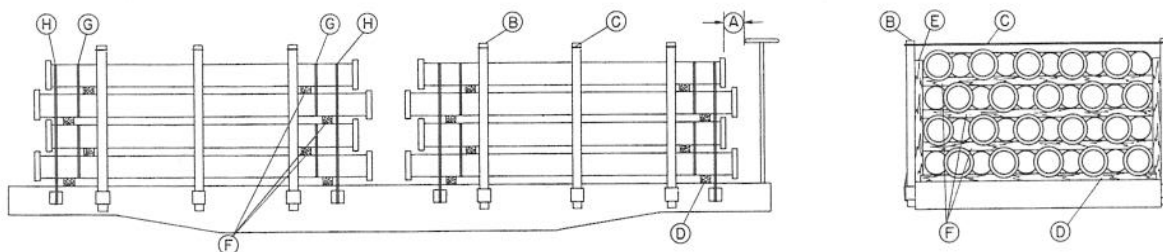

Item	No. of Pcs.	Description
A		Brake wheel clearance. See Fig. 2.
B	3 pr. per pile.	Stakes, hardwood, long enough to extend above top of load.
C	3 per pile.	8 strands, No. 11 ga. wire, twisted taut.
D	2 per pile.	Floor bearing pieces thick enough to keep bell ends off floor and load level, when necessary, to prevent damage to pipe.
E	1 ea. Item "B".	Width of, and nailed to stake, thickness to suit. Use when pipe does not completely fill space between stake.
F		Suitable separators to keep load level.
G	2 per bundle.	2 in. x .050 in. high tension bands encircling each bundle.
H	2 ea. two bundles.	2 in. x .050 in. high tension bands passed across top of load and secured to stake pockets with seals approximately 18 in. above pocket.

See General Rules 10 and 15 for further details.

Sec. 2—Fig. 142

CAST IRON PIPE, 16 IN. DIAMETER AND OVER—FLAT CARS

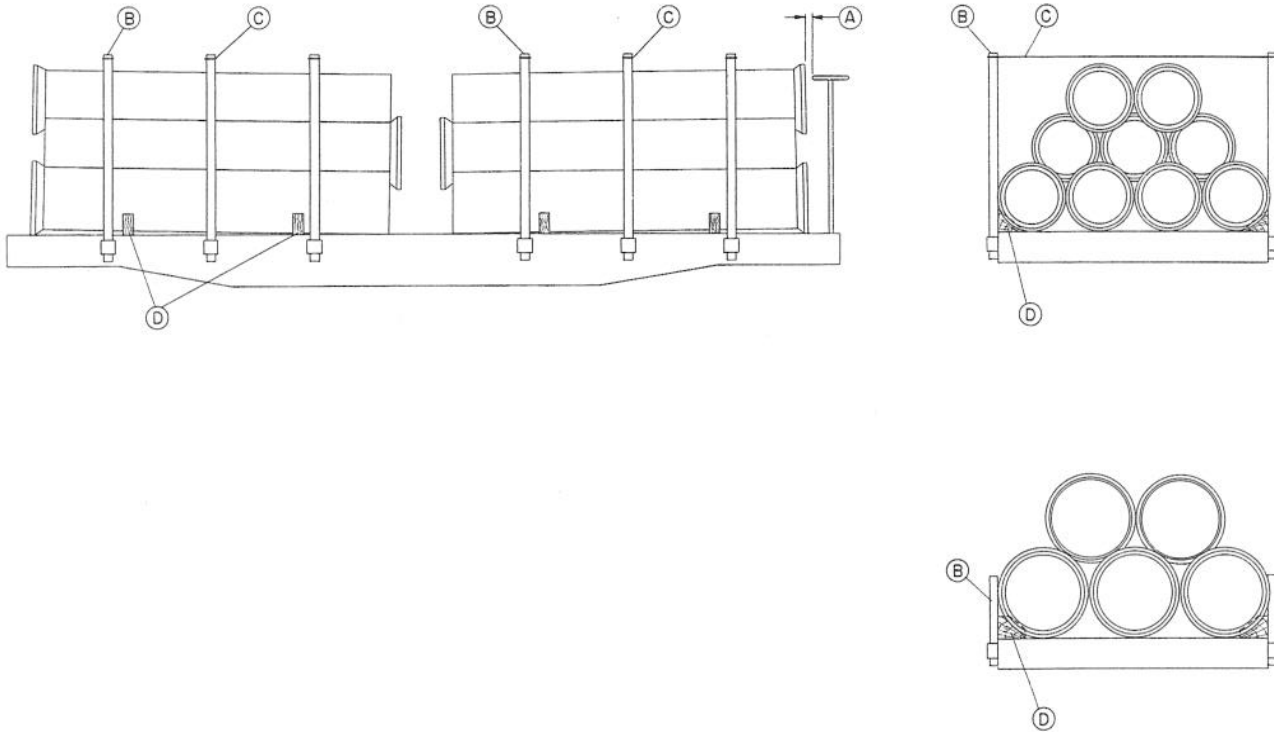

Item	No. of Pcs.	Description
A		Brake wheel clearance. See Fig. 2.
B	3 pr. per pile.	Stakes, hardwood, long enough to extend 15 in. above floor when pipe is loaded two high and long enough to extend above top of pile when loaded 3 or 4 high.
C	1 ea. pr. Items "B".	8 strands, No. 11 ga. wire, twisted taut. Not required on pipe loaded two high.
D	2 ea., outside pipe, ea. pile.	4 in. x 5 in., hardwood, wedge shaped, equally spaced, nailed to floor with 40-D nails.
E		Suitable dunnage between pipe, when necessary, to prevent damage to pipe.

Place bell ends of pipe in bottom layer of end piles toward end of car.

See General Rules 10 and 15 for further details.

Sec. 2—Fig. 143

CAST IRON PIPE LESS THAN 24 INCHES IN DIAMETER, 12 FEET LONG OR OVER (NOT EXCEEDING TWO LAYERS ABOVE TOP OF CAR SIDES), WITH 2 IN. X .050 IN. HIGH TENSION BANDS—GONDOLA CARS

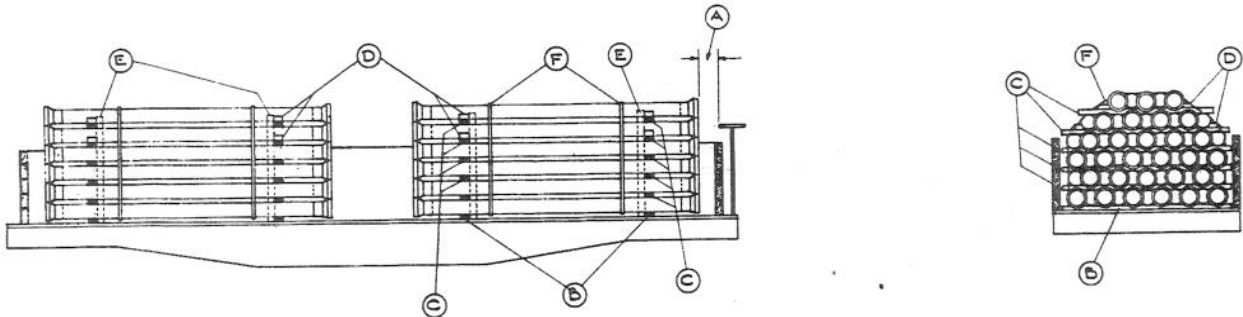

Item	No. of Pcs.	Description
A		Brake wheel clearance. See Fig. 2.
B	2 per pile.	Wood strips, 3 in. wide, high enough to keep flange or bell from coming in contact with floor, rivet heads, etc., length 2 in. less than width of car. Locate about $\frac{1}{5}$ the distance from each end of pile.
C	2	3 in. x 4 in., between successive layers. Locate directly above Items "B".
D	2 ea. Items "B" and "C".	4 in. x 6 in., wedge shaped, nailed to Items "B" and "C" with five 16-D nails in each, three in tapered face and two in outside face. Not required below top of car side when pipe completely covers full width of car.
E	2 per pile.	3 in. x 3 in., long enough to extend from floor to 6 in. above center line of top layer of pipe, secured to Items "C". Use optional.
F	2 per pile.	Bands. Locate about 12 in., from Items "C".

Pipe less than 12 ft. long must be loaded below top of car sides.

Length of car permitting bell ends of pipe should be about 16 inches in from plain ends of pipe, and ends of pile about 18 inches from ends of car.

If desired, suitable cushioning material may be applied between piles and between piles and ends of car.

See General Rules 4, 5, 9, 14 and 15 for further details.

Sec. 2—Fig. 144

CAST IRON PIPE 24 IN. TO 54 IN. IN DIAMETER, INC., 12 FT. LONG OR OVER, WITH 2 IN. X .050 IN. HIGH TENSION BANDS—GONDOLA CARS

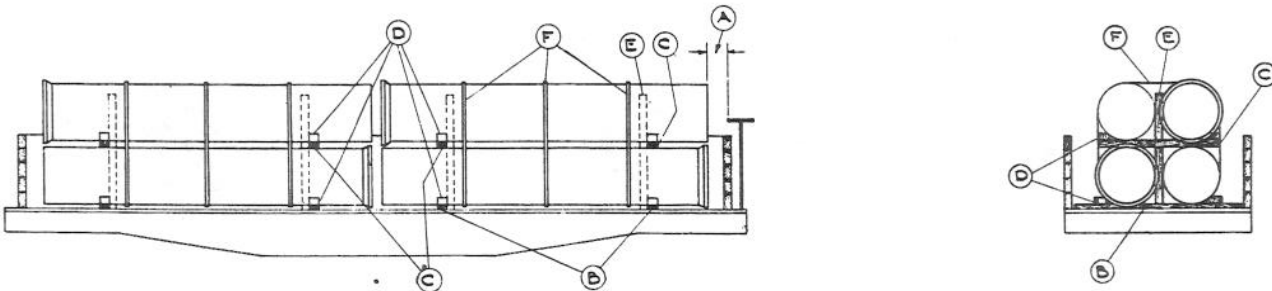

Item	No. of Pcs.	Description
A		Brake wheel clearance. See Fig. 2.
B	2 per pile.	Wood strips, 3 in. wide, high enough to keep flange or bell from coming in contact with floor, rivet heads, etc., length 2 in. less than width of car. Locate about $\frac{1}{2}$ the distance from each end of pile.
C	2	2 in. x 3 in., or of sufficient thickness to clear bell ends (height must not exceed width), between successive layers. Locate directly above Items "B".
D	2 ea. Items "B" and "C".	4 in. x 6 in., wedge shaped, nailed to Items "B" and "C" with five 16-D nails in each, three in tapered face and two in outside face.
E	2 per pile.	3 in. x 3 in., long enough to extend from floor to 6 in. above center line of top layer of pipe, secured to Items "C".
F	3 per pile.	Bands. Locate end bands about 12 in. from Items "C" and third band, when used, at center of pile. When pipe 30 in. or less in diameter extends $\frac{1}{2}$ or less its diameter above top of car sides, and when pipe 36 in., or more, in diameter extends $\frac{1}{4}$ or less its diameter above top of car sides, the center band may be omitted.

Pipe less than 12 ft. long must be loaded below top of car sides.

See General Rules 4, 9, 14 and 15 for further details.

Sec. 2—Fig. 145

CAST IRON PIPE 36 IN. TO 48 IN. DIAMETER, INCLUSIVE, 12 FT. LONG OR OVER—GONDOLA CARS

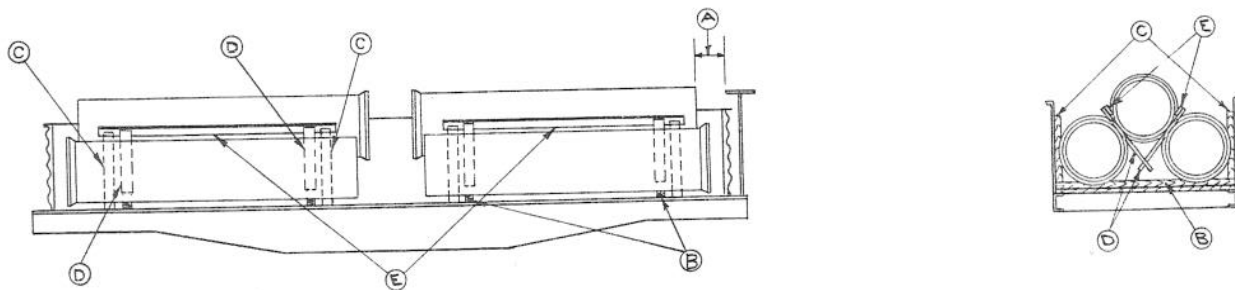

Item	No. of Pcs.	Description
A		Brake wheel clearance. See Fig. 2.
B	2 per pile.	4 in. x 8 in. or of sufficient height to clear bell end from floor of car. Length 2 in. less than width of car.
C	4 per pile.	4 in. x 4 in. height equal to diameter of pipe.
D	4 per pile.	2 in. x 6 in., length to suit.
E	2 per pile.	2 in. x 6 in., length to suit. Nailed to Items "D".

Rope, excelsior or similar material may be used in place of Items "D" and "E".

See General Rules 4, 5, 9 and 14 for further details.

Sec. 2—Fig. 146

CAST IRON PIPE 36 IN. TO 48 IN. DIAMETER, INCLUSIVE, 12 FT. LONG OR OVER—FLAT CARS

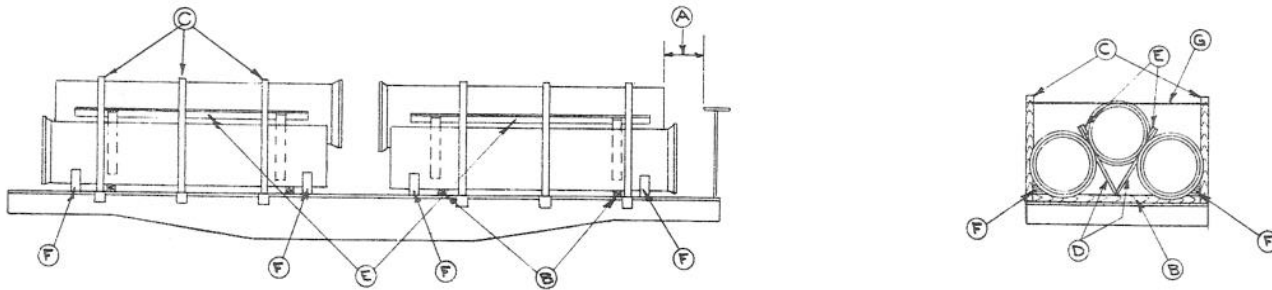

Item	No. of Pcs.	Description
A		Brake wheel clearance. See Fig. 2.
B	2 per pile.	4 in. x 8 in. or of sufficient height to clear bell end from floor of car. Length 2 in. less than width of car.
C	3 pairs per pile.	Stakes—hardwood, long enough to extend above top of pile.
D	4 per pile.	2 in. x 6 in., length to suit.
E	2 per pile.	2 in. x 6 in., length to suit. Nailed to Items "D".
F	4 per pile.	Wedge blocks 4 in. wide, placed against pipe and securely nailed to car floor.
G	1 each pair Items "C".	6 strand No. 9 gauge wire. Substitute if desired one $1\frac{1}{4}$ in. x .035 in. high tension band.

Rope, excelsior or similar material may be used in place of Items "D" and "E".

See General Rules 4, 5, 9, 10, 14 and 15 for further details.

CAST IRON FLANGED OR MECHANICAL JOINT PIPE, 12 FT. LONG OR OVER—GONDOLA CARS

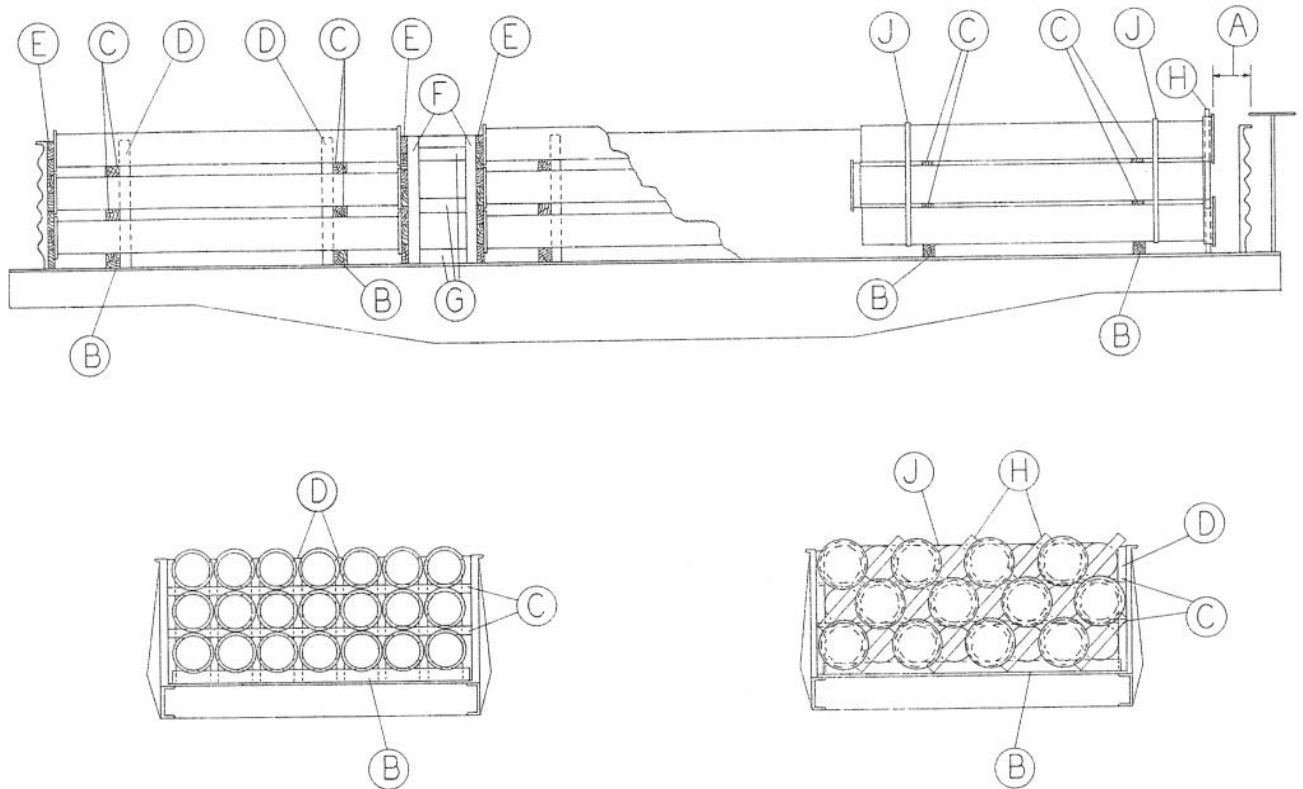

Item	No. of Pcs.	Description
A		Brake wheel clearance. See Fig. 2.
B	2 per pile.	Wood strips, high enough to keep flanges from coming in contact with floor, rivet heads, etc. Width to be greater than height. Length 2 in. less than width of car.
C	2	Wood strips, between successive layers of pipe, thick enough to keep flanges from coming in contact with each other. Width to be greater than height. Locate directly above Items "B".
D	As required.	Wood strips, between each pipe and between pipe and car sides. Width, thickness and length to suit.
E	As required.	2 in. thick, width of car, extending to top of pile.
F	6 ea. bulkhead.	4 in. x 4 in., length to suit.
G	9 ea. bulkhead.	4 in. x 4 in., length to suit, nailed to Items "F".
H	As required.	Wood strips, width, thickness and length to suit. Apply at one end of pile, as shown, to prevent straight ends contacting flanged ends of pipe. Not required for pipe over 12 in. in diameter.
J	2 per pile.	2 in. x .050 in. high tension bands. Not required when Items "D" are used.

For layers extending more than two-thirds their height above top of car sides, 4 in. x 6 in., wedge blocks, must be used against pipe on each end of each Item "C".

When unit method of loading is used, Items "D", "E", "F" and "G" may be omitted, except where ends of pile are loaded less than 18 in. from end of car or with less than 18 in. between piles.

End gates, built up of 2 in. x 6 in. uprights and cross pieces may be substituted for Items "E", "F" and "G" when ends of pile are less than 18 in. from end of car, or when less than 18 in. between piles.

Rope, excelsior or similar material may be used in place of Items "C" and "D".

See General Rules 4, 5, 9, 14 and 15 for further details.

Sec. 2—Fig. 148

GALVANIZED CORRUGATED PIPE, 30 INCHES OR LESS IN DIAMETER, WITH HIGH TENSION BANDS—
GONDOLA CARS

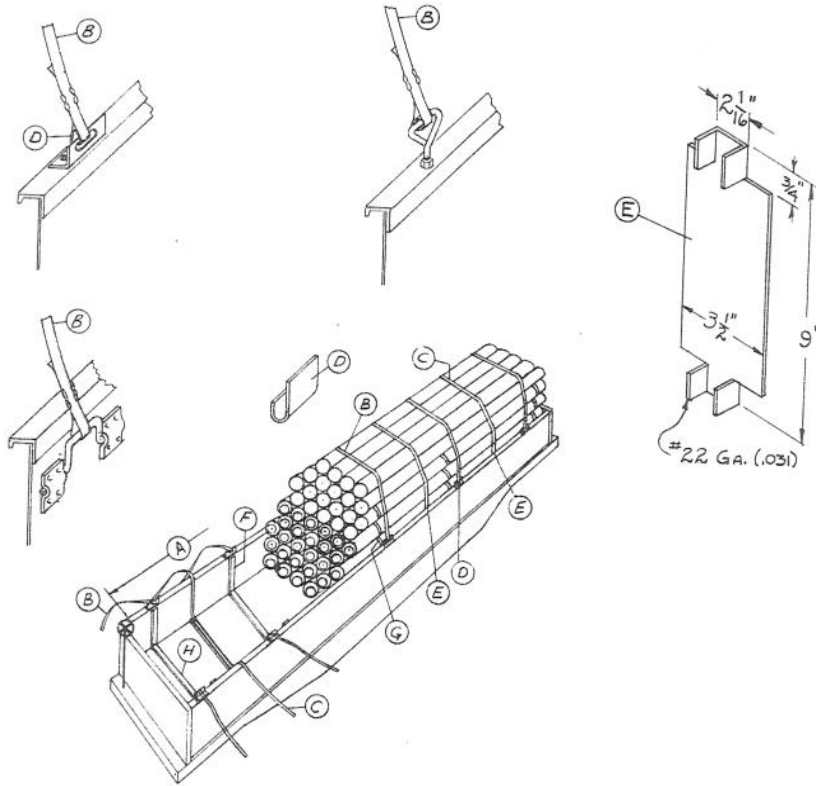

Item	No. of Pcs.	Description
A		Brake wheel clearance. See Fig. 2.
B	Pile 30 ft. long or less, 2; pile over 30 ft. long, 3.	2 in. x .050 in. bands, attached to stake pockets, anchor bolts or slotted angle. Not required when load is not more than 2 ft. above car sides.
C	Pile 30 ft. long or less, 2; pile over 30 ft., 3.	2 in. x .050 in. bands, encircling entire pile, equally spaced. Add 1 additional band for each band specified when Items "B" are not used.
D	1 ea. stake pocket.	4 in. wide, 1/2 in. radius, metal filler of suitable design and strong enough to maintain this radius.
E	2 ea. Item "B" and "C".	Use when bands may contact metal at top of car sides.
F	4 ea. pile.	4 in. wide, thick enough to prevent pipe from contacting car sides, etc. Use optional.
G	3 ea. layer.	3/4 in. x .035 in. bands, encircling entire layer when outside pipe in layer are directly above or slightly overhanging pipe below.
H	3 per pile.	4 in. wide, thick enough to prevent pipe contacting floor, rivet heads, etc., length equal to width of load.

Place all bands in corrugations of pipe.

Pipe less than 10 ft. long must be loaded below top of car sides. Small diameter pipe may be loaded inside larger diameter pipe.

Where small diameter spiral corrugated pipe is loaded inside larger diameter pipe above top of car sides, the inner and outer pipe must be wired together to prevent shifting.

Coated or treated pipe may be separated by wood, excelsior or similar material, when necessary.

See General Rules 4, 5, 9, 10 and 15 for further details.

Sec. 2—Fig. 149

GALVANIZED CORRUGATED PIPE, LESS THAN 36 INCHES IN DIAMETER—GONDOLA CARS

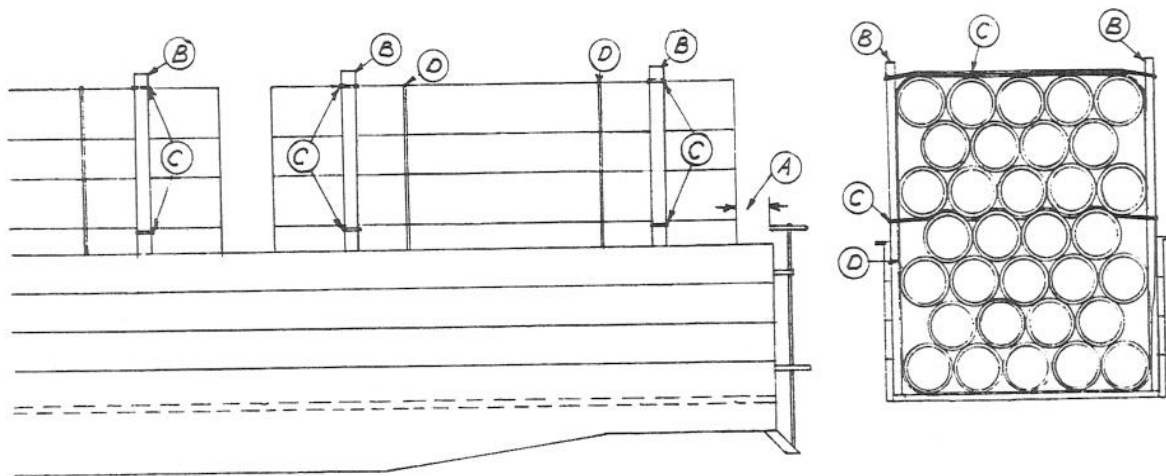

Item	No. of Pcs.	Description
A		Brake wheel clearance. See Fig. 2.
B	2 pr. per pile.	Stakes, hardwood.
C	2 ea. pr. Items "B".	6 strands, No. 11 gage wire, at top of load and above first row of pipe extending wholly or partially above car side.
D	Pile 30 ft. long or less 2 per pile. Add 1 for ea. additional 10 ft. or less in length.	6 strands, No. 11 gage wire, around entire pile, about 4 ft. from each end of pipe. Substitute, if desired, at each location, 2 — No. 8 gage high tension wires or 1 — 1¼ in. x .035 in. high tension band.

Place all wires or bands in corrugations of pipe.

Pipe less than 10 ft. long must be loaded below top of car sides. Small diameter pipe may be loaded inside larger diameter pipe.

Where small diameter spiral corrugated pipe is loaded inside larger diameter pipe above top of car sides, the inner and outer pipe must be wired together to prevent shifting.

Coated or treated pipe may be separated by wood, excelsior or similar material, when necessary.

See General Rules 4, 5, 9, 10 and 15 for further details.

GALVANIZED CORRUGATED PIPE—LESS THAN 36 INCHES IN DIAMETER—PYRAMIDAL FORM—HIGH TENSION BANDS—GONDOLA CARS

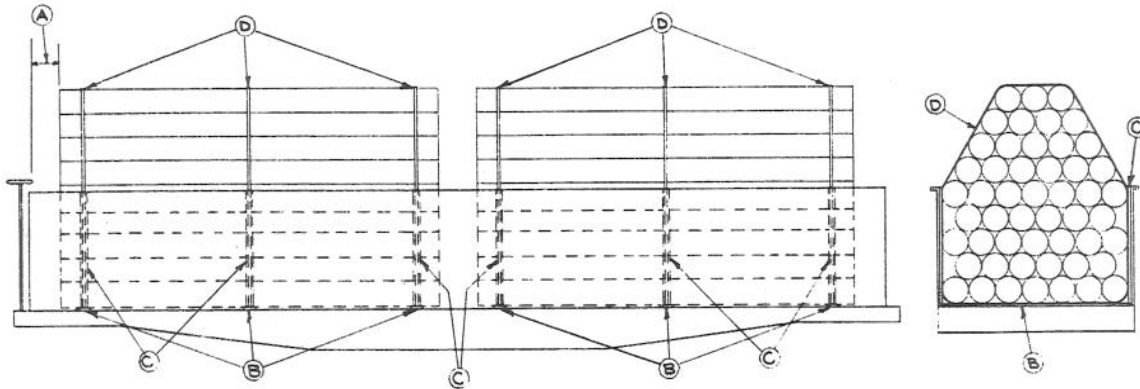

Item	No. of Pcs.	Description
A		Brake wheel clearance. See Fig. 2.
B	3 per pile.	1 in. x 4 in. wood. Length 2 in. less than width of car.
C	6 per pile.	1 in. x 4 in. wood. Length equal to height of car side. Use optional.
D	Pile 16 ft. long or less, 3 per pile. 1 additional for ea. 8 ft. or fraction thereof in excess of 16 ft.	1¼ in. x .035 bands, around entire pile, equally spaced.

At least one-half diameter of pipe in first row below pyramid must be below car side.

Place all bands in corrugations of pipe.

Pipe less than 10 ft. long must be loaded below top of car sides. Small diameter pipe may be loaded inside larger diameter pipe.

Where small diameter spiral corrugated pipe is loaded inside larger diameter pipe above top of car sides, the inner and outer pipe must be wired together to prevent shifting.

Coated or treated pipe may be separated by wood, excelsior or similar material, when necessary.

When ends of pile are loaded against end of car, wood strips may be placed between end of car and ends of pipe.

See General Rules 4, 5, 9, 10 and 15 for further details.

Sec. 2—Fig. 151

GALVANIZED CORRUGATED PIPE, LESS THAN 36 INCHES IN DIAMETER—FLAT CARS

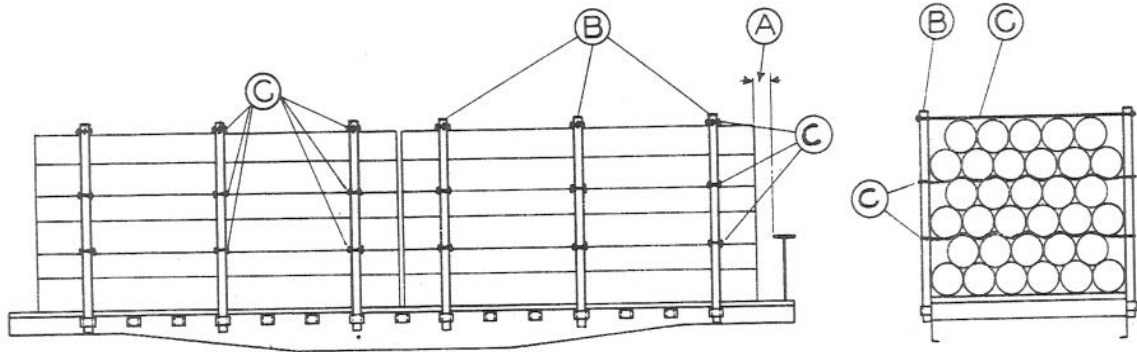

Item	No. of Pcs.	Description
A		Brake wheel clearance. See Fig. 2.
B	File 30 ft. long or less, 3 pr.; pile over 30 ft. long, 4 pr.	Stakes, hardwood, extending above load to permit application of Item "C" as shown.
C	Ea. pr. Items "B" according to height of load.	6 strands, No. 11 gage wire, not more than 30 in. apart, and across top of load, twisted taut. Substitute, if desired, at each location, 2—No. 8 gage high tension wires or 1—1¼ in. x .035 in. high tension band.

Place all wires in corrugations of pipe.

Pipe less than 10 ft. long must not be loaded on flat cars. Small diameter pipe may be loaded inside larger diameter pipe.

Where small diameter spiral corrugated pipe is loaded inside larger diameter pipe above top of car sides, the inner and outer pipe must be wired together to prevent shifting.

Coated or treated pipe may be separated by wood, excelsior or similar material, when necessary.

See General Rules 4, 5, 9, 10 and 15 for further details.

Sec. 2—Fig. 152

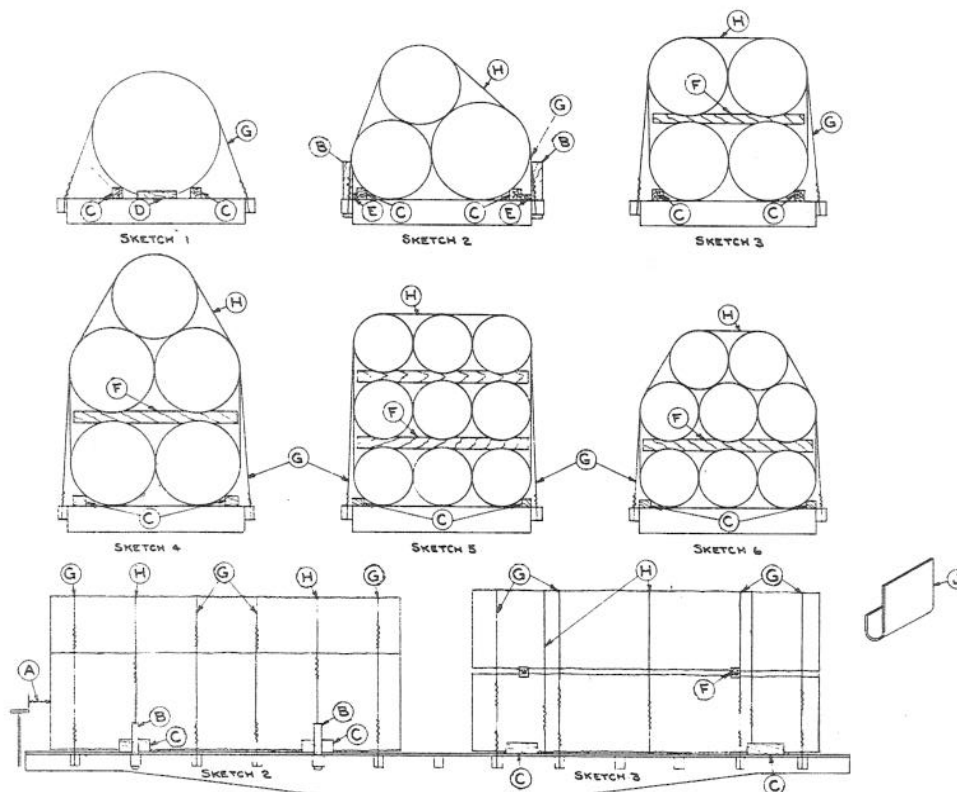
GALVANIZED CORRUGATED PIPE, 36 INCHES OR OVER IN DIAMETER WITH NO. 8 GAGE HIGH TENSION WIRE—
FLAT OR GONDOLA CARS

Item	No. of Pcs.	Description
A		Brake wheel clearance. See Fig. 2.
B	Sketch 2 only. Pile 30 ft. long or less, 2 pr. Pile over 30 ft. long, 3 pr.	4 in. x 5 in., extending 14 in. above floor, or in contact with pipe wider than car. May be used on Sketches 3, 4, 5 and 6.
C	2 ea. side of ea. pile.	4 in. x 4 in. x 12 in. Nail to floor with 40-D nails.
D	Sketch 1 only. 1 ea. end of ea. pipe.	2 in. x 4 in. x 12 in. Nail to floor with 40-D nails. When two or more pipe are loaded end to end, one block between each two pipe will suffice.
E	Sketch 2 only. 1 ea. Item "C".	2 in. x 4 in., long enough to fill space between Items "B" and "C". Nail to floor with 30-D nails. Must be used on Sketches 3, 4, 5 and 6 if Items "B" are used.
F	Sketches 3, 4, 5 and 6 only. Pile 30 ft. long or less, 2. Pile over 30 ft. long, 3.	6 in. x 6 in. hardwood, length to suit. Cut top and bottom to fit contour of pipe. Substitute, if desired, 2 in. x 6 in., hardwood, length to suit, with four 4 in. x 6 in. x 12 in. chock blocks. Two chock blocks to be located at each end of 2 in. x 6 in. spacer, one above and one below, each end of spacer secured with five 16-D nails in each.
G	Sketch 1. 3 per pile 30 ft. long or less. 5 per pile over 30 ft. long. Sketches 2, 3, 4, 5 and 6. 4 per pile 30 ft. long or less. 5 per pile over 30 ft. long.	No. 8 gage wire, attached to stake pocket or top side chord. When 3 are used, place one at center of pile, and one about 2 ft. from ends of pile. When 4 and 5 are used, space evenly throughout pile.
H	Sketches 2, 3, 4, 5 and 6. 2 per pile 30 ft. long or less. 4 per pile over 30 ft. long. Sketch 3. 3 per pile 30 ft. long or less. 4 per pile over 30 ft. long.	No. 8 gage wire encircling pile.
J	2 ea. Item "G".	Fillers at stake pockets to prevent cutting of wires in transit.

Items "B", "D" and "E" not required for gondola cars.
Place all wires in corrugations of pipe.
Pipe less than 10 ft. long must not be loaded on flat cars, or above top of gondola car sides. Small diameter pipe may be loaded inside larger diameter pipe.
Where small diameter spiral corrugated pipe is loaded inside larger diameter pipe above top of car sides, the inner and outer pipe must be wired together to prevent shifting.
Coated or treated pipe may be separated by wood, excelsior or similar material, when necessary.
See General Rules 4, 5, 9, 10 and 15 for further details.